



US010074806B2

(12) **United States Patent**  
**Adamovich et al.**

(10) **Patent No.:** **US 10,074,806 B2**  
(45) **Date of Patent:** **Sep. 11, 2018**

(54) **ORGANIC ELECTROLUMINESCENT MATERIALS AND DEVICES**

*403/14* (2013.01); *C07D 471/04* (2013.01);  
*C07D 487/04* (2013.01); *C07D 491/048*  
(2013.01); *C07D 495/04* (2013.01); *C07F*  
*15/0033* (2013.01); *H01L 51/0052* (2013.01);  
*H01L 51/0067* (2013.01); *H01L 51/0071*  
(2013.01); *H01L 51/0072* (2013.01); *H01L*  
*51/0085* (2013.01); *H01L 51/5012* (2013.01);  
*H01L 51/5016* (2013.01); *H01L 51/56*  
(2013.01)

(71) Applicant: **Universal Display Corporation**,  
Ewing, NJ (US)

(72) Inventors: **Vadim Adamovich**, Yardley, PA (US);  
**Hitoshi Yamamoto**, Pennington, NJ  
(US); **Ting-Chih Wang**, Lawrenceville,  
NJ (US); **Michael S. Weaver**,  
Princeton, NJ (US); **Chuanjun Xia**,  
Lawrenceville, NJ (US); **Bert Alleyne**,  
Newtown, PA (US); **Pierre-Luc T.**  
**Boudreault**, Pennington, NJ (US);  
**Alexey Borisovich Dyatkin**, Ambler,  
PA (US); **Scott Joseph**, Ewing, NJ (US)

(58) **Field of Classification Search**

CPC ..... C07F 15/0033; C07D 403/04  
See application file for complete search history.

(73) Assignee: **Universal Display Corporation**,  
Ewing, NJ (US)

(\* ) Notice: Subject to any disclaimer, the term of this  
patent is extended or adjusted under 35  
U.S.C. 154(b) by 1120 days.

(21) Appl. No.: **14/253,505**

(22) Filed: **Apr. 15, 2014**

(65) **Prior Publication Data**

US 2015/0053939 A1 Feb. 26, 2015

**Related U.S. Application Data**

(60) Provisional application No. 61/940,603, filed on Feb.  
17, 2014, provisional application No. 61/920,544,  
filed on Dec. 24, 2013, provisional application No.  
61/894,160, filed on Oct. 22, 2013, provisional  
application No. 61/874,444, filed on Sep. 6, 2013,  
provisional application No. 61/867,858, filed on Aug.  
20, 2013.

(51) **Int. Cl.**

*H01L 51/00* (2006.01)  
*C07F 15/00* (2006.01)  
*C07D 403/04* (2006.01)  
*H01L 51/50* (2006.01)  
*H01L 51/56* (2006.01)  
*C07D 403/10* (2006.01)  
*C07D 471/04* (2006.01)  
*C07D 215/06* (2006.01)  
*C07D 401/04* (2006.01)  
*C07D 403/14* (2006.01)  
*C07D 487/04* (2006.01)  
*C07D 491/048* (2006.01)  
*C07D 495/04* (2006.01)  
*C07D 213/06* (2006.01)  
*C07D 213/22* (2006.01)  
*C07D 213/26* (2006.01)

(52) **U.S. Cl.**

CPC ..... *H01L 51/0054* (2013.01); *C07D 213/06*  
(2013.01); *C07D 213/22* (2013.01); *C07D*  
*213/26* (2013.01); *C07D 215/06* (2013.01);  
*C07D 401/04* (2013.01); *C07D 403/04*  
(2013.01); *C07D 403/10* (2013.01); *C07D*

(56) **References Cited**

**U.S. PATENT DOCUMENTS**

4,769,292 A 9/1988 Tang et al.  
5,061,569 A 10/1991 VanSlyke et al.  
5,247,190 A 9/1993 Friend et al.  
5,703,436 A 12/1997 Forrest et al.  
5,707,745 A 1/1998 Forrest et al.  
5,834,893 A 11/1998 Bulovic et al.  
5,844,363 A 12/1998 Gu et al.  
5,981,092 A 11/1999 Arai et al.  
6,013,982 A 1/2000 Thompson et al.  
6,087,196 A 7/2000 Sturm et al.  
6,091,195 A 7/2000 Forrest et al.  
6,097,147 A 8/2000 Baldo et al.  
6,294,398 B1 9/2001 Kim et al.  
6,303,238 B1 10/2001 Thompson et al.  
6,337,102 B1 1/2002 Forrest et al.  
6,468,819 B1 10/2002 Kim et al.  
6,528,187 B1 3/2003 Okada

(Continued)

**FOREIGN PATENT DOCUMENTS**

CN 101657518 2/2010  
CN 102898477 1/2013

(Continued)

**OTHER PUBLICATIONS**

Adachi, Chihaya et al., "Organic Electroluminescent Device Having  
a Hole Conductor as an Emitting Layer," Appl. Phys. Lett., 55(15):  
1489-1491 (1989).

(Continued)

*Primary Examiner* — Joseph R Kosack

(74) *Attorney, Agent, or Firm* — Duane Morris LLP

(57) **ABSTRACT**

A composition formed of a mixture of two compounds  
having similar thermal evaporation properties that are pre-  
mixed into an evaporation source that can be used to  
co-evaporate the two compounds into an emission layer in  
OLEDs via vacuum thermal evaporation process is dis-  
closed.

**26 Claims, 7 Drawing Sheets**

(56)

## References Cited

## U.S. PATENT DOCUMENTS

6,687,266 B1 2/2004 Ma et al.  
6,835,469 B2 12/2004 Kwong et al.  
6,921,915 B2 7/2005 Takiguchi et al.  
7,087,321 B2 8/2006 Kwong et al.  
7,090,928 B2 8/2006 Thompson et al.  
7,154,114 B2 12/2006 Brooks et al.  
7,250,226 B2 7/2007 Tokito et al.  
7,252,859 B2 8/2007 Ng et al.  
7,279,704 B2 10/2007 Walters et al.  
7,332,232 B2 2/2008 Ma et al.  
7,338,722 B2 3/2008 Thompson et al.  
7,393,599 B2 7/2008 Thompson et al.  
7,396,598 B2 7/2008 Takeuchi et al.  
7,431,968 B1 10/2008 Shtein et al.  
7,445,855 B2 11/2008 Mackenzie et al.  
7,534,505 B2 5/2009 Lin et al.  
9,340,728 B2 5/2016 Ise et al.  
2002/0034656 A1 3/2002 Thompson et al.  
2002/0134984 A1 9/2002 Igarashi  
2002/0158242 A1 10/2002 Son et al.  
2003/0138657 A1 7/2003 Li et al.  
2003/0151042 A1 8/2003 Marks et al.  
2003/0152802 A1 8/2003 Tsuboyama et al.  
2003/0175553 A1 9/2003 Thompson et al.  
2003/0230980 A1 12/2003 Forrest et al.  
2004/0036077 A1 2/2004 Ise  
2004/0137267 A1 7/2004 Igarashi et al.  
2004/0137268 A1 7/2004 Igarashi et al.  
2004/0174116 A1 9/2004 Lu et al.  
2005/0025993 A1 2/2005 Thompson et al.  
2005/0112407 A1 5/2005 Ogasawara et al.  
2005/0238919 A1 10/2005 Ogasawara  
2005/0244673 A1 11/2005 Satoh et al.  
2005/0260441 A1 11/2005 Thompson et al.  
2005/0260449 A1 11/2005 Walters et al.  
2006/0008670 A1 1/2006 Lin et al.  
2006/0202194 A1 9/2006 Jeong et al.  
2006/0240279 A1 10/2006 Adamovich et al.  
2006/0251923 A1 11/2006 Lin et al.  
2006/0263635 A1 11/2006 Ise  
2006/0280965 A1 12/2006 Kwong et al.  
2007/0190359 A1 8/2007 Knowles et al.  
2007/0247061 A1 10/2007 Adamovich et al.  
2007/0249148 A1 10/2007 Werner et al.  
2007/0278938 A1 12/2007 Yabunouchi et al.  
2008/0015355 A1 1/2008 Schafer et al.  
2008/0018221 A1 1/2008 Egen et al.  
2008/0106190 A1 5/2008 Yabunouchi et al.  
2008/0124572 A1 5/2008 Mizuki et al.  
2008/0220265 A1 9/2008 Xia et al.  
2008/0297033 A1 12/2008 Knowles et al.  
2009/0008605 A1 1/2009 Kawamura et al.  
2009/0009065 A1 1/2009 Nishimura et al.  
2009/0017330 A1 1/2009 Iwakuma et al.  
2009/0030202 A1 1/2009 Iwakuma et al.  
2009/0039776 A1 2/2009 Yamada et al.  
2009/0045730 A1 2/2009 Nishimura et al.  
2009/0045731 A1 2/2009 Nishimura et al.  
2009/0101870 A1 4/2009 Pakash et al.  
2009/0108737 A1 4/2009 Kwong et al.  
2009/0115316 A1 5/2009 Zheng et al.  
2009/0165846 A1 7/2009 Johannes et al.  
2009/0167162 A1 7/2009 Lin et al.  
2009/0179554 A1 7/2009 Kuma et al.  
2011/0177641 A1 7/2011 Cheon et al.  
2012/0181511 A1 7/2012 Ma et al.  
2012/0241732 A1 9/2012 Endo et al.  
2012/0319146 A1 12/2012 Adamovich et al.  
2013/0112952 A1 5/2013 Adamovich et al.  
2013/0248849 A1 9/2013 Feldman et al.  
2013/0264561 A1 10/2013 Dobbs et al.  
2014/0054564 A1 2/2014 Kim et al.  
2015/0001471 A1 1/2015 Boudreault et al.

2015/0171341 A1 6/2015 Lee et al.  
2015/0357588 A1 12/2015 Kwong et al.  
2016/0099425 A1 4/2016 Kottas et al.

## FOREIGN PATENT DOCUMENTS

CN 102918134 2/2013  
CN 104250244 12/2014  
EP 0650955 5/1995  
EP 1156536 11/2001  
EP 1725079 11/2006  
EP 2034538 3/2009  
EP 2166592 3/2010  
EP 2461390 6/2012  
JP 200511610 1/2005  
JP 2007123392 5/2007  
JP 2007254297 10/2007  
JP 2008074939 4/2008  
JP 2011-091366 5/2011  
JP 2012056880 3/2012  
JP 2012-195140 10/2012  
JP 2012216801 11/2012  
WO 1999/053724 10/1999  
WO 2001039234 5/2001  
WO 2002002714 1/2002  
WO 200215645 2/2002  
WO 2003040257 5/2003  
WO 2003060956 7/2003  
WO 2004/070787 8/2004  
WO 2004093207 10/2004  
WO 2004107822 12/2004  
WO 2005014551 2/2005  
WO 2005019373 3/2005  
WO 2005030900 4/2005  
WO 2005089025 9/2005  
WO 2005123873 12/2005  
WO 2006009024 1/2006  
WO 2006056418 6/2006  
WO 2006072002 7/2006  
WO 2006082742 8/2006  
WO 2006098120 9/2006  
WO 2006100298 9/2006  
WO 2006103874 10/2006  
WO 2006114966 11/2006  
WO 2006132173 12/2006  
WO 2007002683 1/2007  
WO 2007004380 1/2007  
WO 2007063754 6/2007  
WO 2007063796 6/2007  
WO 2008056746 5/2008  
WO 2008101842 8/2008  
WO 2008132085 11/2008  
WO 2009000673 12/2008  
WO 2009003898 1/2009  
WO 2009008311 1/2009  
WO 2009018009 2/2009  
WO 2009/030981 3/2009  
WO 2009050290 4/2009  
WO 2009021126 5/2009  
WO 2009062578 5/2009  
WO 2009063833 5/2009  
WO 2009066778 5/2009  
WO 2009066779 5/2009  
WO 2009086028 7/2009  
WO 2009100991 8/2009  
WO 2010107244 9/2010  
WO 2011013843 2/2011  
WO 2011081423 7/2011  
WO 2011136755 11/2011  
WO 2012005363 1/2012  
WO 2012015274 2/2012  
WO 2012023947 2/2012  
WO 2012064499 5/2012  
WO 2012108879 8/2012  
WO 2012165844 12/2012

(56) **References Cited**

## FOREIGN PATENT DOCUMENTS

WO 2012166101 12/2012

## OTHER PUBLICATIONS

- Adachi, Chihaya et al., "Nearly 100% Internal Phosphorescence Efficiency in an Organic Light Emitting Device," *J. Appl. Phys.*, 90(10): 5048-5051 (2001).
- Adachi, Chihaya et al., "High-Efficiency Red Electrophosphorescence Devices," *Appl. Phys. Lett.*, 78(11):1622-1624 (2001).
- Aonuma, Masaki et al., "Material Design of Hole Transport Materials Capable of Thick-Film Formation in Organic Light Emitting Diodes," *Appl. Phys. Lett.*, 90:183503-1-183503-3.
- Baldo et al., Highly Efficient Phosphorescent Emission from Organic Electroluminescent Devices, *Nature*, vol. 395, 151-154, (1998).
- Baldo et al., Very high-efficiency green organic light-emitting devices based on electrophosphorescence, *Appl. Phys. Lett.*, vol. 75, No. 3, 4-6 (1999).
- Gao, Zhiqiang et al., "Bright-Blue Electroluminescence From a Silyl-Substituted ter-(phenylene-vinylene) derivative," *Appl. Phys. Lett.*, 74(6): 865-867 (1999).
- Guo, Tzung-Fang et al., "Highly Efficient Electrophosphorescent Polymer Light-Emitting Devices," *Organic Electronics*, 115-20 (2000).
- Hamada, Yuji et al., "High Luminance in Organic Electroluminescent Devices with Bis(10-hydroxybenzo[h]quinolinato) beryllium as an Emitter," *Chem. Lett.*, 905-906 (1993).
- Holmes, R.J. et al., "Blue Organic Electrophosphorescence Using Exothermic Host-Guest Energy Transfer," *Appl. Phys. Lett.*, 82(15):2422-2424 (2003).
- Hu, Nan-Xing et al., "Novel High Tg Hole-Transport Molecules Based on Indolo[3,2-b]carbazoles for Organic Light-Emitting Devices," *Synthetic Metals*, 111-112:421-424 (2000).
- Huang, Jinsong et al., "Highly Efficient Red-Emission Polymer Phosphorescent Light-Emitting Diodes Based on Two Novel Tris(1-phenylisoquinolinato-C2,N)iridium(III) Derivates," *Adv. Mater.*, 19:739-743 (2007).
- Huang, Wei-Sheng et al., "Highly Phosphorescent Bis-Cyclometalated Iridium Complexes Containing Benzoimidazole-Based Ligands," *Chem. Mater.*, 16(12):2480-2488 (2004).
- Hung, L.S. et al., "Anode Modification in Organic Light-Emitting Diodes by Low-Frequency Plasma Polymerization of CHF<sub>3</sub>," *Appl. Phys. Lett.*, 78(5):673-675 (2001).
- Ikai, Masamichi and Tokito, Shizuo, "Highly Efficient Phosphorescence From Organic Light-Emitting Devices with an Exciton-Block Layer," *Appl. Phys. Lett.*, 79(2):156-158 (2001).
- Ikeda, Hisao et al., "P-185 Low-Drive-Voltage OLEDs with a Buffer Layer Having Molybdenum Oxide," *SID Symposium Digest*, 37:923-926 (2006).
- Inada, Hiroshi and Shirota, Yasuhiko, "1,3,5-Tris[4-(diphenylamino)phenyl]benzene and its Methylsubstituted Derivatives as a Novel Class of Amorphous Molecular Materials," *J. Mater. Chem.*, 3(3):319-320 (1993).
- Kanno, Hiroshi et al., "Highly Efficient and Stable Red Phosphorescent Organic Light-Emitting Device Using bis[2-(2-benzothiazoyl)phenolato]zinc(II) as host material," *Appl. Phys. Lett.*, 90:123509-1-123509-3 (2007).
- Kido, Junji et al., 1,2,4-Triazole Derivative as an Electron Transport Layer in Organic Electroluminescent Devices, *Jpn. J. Appl. Phys.*, 32:L917-L920 (1993).
- Kuwabara, Yoshiyuki et al., "Thermally Stable Multilayered Organic Electroluminescent Devices Using Novel Starburst Molecules, 4,4',4"-Tri(N-carbazolyl)triphenylamine (TCTA) and 4,4',4"-Tris(3-methylphenylphenyl-amino)triphenylamine (m-MTDATA), as Hole-Transport Materials," *Adv. Mater.*, 6(9):677-679 (1994).
- Kwong, Raymond C. et al., "High Operational Stability of Electrophosphorescent Devices," *Appl. Phys. Lett.*, 81(1):162-164 (2002).
- Lamansky, Sergey et al., "Synthesis and Characterization of Phosphorescent Cyclometalated Iridium Complexes," *Inorg. Chem.*, 40(7):1704-1711 (2001).
- Lee, Chang-Lyoul et al., "Polymer Phosphorescent Light-Emitting Devices Doped with Tris(2-phenylpyridine) Iridium as a Triplet Emitter," *Appl. Phys. Lett.*, 77(15):2280-2282 (2000).
- Lo, Shih-Chun et al., "Blue Phosphorescence from Iridium(III) Complexes at Room Temperature," *Chem. Mater.*, 18 (21):5119-5129 (2006).
- Ma, Yuguang et al., "Triplet Luminescent Dinuclear-Gold(I) Complex-Based Light-Emitting Diodes with Low Turn-On Voltage," *Appl. Phys. Lett.*, 74(10):1361-1363 (1999).
- Mi, Bao-Xiu et al., "Thermally Stable Hole-Transporting Material for Organic Light-Emitting Diode an Isoindole Derivative," *Chem. Mater.*, 15(16):3148-3151 (2003).
- Nishida, Jun-ichi et al., "Preparation, Characterization, and Electroluminescence Characteristics of  $\alpha$ -Diimine-type Platinum(II) Complexes with Perfluorinated Phenyl Groups as Ligands," *Chem. Lett.*, 34(4): 592-593 (2005).
- Niu, Yu-Hua et al., "Highly Efficient Electrophosphorescent Devices with Saturated Red Emission from a Neutral Osmium Complex," *Chem. Mater.*, 17(13):3532-3536 (2005).
- Noda, Tetsuya and Shirota, Yasuhiko, "5,5'-Bis(dimesitylboryl)-2,2'-bithiophene and 5,5"-Bis(dimesitylboryl)-2,2',5',2"-terthiophene as a Novel Family of Electron-Transporting Amorphous Molecular Materials," *J. Am. Chem. Soc.*, 120 (37):9714-9715 (1998).
- Okumoto, Kenji et al., "Green Fluorescent Organic Light-Emitting Device with External Quantum Efficiency of Nearly 10%," *Appl. Phys. Lett.*, 89:063504-1-063504-3 (2006).
- Palilis, Leonidas C., "High Efficiency Molecular Organic Light-Emitting Diodes Based on Silole Derivatives and Their Exciplexes," *Organic Electronics*, 4:113-121 (2003).
- Paulose, Betty Marie Jennifer S. et al., "First Examples of Alkenyl Pyridines as Organic Ligands for Phosphorescent Iridium Complexes," *Adv. Mater.*, 16(22):2003-2007 (2004).
- Ranjan, Sudhir et al., "Realizing Green Phosphorescent Light-Emitting Materials from Rhenium(I) Pyrazolato Diimine Complexes," *Inorg. Chem.*, 42(4):1248-1255 (2003).
- Sakamoto, Youichi et al., "Synthesis, Characterization, and Electron-Transport Property of Perfluorinated Phenylene Dendrimers," *J. Am. Chem. Soc.*, 122(8):1832-1833 (2000).
- Salbeck, J. et al., "Low Molecular Organic Glasses for Blue Electroluminescence," *Synthetic Metals*, 91209-215 (1997).
- Shirota, Yasuhiko et al., "Starburst Molecules Based on p-Electron Systems as Materials for Organic Electroluminescent Devices," *Journal of Luminescence*, 72-74:985-991 (1997).
- Sotoyama, Wataru et al., "Efficient Organic Light-Emitting Diodes with Phosphorescent Platinum Complexes Containing NCN-Coordinating Tridentate Ligand," *Appl. Phys. Lett.*, 86:153505-1-153505-3 (2005).
- Sun, Yiru and Forrest, Stephen R., "High-Efficiency White Organic Light Emitting Devices with Three Separate Phosphorescent Emission Layers," *Appl. Phys. Lett.*, 91:263503-1-263503-3 (2007).
- T. Östergård et al., "Langmuir-Blodgett Light-Emitting Diodes of Poly(3-Hexylthiophene) Electro-Optical Characteristics Related to Structure," *Synthetic Metals*, 87:171-177 (1997).
- Takizawa, Shin-ya et al., "Phosphorescent Iridium Complexes Based on 2-Phenylimidazo[1,2- $\alpha$ ]pyridine Ligands Tuning of Emission Color toward the Blue Region and Application to Polymer Light-Emitting Devices," *Inorg. Chem.*, 46(10):4308-4319 (2007).
- Tang, C.W. and VanSlyke, S.A., "Organic Electroluminescent Diodes," *Appl. Phys. Lett.*, 51(12):913-915 (1987).
- Tung, Yung-Liang et al., "Organic Light-Emitting Diodes Based on Charge-Neutral Ru II Phosphorescent Emitters," *Adv. Mater.*, 17(8):1059-1064 (2005).
- Van Slyke, S. A. et al., "Organic Electroluminescent Devices with Improved Stability," *Appl. Phys. Lett.*, 69 (15):2160-2162 (1996).
- Wang, Y. et al., "Highly Efficient Electroluminescent Materials Based on Fluorinated Organometallic Iridium Compounds," *Appl. Phys. Lett.*, 79(4):449-451 (2001).
- Wong, Keith Man-Chung et al., A Novel Class of Phosphorescent Gold(III) Alkynyl-Based Organic Light-Emitting Devices with Tunable Colour, *Chem. Commun.*, 2906-2908 (2005).

(56)

**References Cited**

## OTHER PUBLICATIONS

Wong, Wai-Yeung, "Multifunctional Iridium Complexes Based on Carbazole Modules as Highly Efficient Electrophosphors," *Angew. Chem. Int. Ed.*, 45:7800-7803 (2006).

Chang, Mei-Ying et al., "High-Brightness White Organic Light-Emitting Diodes Featuring a Single Emission Layer," *Journal of the Electrochemical Society* (2009), 156(1), J1-J5.

Wang, D. et al., "Broad wavelength modulating and design of organic white diode based on lighting by using exciplex emission from mixed acceptors," *Applied Physics Letters* (2006), 89(23), 233511/1-233511/3.

Adamovich, Adam et al., "High-efficiency single dopant white electrophosphorescent light-emitting diodes," *New Journal of Chemistry* (2002), 26(9), 1171-1178.

Coya, Carmen et al., "White emission from a single-component single-layer solution processed OLED," *SPIE* (2009), 7415(Organic Light Emitting Materials and Devices XIII), 74151P/1-74151P/12.

Jou, Jwo-Huei et al., "Efficient, color-stable fluorescent white organic light-emitting diodes with single emission layer by vapor deposition from solvent premixed deposition source," *Applied Physics Letters* (2006), 88(19), 193501/1-193501/3.

Jou, Jwo-Huei et al., "Efficient pure-white organic light-emitting diodes with a solution-processed, binary-host employing single emission layer," *Applied Physics Letters* (2006), 88(14), 141101/1-141101/3.

Yang, J.P. et al., "White light emission from a single layer organic light emitting diode fabricated by spincoating," *Chemical Physics Letters* 325 (2000) 251-256.

Office Action dated Jan. 25, 2017 for corresponding Chinese Patent Application No. 201410412431.9.

EP Search Report dated May 19, 2015 for corresponding EP Patent Application No. 14181083.8.

Notice of Reasons for Rejection dated Jan. 16, 2018 for corresponding JP Application No. 2014-166272.

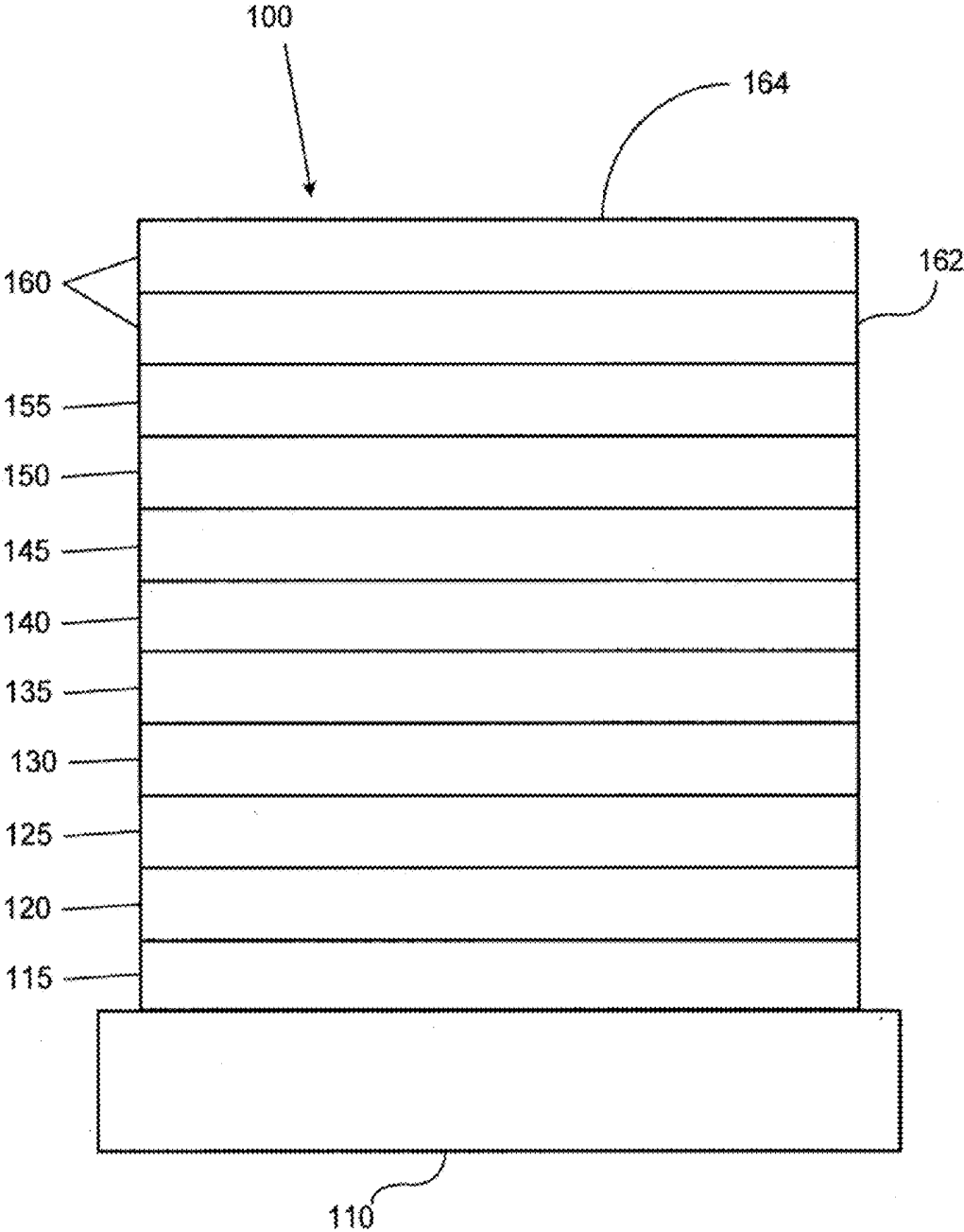

FIG. 1

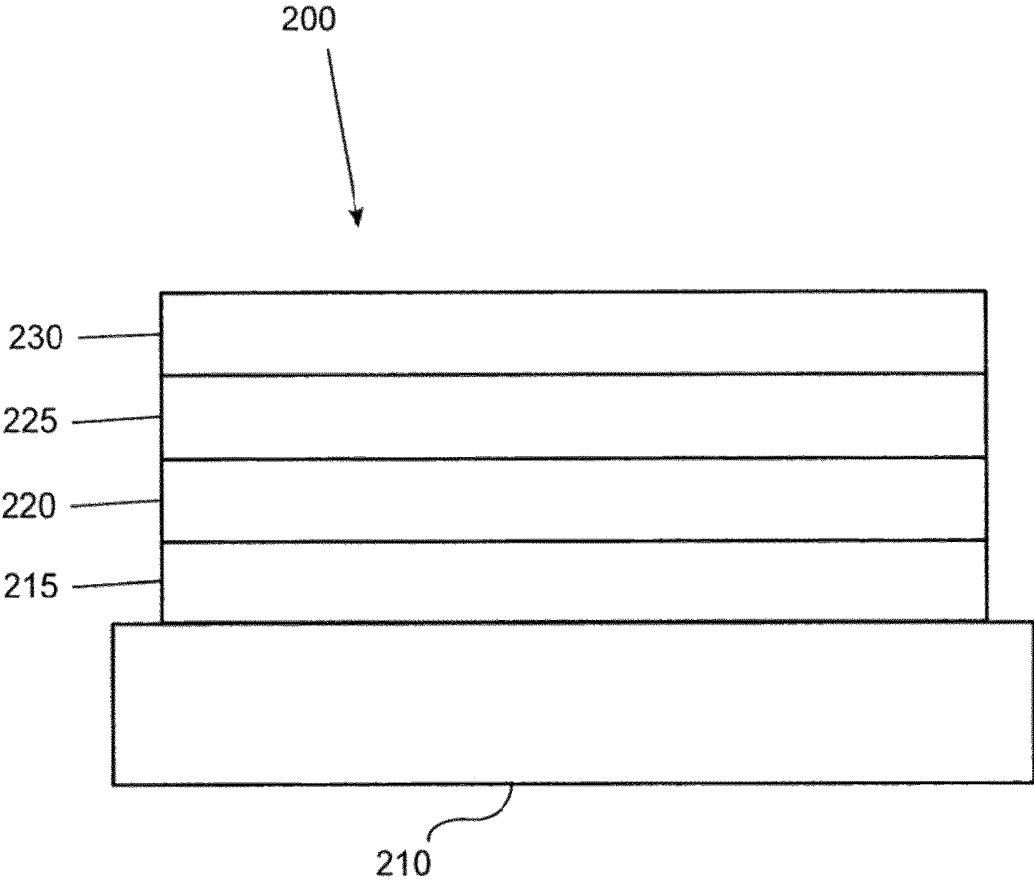

FIG. 2

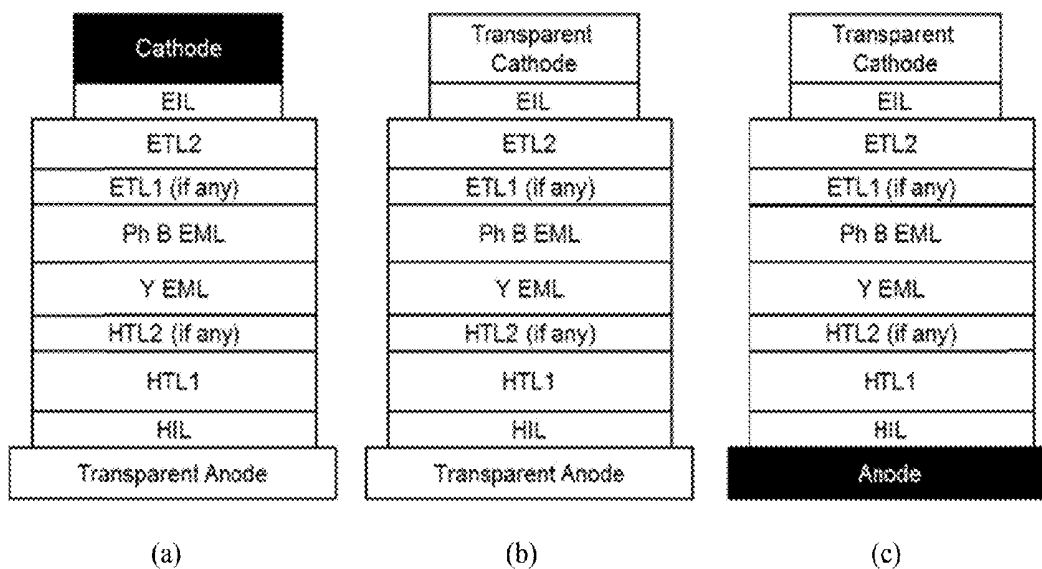

FIG. 3

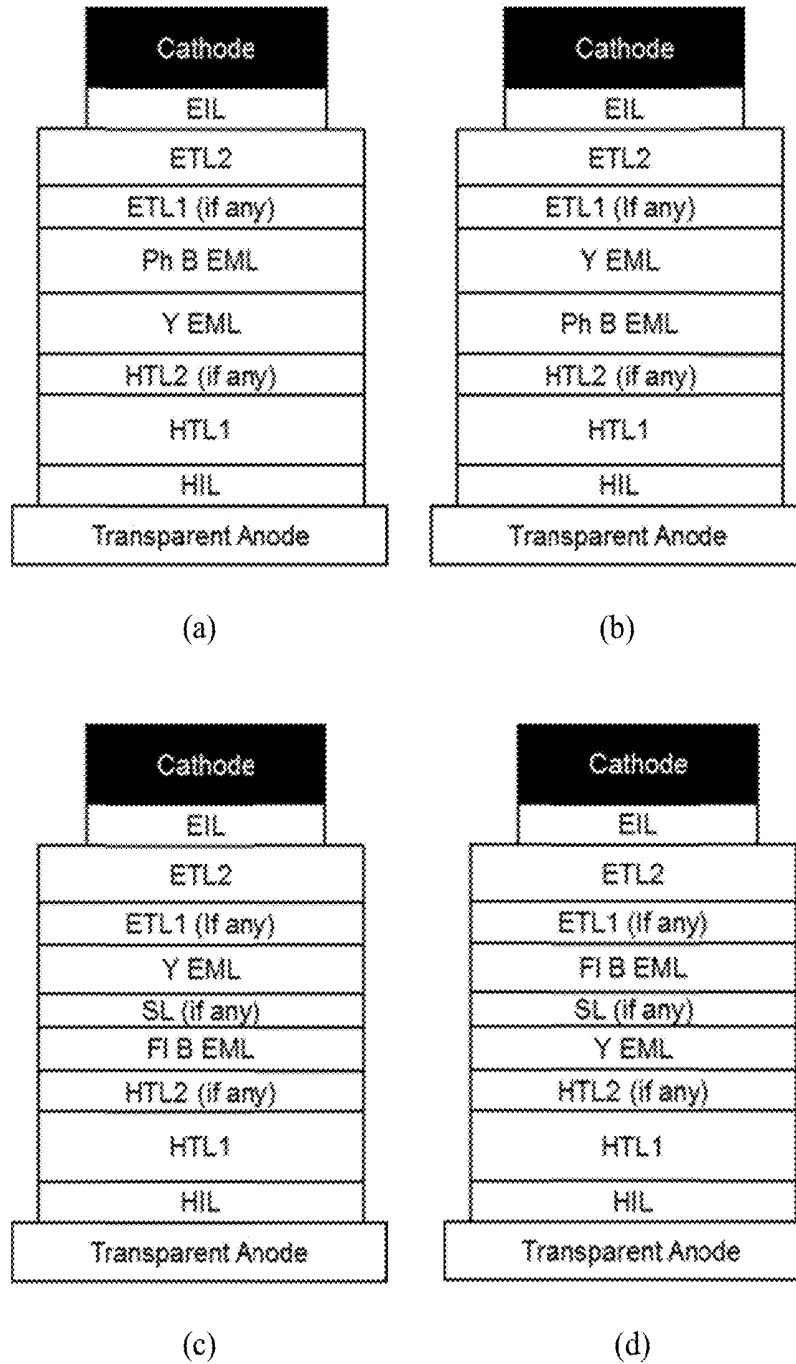

FIG. 4

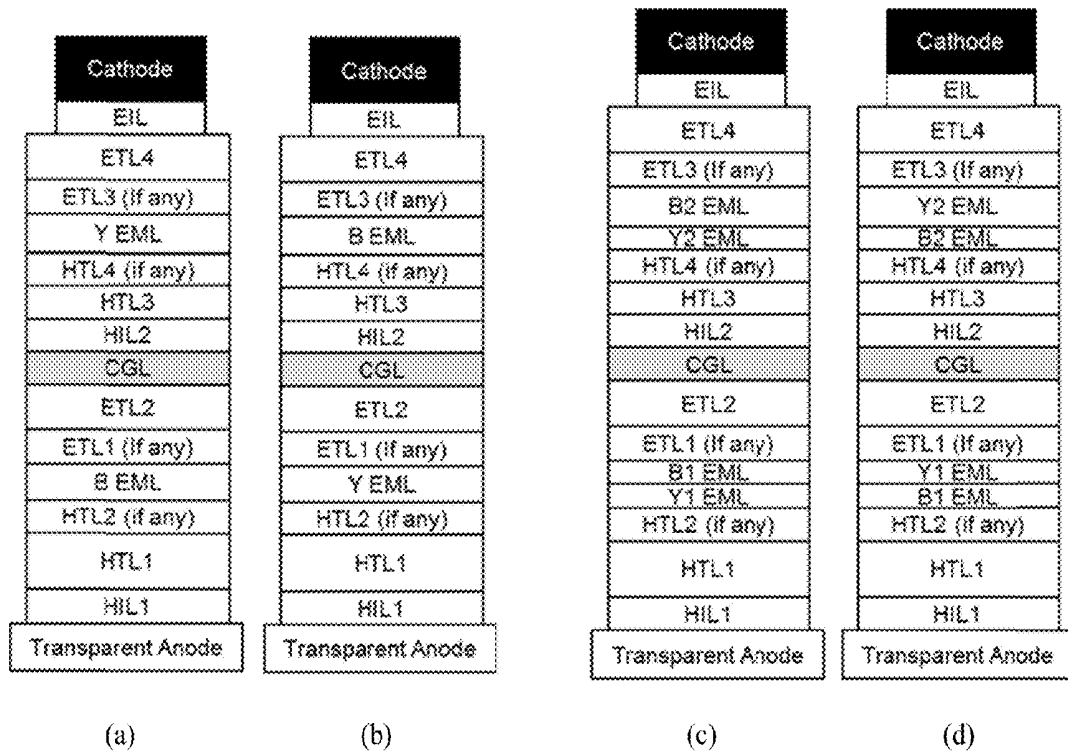
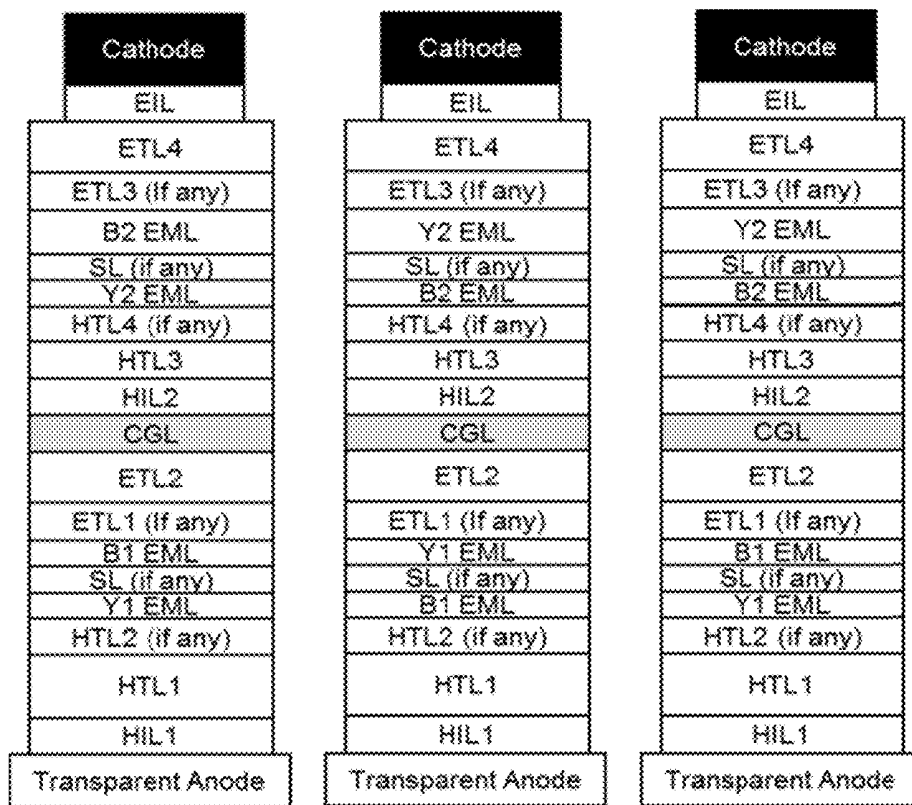

FIG. 5



(e)

(f)

(g)

FIG. 5

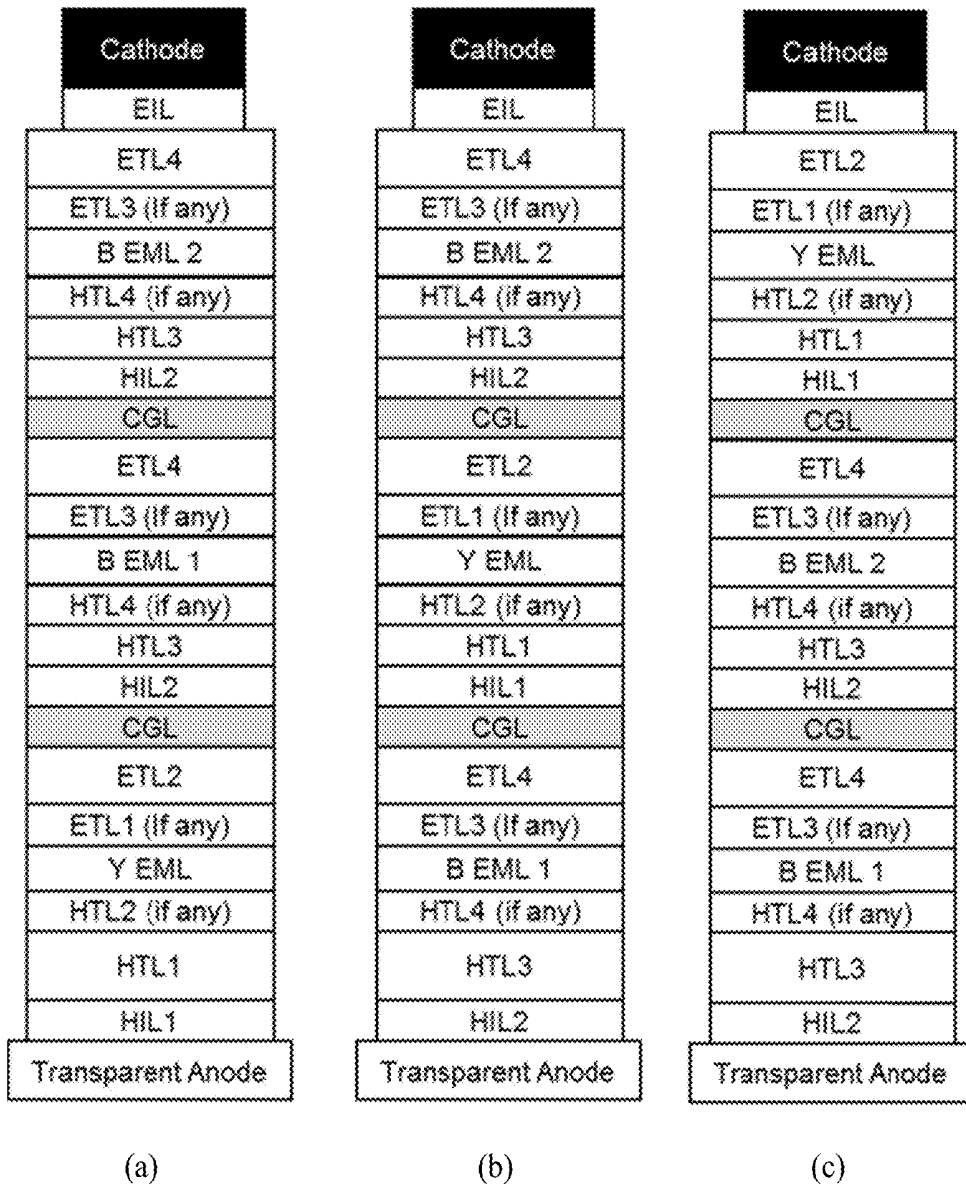

FIG. 6

## ORGANIC ELECTROLUMINESCENT MATERIALS AND DEVICES

### CROSS-REFERENCE TO RELATED APPLICATIONS

This application claims priority under 35 U.S.C. § 119(e) to U.S. Provisional Applications No. 61/940,603, filed on Feb. 17, 2014, No. 61/920,544, filed on Dec. 24, 2013, No. 61/894,160, filed on Oct. 22, 2013, No. 61/874,444, filed on Sep. 6, 2013, and No. 61/867,858, filed on Aug. 20, 2013, the entire contents of which are incorporated herein by reference.

### PARTIES TO A JOINT RESEARCH AGREEMENT

The claimed invention was made by, on behalf of, and/or in connection with one or more of the following parties to a joint university corporation research agreement: Regents of the University of Michigan, Princeton University, University of Southern California, and the Universal Display Corporation. The agreement was in effect on and before the date the claimed invention was made, and the claimed invention was made as a result of activities undertaken within the scope of the agreement.

### FIELD OF THE INVENTION

The present invention relates to organic light emitting devices (OLEDs), and more specifically to organic materials used in such devices. More specifically, the present invention relates to novel premixed host systems for phosphorescent OLEDs. At least one emitter and at least another material can be mixed and co-evaporated from one sublimation crucible in a vacuum thermal evaporation (VTE) process and achieve stable evaporation.

### BACKGROUND

Opto-electronic devices that make use of organic materials are becoming increasingly desirable for a number of reasons. Many of the materials used to make such devices are relatively inexpensive, so organic opto-electronic devices have the potential for cost advantages over inorganic devices. In addition, the inherent properties of organic materials, such as their flexibility, may make them well suited for particular applications such as fabrication on a flexible substrate. Examples of organic opto-electronic devices include organic light emitting devices (OLEDs), organic phototransistors, organic photovoltaic cells, and organic photodetectors. For OLEDs, the organic materials may have performance advantages over conventional materials. For example, the wavelength at which an organic emissive layer emits light may generally be readily tuned with appropriate dopants.

OLEDs make use of thin organic films that emit light when voltage is applied across the device. OLEDs are becoming an increasingly interesting technology for use in applications such as flat panel displays, illumination, and backlighting. Several OLED materials and configurations are described in U.S. Pat. Nos. 5,844,363, 6,303,238, and 5,707,745, which are incorporated herein by reference in their entirety.

One application for phosphorescent emissive molecules is a full color display. Industry standards for such a display call for pixels adapted to emit particular colors, referred to as

“saturated” colors. In particular, these standards call for saturated red, green, and blue pixels. Color may be measured using CIE coordinates, which are well known to the art.

One example of a green emissive molecule is tris(2-phenylpyridine) iridium, denoted Ir(ppy)<sub>3</sub>, which has the following structure:

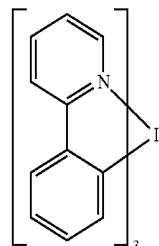

In this, and later figures herein, we depict the dative bond from nitrogen to metal (here, Ir) as a straight line.

As used herein, the term “organic” includes polymeric materials as well as small molecule organic materials that may be used to fabricate organic opto-electronic devices. “Small molecule” refers to any organic material that is not a polymer, and “small molecules” may actually be quite large. Small molecules may include repeat units in some circumstances. For example, using a long chain alkyl group as a substituent does not remove a molecule from the “small molecule” class. Small molecules may also be incorporated into polymers, for example as a pendent group on a polymer backbone or as a part of the backbone. Small molecules may also serve as the core moiety of a dendrimer, which consists of a series of chemical shells built on the core moiety. The core moiety of a dendrimer may be a fluorescent or phosphorescent small molecule emitter. A dendrimer may be a “small molecule,” and it is believed that all dendrimers currently used in the field of OLEDs are small molecules.

As used herein, “top” means furthest away from the substrate, while “bottom” means closest to the substrate. Where a first layer is described as “disposed over” a second layer, the first layer is disposed further away from substrate. There may be other layers between the first and second layer, unless it is specified that the first layer is “in contact with” the second layer. For example, a cathode may be described as “disposed over” an anode, even though there are various organic layers in between.

As used herein, “solution processable” means capable of being dissolved, dispersed, or transported in and/or deposited from a liquid medium, either in solution or suspension form.

A ligand may be referred to as “photoactive” when it is believed that the ligand directly contributes to the photoactive properties of an emissive material. A ligand may be referred to as “ancillary” when it is believed that the ligand does not contribute to the photoactive properties of an emissive material, although an ancillary ligand may alter the properties of a photoactive ligand.

As used herein, and as would be generally understood by one skilled in the art, a first “Highest Occupied Molecular Orbital” (HOMO) or “Lowest Unoccupied Molecular Orbital” (LUMO) energy level is “greater than” or “higher than” a second HOMO or LUMO energy level if the first energy level is closer to the vacuum energy level. Since ionization potentials (IP) are measured as a negative energy relative to a vacuum level, a higher HOMO energy level corresponds to an IP having a smaller absolute value (an IP

that is less negative). Similarly, a higher LUMO energy level corresponds to an electron affinity (EA) having a smaller absolute value (an EA that is less negative). On a conventional energy level diagram, with the vacuum level at the top, the LUMO energy level of a material is higher than the HOMO energy level of the same material. A “higher” HOMO or LUMO energy level appears closer to the top of such a diagram than a “lower” HOMO or LUMO energy level.

As used herein, and as would be generally understood by one skilled in the art, a first work function is “greater than” or “higher than” a second work function if the first work function has a higher absolute value. Because work functions are generally measured as negative numbers relative to vacuum level, this means that a “higher” work function is more negative. On a conventional energy level diagram, with the vacuum level at the top, a “higher” work function is illustrated as further away from the vacuum level in the downward direction. Thus, the definitions of HOMO and LUMO energy levels follow a different convention than work functions.

More details on OLEDs, and the definitions described above, can be found in U.S. Pat. No. 7,279,704, which is incorporated herein by reference in its entirety.

#### SUMMARY OF THE INVENTION

The present disclosure provides a novel composition comprising a mixture of a first compound and a second compound, wherein the first compound has different chemical structure than the second compound; wherein the first compound is capable of functioning as a phosphorescent emitter in an organic light emitting device at room temperature. The first compound can have an evaporation temperature T1 of 150 to 350° C. The second compound can have an evaporation temperature T2 of 150 to 350° C. In order to form the inventive composition comprising a mixture of the first compound and the second compound, the absolute value of T1–T2, the difference between T1 and T2, should be less than 20° C. The first compound has a concentration C1 in the mixture and a concentration C2 in a film formed by evaporating the mixture in a vacuum deposition tool at a constant pressure between  $1 \times 10^{-6}$  Torr to  $1 \times 10^{-9}$  Torr, at a 2 Å/sec deposition rate on a surface positioned at a predetermined distance away from the mixture being evaporated, and wherein the absolute value of  $(C1-C2)/C1$  is less than 5%.

According to an embodiment of the present disclosure, a first device comprising a first organic light emitting device, the first organic light emitting device comprising: an anode; a cathode; and an organic layer, disposed between the anode and the cathode, comprising a first composition further comprising a mixture of a first compound and a second compound, wherein the first compound has different chemical structure than the second compound;

wherein the first compound is capable of functioning as a phosphorescent emitter in an organic light emitting device at room temperature;

wherein the first compound has an evaporation temperature T1 of 150 to 350° C.;

wherein the second compound has an evaporation temperature T2 of 150 to 350° C.;

wherein the absolute value of T1–T2 is less than 20° C.;

wherein the first compound has a concentration C1 in said mixture, a concentration C2 in a film formed by evaporating the mixture in a vacuum deposition tool at a constant pressure between  $1 \times 10^{-6}$  Torr to  $1 \times 10^{-9}$  Torr, at a 2 Å/sec

deposition rate on a surface positioned at a predetermined distance away from the mixture being evaporated; and wherein the absolute value of  $(C1-C2)/C1$  is less than 5%.

According to an embodiment of the present disclosure, a method of fabricating an organic light emitting device comprising a first electrode, a second electrode, and a first organic layer disposed between the first electrode and the second electrode, wherein the first organic layer comprises a first organic composition further comprising a mixture of a first compound and a second compound, is disclosed. The method comprises:

providing a substrate having the first electrode disposed thereon;

depositing the first composition over the first electrode; and

depositing the second electrode over the first organic layer, wherein the first compound has different chemical structure than the second compound;

wherein the first compound is capable of functioning as a phosphorescent emitter in an organic light emitting device at room temperature;

wherein the first compound has an evaporation temperature T1 of 150 to 350° C.;

wherein the second compound has an evaporation temperature T2 of 150 to 350° C.;

wherein the absolute value of T1–T2 is less than 20° C.;

wherein the first compound has a concentration C1 in said mixture, and a concentration C2 in a film formed by evaporating the mixture in a vacuum deposition tool at a constant pressure between  $1 \times 10^{-6}$  Torr to  $1 \times 10^{-9}$  Torr, at a 2 Å/sec deposition rate on a surface positioned at a predefined distance away from the mixture being evaporated; and wherein the absolute value of  $(C1-C2)/C1$  is less than 5%.

#### BRIEF DESCRIPTION OF THE DRAWINGS

FIG. 1 shows an organic light emitting device that can incorporate the inventive host material disclosed herein.

FIG. 2 shows an inverted organic light emitting device that can incorporate the inventive host material disclosed herein.

FIGS. 3(a)-3(c) show examples of white OLEDs in top emission, bottom emission and transparent OLEDs (TOLED) configurations.

FIGS. 4(a)-4(d) show examples of blue-yellow white OLED structures.

FIGS. 5(a)-5(g) show examples of two-unit white stacked OLED structures.

FIGS. 6(a)-6(c) show examples of white stacked OLED structures having three or more units.

#### DETAILED DESCRIPTION

Generally, an OLED comprises at least one organic layer disposed between and electrically connected to an anode and a cathode. When a current is applied, the anode injects holes and the cathode injects electrons into the organic layer(s). The injected holes and electrons each migrate toward the oppositely charged electrode. When an electron and hole localize on the same molecule, an “exciton,” which is a localized electron-hole pair having an excited energy state, is formed. Light is emitted when the exciton relaxes via a photoemissive mechanism. In some cases, the exciton may be localized on an excimer or an exciplex. Non-radiative mechanisms, such as thermal relaxation, may also occur, but are generally considered undesirable.

The initial OLEDs used emissive molecules that emitted light from their singlet states (“fluorescence”) as disclosed, for example, in U.S. Pat. No. 4,769,292, which is incorporated by reference in its entirety. Fluorescent emission generally occurs in a time frame of less than 10 nanoseconds.

More recently, OLEDs having emissive materials that emit light from triplet states (“phosphorescence”) have been demonstrated. Baldo et al., “Highly Efficient Phosphorescent Emission from Organic Electroluminescent Devices,” *Nature*, vol. 395, 151-154, 1998; (“Baldo-I”) and Baldo et al., “Very high-efficiency green organic light-emitting devices based on electrophosphorescence,” *Appl. Phys. Lett.*, vol. 75, No. 3, 4-6 (1999) (“Baldo-II”), which are incorporated by reference in their entireties. Phosphorescence is described in more detail in U.S. Pat. No. 7,279,704 at cols. 5-6, which are incorporated by reference.

FIG. 1 shows an organic light emitting device **100**. The figures are not necessarily drawn to scale. Device **100** may include a substrate **110**, an anode **115**, a hole injection layer **120**, a hole transport layer **125**, an electron blocking layer **130**, an emissive layer **135**, a hole blocking layer **140**, an electron transport layer **145**, an electron injection layer **150**, a protective layer **155**, a cathode **160**, and a barrier layer **170**. Cathode **160** is a compound cathode having a first conductive layer **162** and a second conductive layer **164**. Device **100** may be fabricated by depositing the layers described, in order. The properties and functions of these various layers, as well as example materials, are described in more detail in U.S. Pat. No. 7,279,704 at cols. 6-10, which are incorporated by reference.

More examples for each of these layers are available. For example, a flexible and transparent substrate-anode combination is disclosed in U.S. Pat. No. 5,844,363, which is incorporated by reference in its entirety. An example of a p-doped hole transport layer is m-MTDATA doped with F<sub>4</sub>-TCNQ at a molar ratio of 50:1, as disclosed in U.S. Patent Application Publication No. 2003/0230980, which is incorporated by reference in its entirety. Examples of host materials are disclosed in U.S. Pat. No. 6,303,238 to Thompson et al., which is incorporated by reference in its entirety. An example of an n-doped electron transport layer is BPhen doped with Li at a molar ratio of 1:1, as disclosed in U.S. Patent Application Publication No. 2003/0230980, which is incorporated by reference in its entirety. U.S. Pat. Nos. 5,703,436 and 5,707,745, which are incorporated by reference in their entireties, disclose examples of cathodes including compound cathodes having a thin layer of metal such as Mg:Ag with an overlying transparent, electrically-conductive, sputter-deposited ITO layer. The theory and use of blocking layers is described in more detail in U.S. Pat. No. 6,097,147 and U.S. Patent Application Publication No. 2003/0230980, which are incorporated by reference in their entireties. Examples of injection layers are provided in U.S. Patent Application Publication No. 2004/0174116, which is incorporated by reference in its entirety. A description of protective layers may be found in U.S. Patent Application Publication No. 2004/0174116, which is incorporated by reference in its entirety.

FIG. 2 shows an inverted OLED **200**. The device includes a substrate **210**, a cathode **215**, an emissive layer **220**, a hole transport layer **225**, and an anode **230**. Device **200** may be fabricated by depositing the layers described, in order. Because the most common OLED configuration has a cathode disposed over the anode, and device **200** has cathode **215** disposed under anode **230**, device **200** may be referred to as an “inverted” OLED. Materials similar to those

described with respect to device **100** may be used in the corresponding layers of device **200**. FIG. 2 provides one example of how some layers may be omitted from the structure of device **100**.

The simple layered structure illustrated in FIGS. 1 and 2 is provided by way of non-limiting example, and it is understood that embodiments of the invention may be used in connection with a wide variety of other structures. The specific materials and structures described are exemplary in nature, and other materials and structures may be used. Functional OLEDs may be achieved by combining the various layers described in different ways, or layers may be omitted entirely, based on design, performance, and cost factors. Other layers not specifically described may also be included. Materials other than those specifically described may be used. Although many of the examples provided herein describe various layers as comprising a single material, it is understood that combinations of materials, such as a mixture of host and dopant, or more generally a mixture, may be used. Also, the layers may have various sublayers. The names given to the various layers herein are not intended to be strictly limiting. For example, in device **200**, hole transport layer **225** transports holes and injects holes into emissive layer **220**, and may be described as a hole transport layer or a hole injection layer. In one embodiment, an OLED may be described as having an “organic layer” disposed between a cathode and an anode. This organic layer may comprise a single layer, or may further comprise multiple layers of different organic materials as described, for example, with respect to FIGS. 1 and 2.

Structures and materials not specifically described may also be used, such as OLEDs comprised of polymeric materials (PLEDs) such as disclosed in U.S. Pat. No. 5,247,190 to Friend et al., which is incorporated by reference in its entirety. By way of further example, OLEDs having a single organic layer may be used. OLEDs may be stacked, for example as described in U.S. Pat. No. 5,707,745 to Forrest et al., which is incorporated by reference in its entirety. The OLED structure may deviate from the simple layered structure illustrated in FIGS. 1 and 2. For example, the substrate may include an angled reflective surface to improve out-coupling, such as a mesa structure as described in U.S. Pat. No. 6,091,195 to Forrest et al., and/or a pit structure as described in U.S. Pat. No. 5,834,893 to Bulovic et al., which are incorporated by reference in their entireties.

Unless otherwise specified, any of the layers of the various embodiments may be deposited by any suitable method. For the organic layers, preferred methods include thermal evaporation, ink-jet, such as described in U.S. Pat. Nos. 6,013,982 and 6,087,196, which are incorporated by reference in their entireties, organic vapor phase deposition (OVPD), such as described in U.S. Pat. No. 6,337,102 to Forrest et al., which is incorporated by reference in its entirety, and deposition by organic vapor jet printing (OVJP), such as described in U.S. Pat. No. 7,431,968, which is incorporated by reference in its entirety. Other suitable deposition methods include spin coating and other solution based processes. Solution based processes are preferably carried out in nitrogen or an inert atmosphere. For the other layers, preferred methods include thermal evaporation. Preferred patterning methods include deposition through a mask, cold welding such as described in U.S. Pat. Nos. 6,294,398 and 6,468,819, which are incorporated by reference in their entireties, and patterning associated with some of the deposition methods such as ink-jet and OVJD. Other methods may also be used. The materials to be deposited may be modified to make them compatible with a particular

deposition method. For example, substituents such as alkyl and aryl groups, branched or unbranched, and preferably containing at least 3 carbons, may be used in small molecules to enhance their ability to undergo solution processing. Substituents having 20 carbons or more may be used, and 3-20 carbons is a preferred range. Materials with asymmetric structures may have better solution processability than those having symmetric structures, because asymmetric materials may have a lower tendency to recrystallize. Dendrimer substituents may be used to enhance the ability of small molecules to undergo solution processing.

Devices fabricated in accordance with embodiments of the present invention may further optionally comprise a barrier layer. One purpose of the barrier layer is to protect the electrodes and organic layers from damaging exposure to harmful species in the environment including moisture, vapor and/or gases, etc. The barrier layer may be deposited over, under or next to a substrate, an electrode, or over any other parts of a device including an edge. The barrier layer may comprise a single layer, or multiple layers. The barrier layer may be formed by various known chemical vapor deposition techniques and may include compositions having a single phase as well as compositions having multiple phases. Any suitable material or combination of materials may be used for the barrier layer. The barrier layer may incorporate an inorganic or an organic compound or both. The preferred barrier layer comprises a mixture of a polymeric material and a non-polymeric material as described in U.S. Pat. No. 7,968,146, PCT Pat. Application Nos. PCT/US2007/023098 and PCT/US2009/042829, which are herein incorporated by reference in their entireties. To be considered a "mixture", the aforesaid polymeric and non-polymeric materials comprising the barrier layer should be deposited under the same reaction conditions and/or at the same time. The weight ratio of polymeric to non-polymeric material may be in the range of 95:5 to 5:95. The polymeric material and the non-polymeric material may be created from the same precursor material. In one example, the mixture of a polymeric material and a non-polymeric material consists essentially of polymeric silicon and inorganic silicon.

Devices fabricated in accordance with embodiments of the invention may be incorporated into a wide variety of consumer products, including flat panel displays, computer monitors, medical monitors, televisions, billboards, lights for interior or exterior illumination and/or signaling, heads up displays, fully transparent displays, flexible displays, laser printers, telephones, cell phones, personal digital assistants (PDAs), laptop computers, digital cameras, camcorders, viewfinders, micro-displays, 3-D displays, vehicles, a large area wall, theater or stadium screen, or a sign. Various control mechanisms may be used to control devices fabricated in accordance with the present invention, including passive matrix and active matrix. Many of the devices are intended for use in a temperature range comfortable to humans, such as 18 degrees C. to 30 degrees C., and more preferably at room temperature (20-25 degrees C.), but could be used outside this temperature range, for example, from -40 degree C. to +80 degree C.

The materials and structures described herein may have applications in devices other than OLEDs. For example, other optoelectronic devices such as organic solar cells and organic photodetectors may employ the materials and structures. More generally, organic devices, such as organic transistors, may employ the materials and structures.

The term "halo" or "halogen" as used herein includes fluorine, chlorine, bromine, and iodine.

The term "alkyl" as used herein contemplates both straight and branched chain alkyl radicals. Preferred alkyl groups are those containing from one to fifteen carbon atoms and includes methyl, ethyl, propyl, isopropyl, butyl, isobutyl, tert-butyl, and the like. Additionally, the alkyl group may be optionally substituted.

The term "cycloalkyl" as used herein contemplates cyclic alkyl radicals. Preferred cycloalkyl groups are those containing 3 to 7 carbon atoms and includes cyclopropyl, cyclopentyl, cyclohexyl, and the like. Additionally, the cycloalkyl group may be optionally substituted.

The term "alkenyl" as used herein contemplates both straight and branched chain alkene radicals. Preferred alkenyl groups are those containing two to fifteen carbon atoms. Additionally, the alkenyl group may be optionally substituted.

The term "alkynyl" as used herein contemplates both straight and branched chain alkyne radicals. Preferred alkynyl groups are those containing two to fifteen carbon atoms. Additionally, the alkynyl group may be optionally substituted.

The terms "aralkyl" or "arylalkyl" as used herein are used interchangeably and contemplate an alkyl group that has as a substituent an aromatic group. Additionally, the aralkyl group may be optionally substituted.

The term "heterocyclic group" as used herein contemplates aromatic and non-aromatic cyclic radicals. Hetero-aromatic cyclic radicals also refer to heteroaryl. Preferred hetero-non-aromatic cyclic groups are those containing 3 or 7 ring atoms which includes at least one hetero atom, and includes cyclic amines such as morpholino, piperidino, pyrrolidino, and the like, and cyclic ethers, such as tetrahydrofuran, tetrahydropyran, and the like. Additionally, the heterocyclic group may be optionally substituted.

The term "aryl" or "aromatic group" as used herein contemplates single-ring groups and polycyclic ring systems. The polycyclic rings may have two or more rings in which two carbons are common to two adjoining rings (the rings are "fused") wherein at least one of the rings is aromatic, e.g., the other rings can be cycloalkyls, cycloalkenyls, aryl, heterocycles, and/or heteroaryls. Additionally, the aryl group may be optionally substituted.

The term "heteroaryl" as used herein contemplates single-ring hetero-aromatic groups that may include from one to three heteroatoms, for example, pyrrole, furan, thiophene, imidazole, oxazole, thiazole, triazole, pyrazole, pyridine, pyrazine and pyrimidine, and the like. The term heteroaryl also includes polycyclic hetero-aromatic systems having two or more rings in which two atoms are common to two adjoining rings (the rings are "fused") wherein at least one of the rings is a heteroaryl, e.g., the other rings can be cycloalkyls, cycloalkenyls, aryl, heterocycles, and/or heteroaryls. Additionally, the heteroaryl group may be optionally substituted.

The alkyl, cycloalkyl, alkenyl, alkynyl, aralkyl, heterocyclic group, aryl, and heteroaryl may be optionally substituted with one or more substituents selected from the group consisting of hydrogen, deuterium, halogen, alkyl, cycloalkyl, heteroalkyl, arylalkyl, alkoxy, aryloxy, amino, cyclic amino, silyl, alkenyl, cycloalkenyl, heteroalkenyl, alkynyl, aryl, heteroaryl, acyl, carbonyl, carboxylic acid, ether, ester, nitrile, isonitrile, sulfanyl, sulfinyl, sulfonyl, phosphino, and combinations thereof.

As used herein, "substituted" indicates that a substituent other than H is bonded to the relevant position, such as carbon. Thus, for example, where R<sup>1</sup> is mono-substituted, then one R<sup>1</sup> must be other than H. Similarly, where R<sup>1</sup> is

di-substituted, then two of R<sup>1</sup> must be other than H. Similarly, where R<sup>1</sup> is unsubstituted, R<sup>1</sup> is hydrogen for all available positions.

The “aza” designation in the fragments described herein, i.e. aza-dibenzofuran, aza-dibenzonethiophene, etc. means that one or more of the C—H groups in the respective fragment can be replaced by a nitrogen atom, for example, and without any limitation, azatriphenylene encompasses both dibenzo[f,h]quinoxaline and dibenzo[f,h]quinoline. One of ordinary skill in the art can readily envision other nitrogen analogs of the aza-derivatives described above, and all such analogs are intended to be encompassed by the terms as set forth herein.

It is to be understood that when a molecular fragment is described as being a substituent or otherwise attached to another moiety, its name may be written as if it were a fragment (e.g. naphthyl, dibenzofuryl) or as if it were the whole molecule (e.g. naphthalene, dibenzofuran). As used herein, these different ways of designating a substituent or attached fragment are considered to be equivalent.

Often, the emissive layer (EML) of OLED devices exhibiting good lifetime and efficiency requires more than two components (e.g. 3 or 4 components). Fabricating such EMLs using vacuum thermal evaporation (VTE) process then requires evaporating 3 or 4 evaporation source materials in separate VTE sublimation crucibles, which is very complicated and costly compared to a standard two-component EML with a single host and an emitter, which requires only two evaporation sources.

Premixing two or more materials and evaporating them from one VTE sublimation crucible can reduce the complexity of the fabrication process. However, the co-evaporation must be stable and produce an evaporated film having a composition that remains constant through the evaporation process. Variations in the film’s composition may adversely affect the device performance. In order to obtain a stable co-evaporation from a mixture of compounds under vacuum, one would assume that the materials must have the same evaporation temperature under the same condition. However, this may not be the only parameter one has to consider. When two compounds are mixed together, they may interact with each other and the evaporation property of the mixture may differ from their individual properties. On the other hand, materials with slightly different evaporation temperatures may form a stable co-evaporation mixture. Therefore, it is extremely difficult to achieve a stable co-evaporation mixture. So far, there have been very few stable co-evaporation mixture examples. “Evaporation temperature” of a material is measured in a vacuum deposition tool at a constant pressure, normally between  $1 \times 10^{-7}$  Torr to  $1 \times 10^{-8}$  Torr, at a 2 Å/sec deposition rate on a surface positioned at a set distance away from the evaporation source of the material being evaporated, e.g. sublimation crucible in a VTE tool. The various measured values such as temperature, pressure, deposition rate, etc. disclosed herein are expected to have nominal variations because of the expected tolerances in the measurements that produced these quantitative values as understood by one of ordinary skill in the art.

Many factors other than temperature can contribute to the ability to achieve stable co-evaporation, such as the miscibility of the different materials and the phase transition temperatures of the different materials. The inventors found that when two materials have similar evaporation temperatures, and similar mass loss rate or similar vapor pressures, the two materials can co-evaporate consistently. “Mass loss rate” of a material is defined as the percentage of mass lost

over time (“percentage/minute” or “%/min”) and is determined by measuring the time it takes to lose the first 10% of the mass of a sample of the material as measured by thermal gravity analysis (TGA) under a given experimental condition at a given constant temperature for a given material after the a steady evaporation state is reached. The given constant temperature is one temperature point that is chosen so that the value of mass loss rate is between about 0.05 to 0.50%/min. A skilled person in this field should appreciate that in order to compare two parameters, the experimental condition should be consistent. The method of measuring mass loss rate and vapor pressure is well known in the art and can be found, for example, in Bull. et al. Mater. Sci. 2011, 34, 7.

In the state of the art phosphorescent OLED devices, the EML may consist of three or more components. In one example, the EML can consist of two host-type compounds and an emitter combination (e.g. a hole transporting cohost (h-host), an electron transporting cohost (e-host), and a compound capable of functioning as a phosphorescent emitter in an OLED at room temperature). In another example, the EML can consist of one host-type compound and two emitter-type compounds (e.g., a host compound and two compounds each capable of functioning as a phosphorescent emitter in an OLED at room temperature). Conventionally, in order to fabricate such EMLs having three or more components using VTE process, three or more evaporation sources are required, one for each of the components. Because the concentration of the components are important for the device performance, typically, the rate of deposition of each component is measured individually during the deposition process. This makes the VTE process complicated and costly. Thus, it is desired to premix at least two of the components of such EMLs to reduce the number of VTE evaporation sources.

As used herein, an “emitter-type compound” refers to a compound that is capable of functioning as a phosphorescent emitter in the EML of an OLED at room temperature. A “host-type compound” refers to a compound that is capable of functioning as a host material in the EML of an OLED at room temperature.

If any two of the three or more components of the EMLs can be premixed and form a stable mixture of co-evaporation source, then the number of evaporation sources required for EML layer fabrication would be reduced. In order for materials to be premixable into an evaporation source, they should co-evaporate and deposit uniformly without changing the ratio. The ratio of the components in the mixture should be the same as the ratio of the components in the evaporation deposited films from these premixed materials. Therefore, the concentration of the two components in the deposited film is controlled by their concentration in the premixed evaporation source.

The present disclosure describes a new class of emitters and another class of materials (such as host-type materials) which can be premixed to provide a VTE co-evaporation source that can be used for a stable co-evaporation of the two materials.

Maximizing the efficiency of a phosphorescent emitter in an OLED may involve narrowing the emission spectrum. This side effect of narrowed emission is not desirable in some applications, such as, when the emitter is used as part of a white emitting OLED. In applications such as for white emitting OLEDs, often a broad full width half maximum (FWHM) spectrum is preferred.

One possible approach to achieving both high efficiency and a broad FWHM spectrum is to incorporate two emitters

within a device. This can be done by incorporating the emitters in separate EMLs or depositing two emitters into one layer. The inventors have discovered that by premixing two emitters that have similar thermal evaporation properties in a desired ratio and depositing the material by evaporation using a VTE process from one evaporation sublimation crucible containing the mixed composition source material, the manufacturing of OLEDs having an EML comprising the two emitters can be simplified.

The combination of premixed compounds described in this disclosure, where at least one of the compounds is an emitter-type compound, can be used for fine tuning device emission spectra for a specific spectral width without compromising the device efficiency. Premixing allows for a greater control of the ratio of the components of the EML layer thereby more accurately enabling the desired/resultant spectral shape than when evaporating the components of the EML layer from separate evaporation sources. This provides a more robust manufacturing process for OLEDs.

According to the present disclosure, the composition of the film deposited by VTE from a premixed emitter evaporation source material is determined in advance at the mixing stage. The composition of the premixed emitter evaporation source material is determined by the desired contribution of the two emitter-type compounds used. The ratio of the two emitter-type compounds in the composition of the premix may be between 1:1 to 200:1. Preferably, the ratio is between 1:1 to 50:1, more preferably between 1:1 and 20:1, more preferably between 1:1 to 5:1, and most preferably between 1:1 to 2:1.

#### EXAMPLES

In a first example, a novel combination of two emitter-type compounds, Compound 20 and Compound 145, having very similar sublimation properties are premixed together, placed in a single deposition source and evaporated into a device EML with a variable ratio. For example, a mixture of these two emitters was deposited at 0.2 Å/s for a film 2000 Å thick. Material was then deposited onto a substrate at a deposition rate of 1 Å/s to yield a film of 70 nm thick. The ratio of the two emitters in the premixture, as measured by weight prior to mixing, was 85% (Compound 20) to 15% (Compound 145). The composition of the premixture, as measured by high pressure liquid chromatography (HPLC), was 84.5% (Compound 20) to 15.5% (Compound 145). Because mixing can lead to non-uniformities within the total premixture, an error bar of 1% is given for the measured % of the premixture components when a small sample is analyzed by HPLC. The composition of the deposited film, as measured by HPLC, was 85.3% (Compound 20) to 14.7% (Compound 145). Therefore, the compositions of the premixture and deposited material are equivalent.

The novel two-compound mixture combinations disclosed herein can be used in making various white OLED configurations. For example, the two-compound mixture combinations disclosed herein can be used to make premixed emitter evaporation source materials that can be used in depositing broad yellow EML layers in blue-yellow white OLEDs.

Examples of the various configurations for such blue-yellow white OLEDs are illustrated in FIGS. 3(a) through 6(c). The layers “Y EML,” “Y1 EML,” and “Y2 EML” in the figures are the broad yellow EMLs and as well known in the art, the broad yellow EML layers often consist of two emitter-type compounds in order to achieve the desired emission spectrum required for producing white light in

conjunction with the blue EML layers. The layers “Ph B EML,” “F1 B EML,” “B1 EML,” “B1 EML,” and “B2 EML” in the figures are the blue EMLs.

In these examples, the broad yellow EML layers are made of two emitter-type compounds to produce light in desired red-green, red-yellow, or yellow spectrum that when combined with the blue emission from the blue EML to produce white light emitting OLEDs. The premixed emitter evaporation source materials disclosed herein is useful for depositing these broad yellow EML layers by VTE process.

FIGS. 3(a)-3(c) show basic configurations for blue-yellow white OLEDs. FIG. 3(a) shows an example of blue-yellow white OLEDs in a bottom emission configuration (anode is transparent). FIG. 3(b) shows an example of a blue-yellow white OLED in a transparent OLED configuration (both anode and cathode are transparent). FIG. 3(c) shows an example of a blue-yellow white OLED in a top emission configuration (cathode is transparent). The examples shown in FIGS. 4(a)-6(c) are all shown in the bottom emission configuration but one skilled in the art would readily understand that the examples shown in FIGS. 4(a)-6(c) are equally applicable to the top emission configuration and transparent OLED configurations.

FIGS. 4(a)-4(d) show examples of single-unit blue-yellow white OLED structures. FIGS. 5(a)-5(g) show examples of two-unit blue-yellow white stacked OLED structures. FIGS. 6(a)-6(c) show examples of three-unit blue-yellow white stacked OLED structures. One skilled in the art would readily understand that these stacked OLED configurations can be applied to embodiments having more than three light emitting units. In these figures, the following abbreviations are used: HIL—hole injection layer, HTL—hole transporter layer, EML—emissive layer, ETL—electron transporter layer, EIL—electron injection layer, SL—separation layer, CGL—charge generation layer, Ph—phosphorescent, Fl—fluorescent. In these configurations, HIL2 can be the same material as HIL1 or a different material, HTL3 can be the same material as HTL1 or a different material, HTL4 can be the same material as HTL2 or a different material, ETL3 can be the same material as ETL1 or a different material, and ETL4 can be the same material as ETL2 or a different material. B EML, B1 EML and B2 EML are blue EMLs and they can be either fluorescent or phosphorescent. B2 EML can be the same material as B1 EML or a different material, Y EML, Y1 EML, and Y2 EML are yellow EMLs and they can be either fluorescent or phosphorescent. Y2 EML can be the same material as Y1 EML or a different material.

In the white stacked OLED structures of FIGS. 6(a)-6(c), HIL2 can be the same material as HIL1 or a different material, HTL3 can be the same material as HTL1 or a different material, HTL4 can be the same material as HTL2 or a different material, ETL3 can be the same material as ETL1 or a different material, and ETL4 can be the same material as ETL2 or a different material. B EML1 and B EML2 represent blue EMLs and can be either fluorescent or phosphorescent. B EML1 can be the same material as B EML2 or a different material. Y EML represent yellow EML. The number of stacked units can be any number greater than or equal to 3. The number of blue and yellow EML units can be any number. The stacked units can be in any order, e.g. B/Y/B/Y or B/B/Y/Y, or B/Y/B/Y/B, etc., where B denotes blue and Y denotes broad yellow.

According to another aspect of the present disclosure, a second example of premixed emitter evaporation source is disclosed. The premixed mixture according to this second example, comprises one emitter-type compound, Compound E5, and one host compound, Compound H1. Compound H1

## 13

and Compound E5 demonstrated premixability, which means they can be premixed and codeposited from one evaporation source without changing the composition. Uniform coevaporation of host:emitter pair is desired for the consistency of the device performance fabricated from this premixed precursor. The structures of Compound H1 and Compound E5 are shown below:

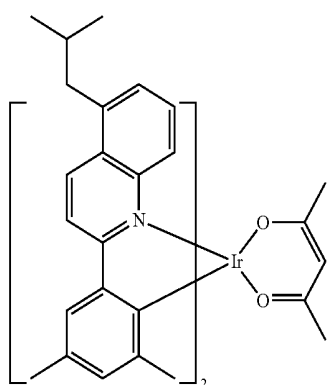
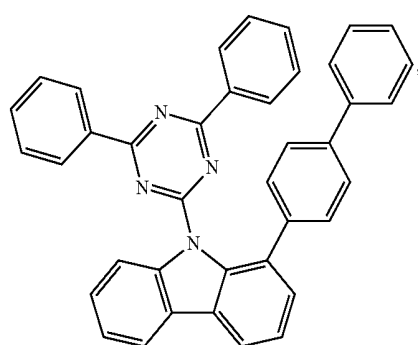

The premixability of Compound H1 and Compound E5 was tested by HPLC analysis of evaporated films. For this purpose the host Compound H1 (0.485 g) and emitter Compound E5 (0.015 g) were mixed and grinded to form 0.5 g of the mixture. The mixture was loaded into the evaporation source of the vacuum VTE chamber. The chamber was pumped down to  $10^{-7}$  Torr pressure. The premixed components were deposited at rate 2 Å/s onto glass substrates. The substrates were replaced continuously after deposition of 1100 Å of film without stopping the deposition and cooling the source. The premixed material was evaporated until depletion.

The deposit films were analyzed by HPLC (HPLC Conditions C18, 80-100 (CH<sub>3</sub>CN concentration in CH<sub>3</sub>CN and H<sub>2</sub>O), 30 min, detected wavelength 254 nm) and results are shown in Table 1 below. The composition of the host Compound H1 and emitter Compound E5 did not change significantly from Plate 1 to Plate 3. Each of the sample substrates are labeled Plate 1, Plate 2, and Plate 3. Some fluctuations in the concentration do not reveal any trend and can be explained by the accuracy of HPLC analysis.

## 14

TABLE 1

HPLC composition (%) of sequentially deposited films from a premixed host:emitter pair (host Compound H1 and emitter Compound E5) evaporation source.

Plate #	Films (1100 Å)	
	H1 [%]	E5 [%]
1	98.0	2.0
2	98.1	1.9
3	97.8	2.2

This data shows that host Compound H1 and emitter Compound E5 and potentially the other hosts and emitters from these families can be premixed to be used as single evaporation sources for an EML or part of the EML for PHOLEDs.

Examples of other possible premixed host:emitter pairs are provided in Table 2 below.

TABLE 2

Examples of possible premix pairs

Mixture number	Electron transporting host	Emitter Metal complex
1	Compound H1	Compound E5
2	Compound H14	Compound E1
3	Compound H21	Compound E4
4	Compound H30	Compound E9
5	Compound H21	Compound E17
6	Compound H33	Compound E13

Host Compound EH40 and emitter Compound 97 show premixability also. It means that they can be premixed and codeposited from one source without changing the composition. Uniform coevaporation of host:emitter is critical for the consistency of the devices performance fabricated from this premixed precursor. The structures of host Compound EH40 and emitter Compound 97 are shown below,

Compound EH40

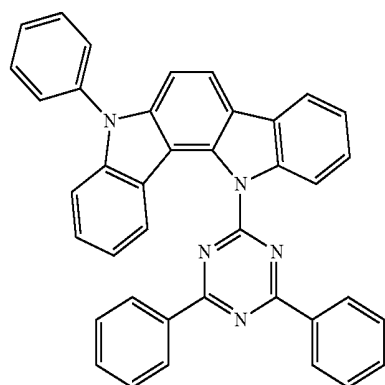

15

-continued

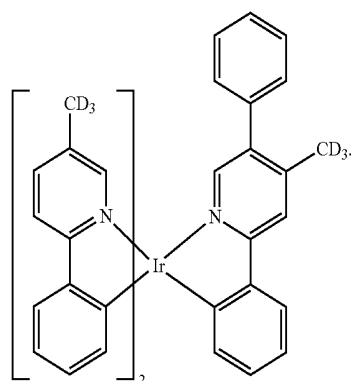

The premixability of Compound EH40 and Compound 97 was tested by HPLC analysis of evaporated films. For this purpose the host Compound EH40 and emitter Compound 97 were mixed in the ratio ~7:1 and grinded to form 0.2 g of the mixture. The mixture was loaded into the evaporation source of the vacuum VTE chamber. The chamber was pumped down to  $10^{-7}$  Torr pressure. The premixed components were deposited at rate 2 Å/s onto glass substrates. The substrates were replaced continuously after deposition of 500 Å of film without stopping the deposition and cooling the source. The premixed material was evaporated until depletion.

The films were analyzed by HPLC (HPLC Conditions C18, 100%  $\text{CH}_3\text{CN}$ , 30 min, detected wavelength 254 nm) and results are shown in Table 3. The composition of the host Compound EH40 and emitter Compound 97 did not change significantly from Plate 1 to Plate 5. Each of the sample substrates are labeled Plate 1, Plate 2, and Plate 3. Some fluctuations in the concentration do not reveal any trend and can be explained by the accuracy of HPLC analysis.

TABLE 3

HPLC composition (%) of sequentially deposited films from premixed host:emitter (Host Compound EH40:Emitter Compound 97 in ratio of ~7:1) evaporation source.		
Films (500 Å)	Host Compound EH40 (%)	Emitter Compound 97 (%)
Plate1	87.2	12.8
Plate2	87.1	12.9
Plate3	87.5	12.5
Plate4	87.6	12.4
Plate5	87.9	12.1

This is the evidence that host Compound EH40 and emitter Compound 97, and potentially the other hosts and emitters from these families can be premixed to be used as single evaporation sources for an EML or part of the EML for PHOLEDs. Examples of other possible premixed host:emitter pairs are provided in Table 4 below.

TABLE 4

Examples of possible premix pairs of host:emitter.		
Mixture number	Electron transporting host	Emitter Metal complex
1	Compound EH1	Compound 4
2	Compound EH2	Compound 7

16

TABLE 4-continued

Examples of possible premix pairs of host:emitter.			
Mixture number	Electron transporting host	Emitter Metal complex	
5	3	Compound EH4	Compound 3
	4	Compound EH5	Compound 11
	5	Compound EH8	Compound 1
	6	Compound EH8	Compound 67
10	7	Compound EH16	Compound 21
	8	Compound EH28	Compound 29
	9	Compound EH40	Compound 34
	10	Compound EH40	Compound 97

According to an aspect of the present disclosure, a composition comprising a mixture of a first compound and a second compound is now described. In the mixture, the first compound has a different chemical structure than the second compound. The first compound is capable of functioning as a phosphorescent emitter in an OLED at room temperature. The first compound has an evaporation temperature T1 of 150 to 350° C. and the second compound has an evaporation temperature T2 of 150 to 350° C., wherein the absolute value of T1-T2, i.e. the difference between T1 and T2, is less than 20° C. Preferably, the absolute value of T1-T2 is less than 10° C. and more preferably less than 5° C.

The first compound has a concentration C1 in the mixture and a concentration C2 in a film formed by evaporating the mixture in a vacuum deposition tool at a constant pressure between  $1 \times 10^{-6}$  Torr to  $1 \times 10^{-9}$  Torr, at a 2 Å/sec deposition rate on a surface positioned at a predefined distance away from the evaporation source of the mixture being evaporated, and wherein the absolute value of  $(C1-C2)/C1$  is less than 5%. Preferably, the absolute value of  $(C1-C2)/C1$  is less than 3%.

The concentrations C1 and C2 are relative concentrations of the first compound. Therefore, the conditional requirement for the two compounds forming the mixture described above means that the relative concentration of the first compound in the as-deposited film (C2) should be as close to the original relative concentration of the first compound (C1) in the evaporation source mixture. One of ordinary skill in this field should realize that the concentration of each component in the mixture is expressed as relative percentage. The concentration of each component in the mixture can be measured by a suitable analytical methods well known to those skilled in the art. Examples of such methods are high pressure liquid chromatography (HPLC) and nuclear magnetic resonance spectroscopy (NMR). The percentage was calculated by dividing the integration area under the HPLC trace of each component by the total integration area. HPLC can use different detectors such as UV-vis, photo diode array detector, refractive index detector, fluorescence detector, and light scattering detector. Due to different materials properties, each component in the mixture may respond differently. Therefore, the measured concentration may differ from their real concentration in the mixture, however the relative ratio value of  $(C1-C2)/C1$  is independent of these variables as long as the experimental condition keeps consistent, for example, all concentrations should be calculated under the exact same HPLC parameters for each component. It is sometimes preferred to select a measurement condition that gives calculated concentration close to the real concentration. However, it is not necessary. It is important to select a detecting condition that accurately

detects each component. For example, fluorescence detector should not be used if one of the components does not fluoresce.

In one embodiment, the first compound has evaporation temperature T1 of 200 to 350° C. and the second compound has evaporation temperature T2 of 200 to 350° C.

In one embodiment, the first compound has a vapor pressure of P1 at T1 at 1 atm, and the second compound has a vapor pressure of P2 at T2 at 1 atm. The ratio of P1/P2 is desirably within the range of 0.90 to 1.10.

The first compound has a first mass loss rate and the second compound has a second mass loss rate, wherein the ratio between the first mass loss rate and the second mass loss rate is desirably within the range of 0.90 to 1.10. Preferably, the ratio between the first mass loss rate and the second mass loss rate is within the range of 0.95 to 1.05. More preferably, the ratio between the first mass loss rate and the second mass loss rate is within the range of 0.97 to 1.03.

The phosphorescent emitter component in the composition is capable of emitting light from a triplet excited state to a ground singlet state at room temperature. In one embodiment of the composition, the first compound is a metal coordination complex having a metal-carbon bond. The metal in the metal-carbon bond can be selected from the group consisting of Ir, Rh, Re, Ru, Os, Pt, Au, and Cu. In another embodiment, the metal is Ir (iridium). In another embodiment, the metal is Pt (platinum).

In one embodiment of the composition, the second compound is also capable of functioning as a phosphorescent emitter in an OLED at room temperature.

In another embodiment, the second compound is capable of functioning as a host in the EML of an OLED at room temperature. In one embodiment, the host is a hole transporting host. In another embodiment, the host is an electron transporting host.

According to an aspect of the present disclosure, the lowest triplet energy TE1 of the first compound is lower than that of the second compound. Triplet energy is determined by phosphorescence in an organic solvent glass at 77° K.

In one embodiment of the composition, the second compound comprises at least one chemical group selected from the group consisting of triphenylene, carbazole, dibenzothiophene, dibenzofuran, dibenzoselenophene, aza-triphenylene, aza-carbazole, aza-dibenzothiophene, aza-dibenzofuran, and aza-dibenzoselenophen.

In one embodiment of the composition, the first compound and the second compound each has a purity in excess of 99% as determined by HPLC.

According to another aspect, the mixture in the composition further comprises a third compound. The third compound has a different chemical structure than the first compound and the second compound, wherein the third compound has an evaporation temperature T3 of 150 to 350° C.; and wherein the absolute value of T1-T3 is less than 20° C.; Preferably, the absolute value of T1-T3 is less than 10° C., and more preferably less than 5° C.

In one embodiment, the composition is in a liquid form at a temperature less than T1 (the evaporation temperature of the first compound) and T2 (the evaporation temperature of the second compound).

In one embodiment of the composition, the first compound has the formula of

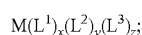

wherein L<sup>1</sup>, L<sup>2</sup> and L<sup>3</sup> can be the same or different; wherein x is 1, 2, or 3;

wherein y is 0, 1, or 2,

wherein z is 0, 1, or 2;

wherein x+y+z is the oxidation state of the metal M;

wherein L<sup>1</sup>, L<sup>2</sup>, and L<sup>3</sup> are independently selected from the group consisting of:

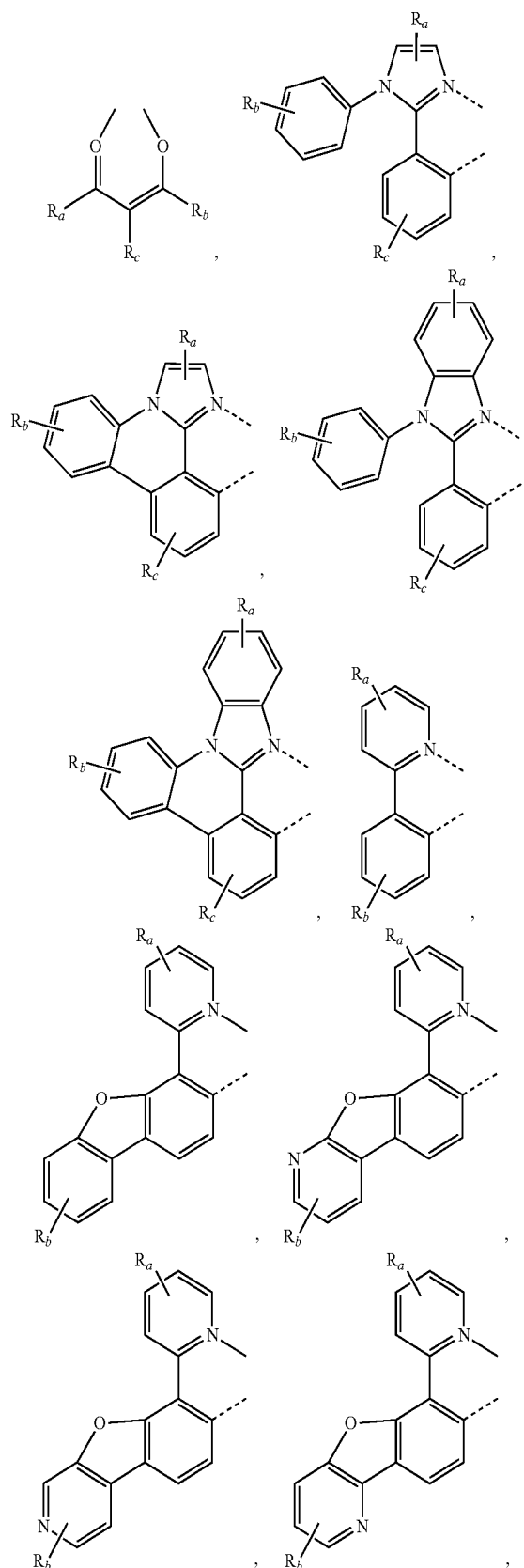

19

-continued

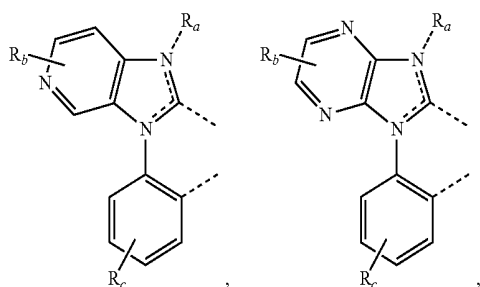
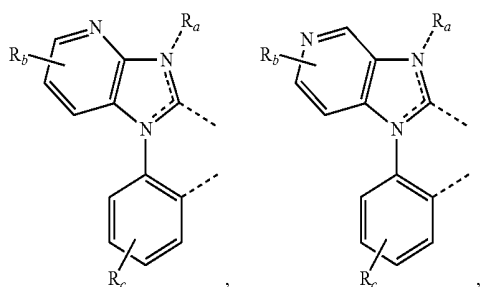
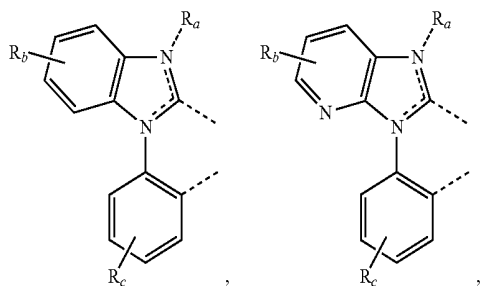
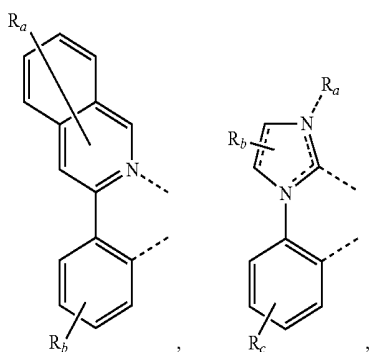
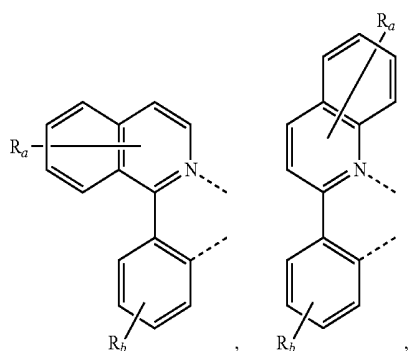

20

-continued

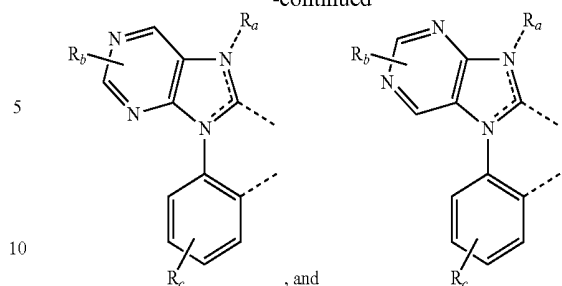

15

wherein  $R_a$ ,  $R_b$ ,  $R_c$ , and  $R_d$  may represent mono, di, tri, or tetra substitution, or no substitution;

20 wherein  $R_a$ ,  $R_b$ ,  $R_c$ , and  $R_d$  are independently selected from the group consisting of hydrogen, deuterium, halogen, alkyl, cycloalkyl, heteroalkyl, arylalkyl, alkoxy, aryloxy, amino, silyl, alkenyl, cycloalkenyl, heteroalkenyl, alkynyl, aryl, heteroaryl, acyl, carbonyl, carboxylic acid, ester, nitrile, isonitrile, sulfanyl, sulfinyl, sulfonyl, phosphino, and combinations thereof; and

25 wherein two adjacent substituents  $R_a$ ,  $R_b$ ,  $R_c$ , and  $R_d$  are optionally joined to form a fused ring or form a multidentate ligand.

30 According to another embodiment, where the first compound has the formula of  $M(L^1)_x(L^2)_y(L^3)_z$  as defined above, the first compound has the formula of  $Ir(L^1)_2(L^2)$ .

35 In one embodiment, where the first compound has the formula of  $Ir(L^1)_2(L^2)$ ,  $L^2$  has the formula:

40

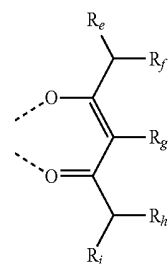

45

50

55 wherein  $R_e$ ,  $R_f$ ,  $R_h$ , and  $R_i$  are independently selected from group consisting of alkyl, cycloalkyl, aryl, and heteroaryl, wherein at least one of  $R_e$ ,  $R_f$ ,  $R_h$ , and  $R_i$  has at least two carbon atoms;

60 wherein  $R_g$  is selected from group consisting of hydrogen, deuterium, halogen, alkyl, cycloalkyl, heteroalkyl, arylalkyl, alkoxy, aryloxy, amino, silyl, alkenyl, cycloalkenyl, heteroalkenyl, alkynyl, aryl, heteroaryl, acyl, carbonyl, carboxylic acid, ester, nitrile, isonitrile, sulfanyl, sulfinyl, sulfonyl, phosphino, and combinations thereof.

65 In one embodiment, where the first compound has the formula of  $Ir(L^1)_2(L^2)$ ,  $L^2$  has the formula selected from the group consisting of:

21

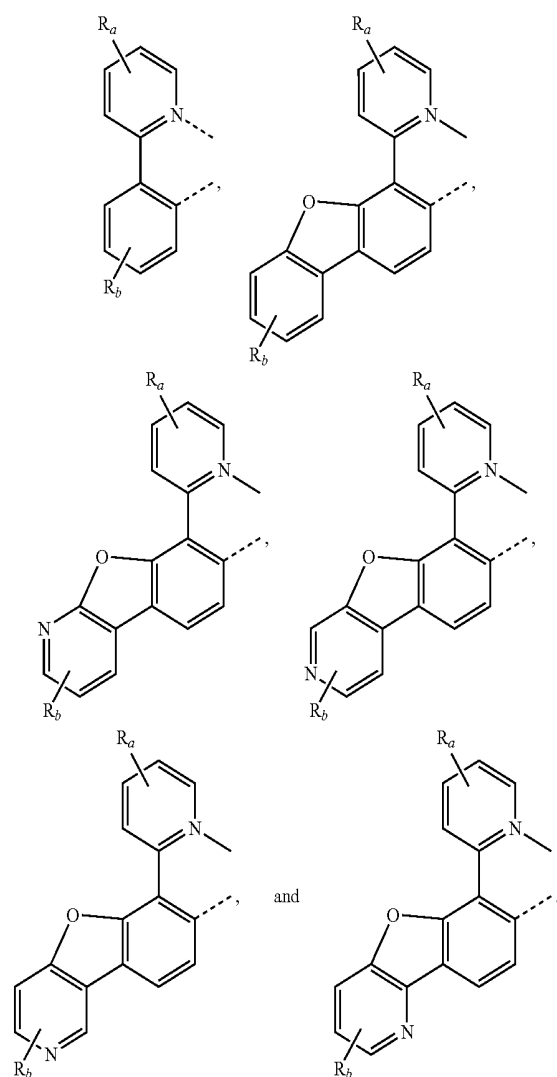

In another embodiment, where the first compound has the formula of  $M(L^1)_x(L^2)_y(L^3)_z$  as defined above, the first compound has the formula of  $Pt(L^1)_2$  or  $Pt(L^1)(L^2)$ .  $L^1$  can be connected to the other  $L^1$  or  $L^2$  to form a tetradentate ligand.

In one embodiment of the composition, the first compound has the Formula I:

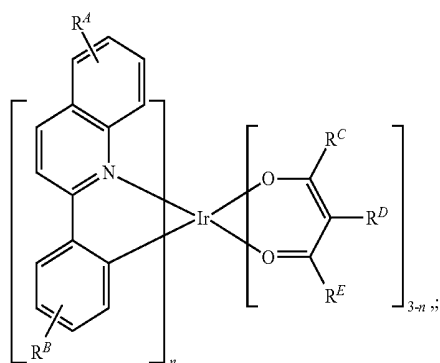

wherein  $R^A$  represents mono, di, tri, tetra, penta, hexa substitutions, or no substitution;

22

$R^B$  represents mono, di, tri, tetra substitutions, or no substitution;

$R^A$ ,  $R^B$ ,  $R^C$ ,  $R^D$ , and  $R^E$  are each independently selected from the group consisting of hydrogen, deuterium, halogen, alkyl, cycloalkyl, heteroalkyl, arylalkyl, alkoxy, aryloxy, amino, cyclic amino, silyl, alkenyl, cycloalkenyl, heteroalkenyl, alkynyl, aryl, heteroaryl, acyl, carbonyl, carboxylic acid, ether, ester, nitrile, isonitrile, sulfanyl, sulfinyl, sulfonyl, phosphino, and combinations thereof;

wherein  $n$  is 1 or 2;

wherein the second compound has the Formula II:

Formula II

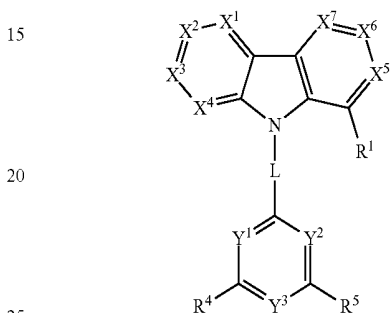

wherein  $R^1$ ,  $R^4$ , and  $R^5$  are independently selected from group consisting of hydrogen, deuterium, halogen, alkyl, cycloalkyl, heteroalkyl, arylalkyl, alkoxy, aryloxy, amino, cyclic amino, silyl, alkenyl, cycloalkenyl, heteroalkenyl, alkynyl, aryl, heteroaryl, acyl, carbonyl, carboxylic acid, ether, ester, nitrile, isonitrile, sulfanyl, sulfinyl, sulfonyl, phosphino, and combinations thereof; wherein  $L$  is selected from the group consisting of a direct bond, aryl, substituted aryl, heteroaryl, substituted heteroaryl, and combinations thereof;

wherein  $X^1$ ,  $X^2$ ,  $X^3$ ,  $X^4$ ,  $X^5$ ,  $X^6$ ,  $X^7$ ,  $Y^1$ ,  $Y^2$ , and  $Y^3$  are each independently selected from the group consisting of CR and N;

wherein at least two of  $Y^1$ ,  $Y^2$ , and  $Y^3$  are N; and

wherein each R can be same or different, and is independently selected from the group consisting of hydrogen, deuterium, halogen, alkyl, cycloalkyl, heteroalkyl, arylalkyl, alkoxy, aryloxy, amino, cyclic amino, silyl, alkenyl, cycloalkenyl, heteroalkenyl, alkynyl, aryl, heteroaryl, acyl, carbonyl, carboxylic acid, ether, ester, nitrile, isonitrile, sulfanyl, sulfinyl, sulfonyl, phosphino, and combinations thereof.

In another embodiment,  $R^1$ ,  $R^4$ , and  $R^5$  in Formula II are independently selected from group consisting of non-fused aryl, non-fused heteroaryl, and combinations thereof; wherein  $L$  is selected from the group consisting of a direct bond, non-fused aryl, non-fused heteroaryl, and combinations thereof; and wherein each of R is independently selected from the group consisting of hydrogen, deuterium, non-fused aryl, non-fused heteroaryl and combinations thereof.

In another embodiment,  $R^1$  in Formula II is selected from the group consisting of phenyl, biphenyl, terphenyl, tetraphenyl, pentaphenyl, pyridine, phenyl pyridine and pyridyl phenyl.

In another embodiment,  $L$  in Formula II is selected from the group consisting of phenyl, pyridyl, biphenyl, terphenyl and a direct bond.

In another embodiment,  $R^4$  and  $R^5$  in Formula II are each independently selected from the group consisting of phenyl, pyridyl, biphenyl, and terphenyl.

23

In another embodiment of the composition, where the first compound has the structure according to Formula I as defined above, the second compound has a structure according to Formula III:

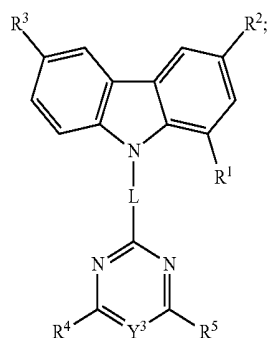

Formula III

wherein  $R^2$  and  $R^3$  are each independently selected from the group consisting of hydrogen, deuterium, halogen, alkyl, cycloalkyl, heteroalkyl, arylalkyl, alkoxy, aryloxy, amino, cyclic amino, silyl, alkenyl, cycloalkenyl, heteroalkenyl, alkynyl, aryl, heteroaryl, acyl, carbonyl, carboxylic acid, ether, ester, nitrile, sulfanyl, sulfinyl, sulfonyl, phosphino, and combinations thereof.

In one embodiment,  $R^2$  and  $R^3$  of Formula III are each independently selected from the group consisting of hydrogen, deuterium, non-fused aryl, non-fused heteroaryl and combinations thereof.

In one embodiment, where the second compound has the structure of Formula III, the second compound can have a structure selected from the group consisting of:

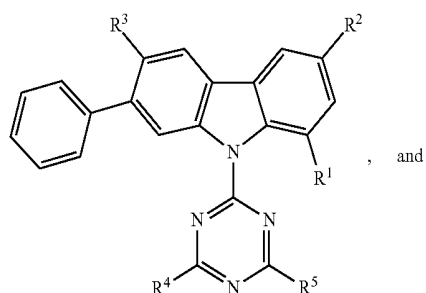
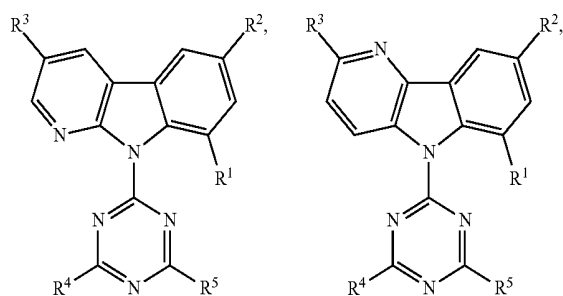

24

-continued

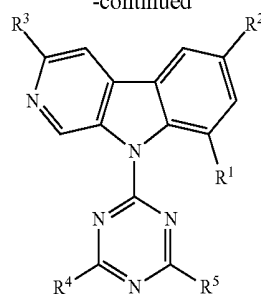

5

10

15

20

In one embodiment of the composition where the first compound has the structure of Formula I,  $n$  is 1. In another embodiment,  $R^A$ ,  $R^B$ ,  $R^C$ ,  $R^D$ , and  $R^E$  are each independently selected from the group consisting of hydrogen, deuterium, alkyl, cycloalkyl, and combinations thereof. In another embodiment, at least one of  $R^C$  and  $R^E$  contains a branched alkyl moiety with branching at a position further than the  $\alpha$  position to the carbonyl group. In another embodiment,  $R^D$  is hydrogen.

In one embodiment of the composition where the first compound has the structure of Formula I, at least one of  $R^C$  and  $R^E$  has the following structure:

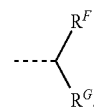

25

30

wherein  $R^F$  and  $R^G$  are independently selected from group consisting of alkyl and cycloalkyl; and wherein at least one of  $R^F$  and  $R^G$  has at least two C.

35

In one embodiment of the composition where the second compound has the structure according to Formula II defined above, the first compound has a structure according to Formula IV:

40

Formula IV

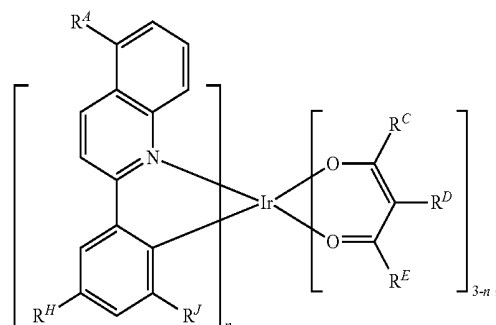

45

50

55

wherein  $R^H$  and  $R^J$  are each independently selected from the group consisting of hydrogen, deuterium, halogen, alkyl, cycloalkyl, heteroalkyl, arylalkyl, alkoxy, aryloxy, amino, cyclic amino, silyl, alkenyl, cycloalkenyl, heteroalkenyl, alkynyl, aryl, heteroaryl, acyl, carbonyl, carboxylic acid, ether, ester, nitrile, isonitrile, sulfanyl, sulfinyl, sulfonyl, phosphino, and combinations thereof.

60

In another embodiment of the composition where the first compound has a structure according to Formula IV as defined above,  $R^H$  and  $R^J$  are each independently selected from the group consisting of hydrogen, deuterium, alkyl, cycloalkyl, and combinations thereof.

65

25

In another embodiment of the composition where the first compound has a structure according to Formula IV as defined above,  $R^H$  and  $R^J$  are methyl.

In an embodiment of the composition where the second compound has a structure according to Formula II, the second compound can be selected from the group consisting of:

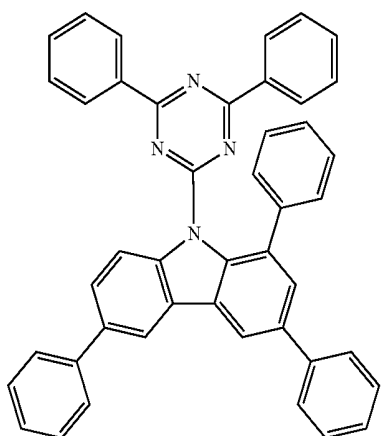
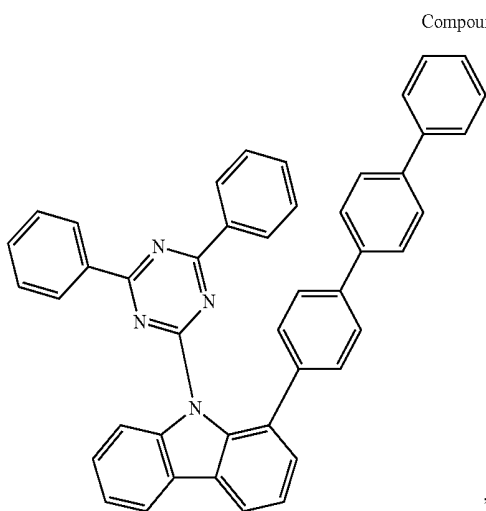
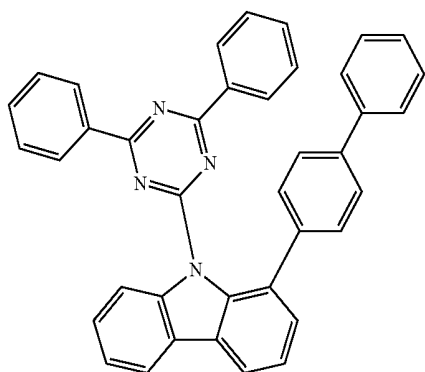

26

-continued

Compound H4

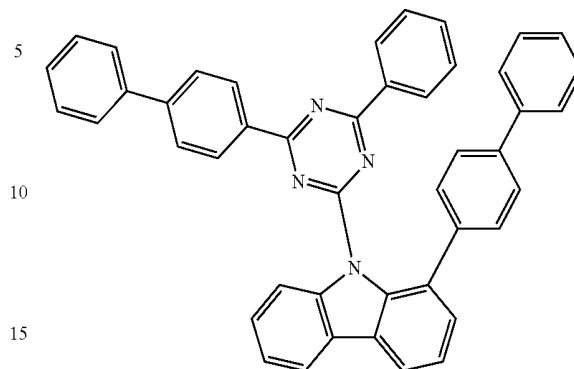

Compound H5

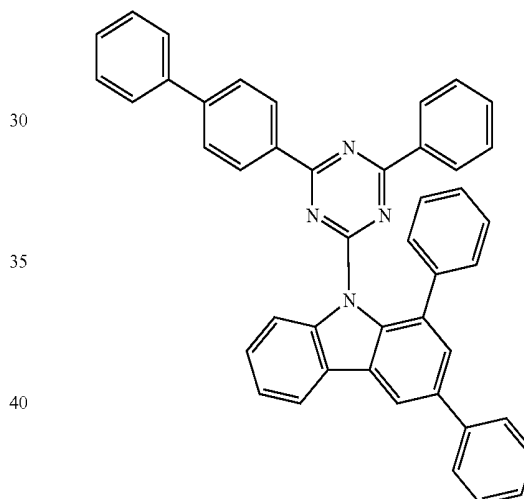

Compound H3 50

Compound H6

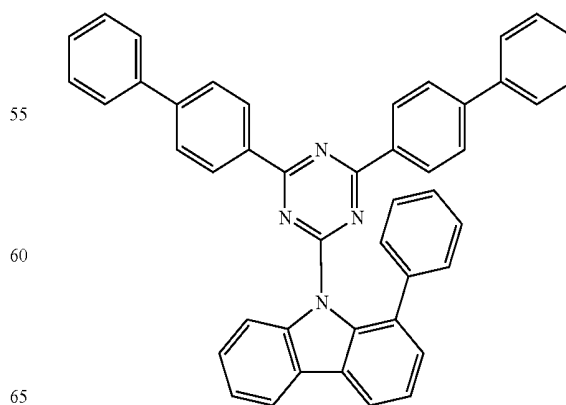

27  
-continued

Compound H7

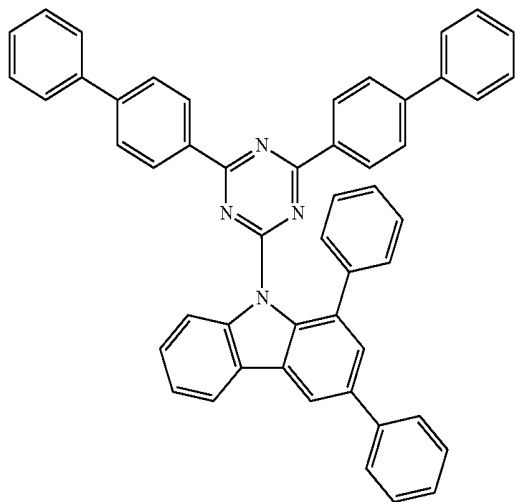

5

10

15

20

28  
-continued

Compound H10

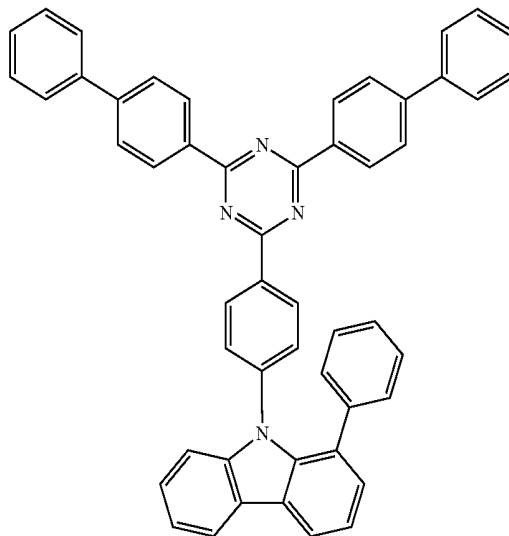

5

10

15

20

Compound H11

Compound H8

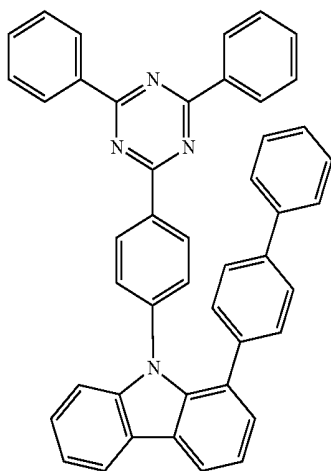

25

30

35

40

Compound H9

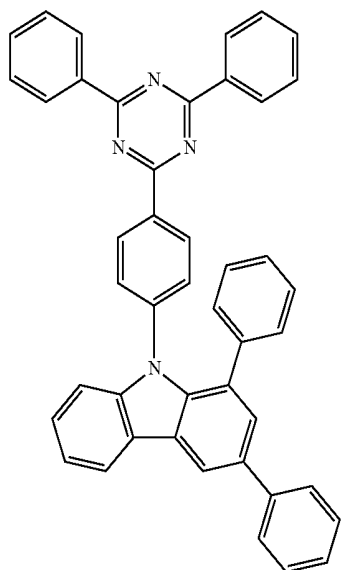

45

50

55

60

65

Compound H12

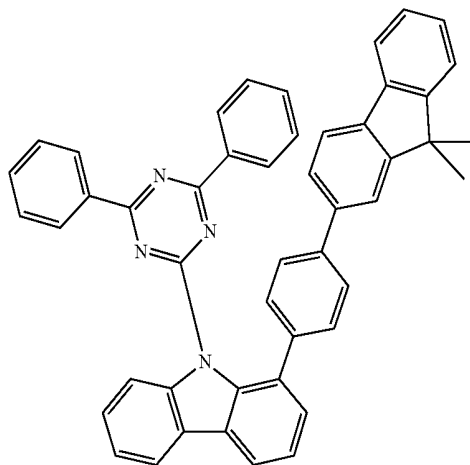

65

**29**  
-continued

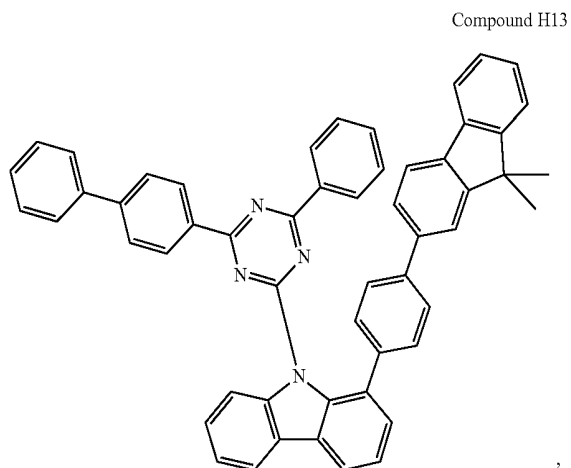

**30**  
-continued

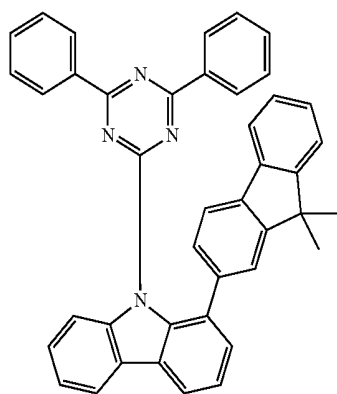
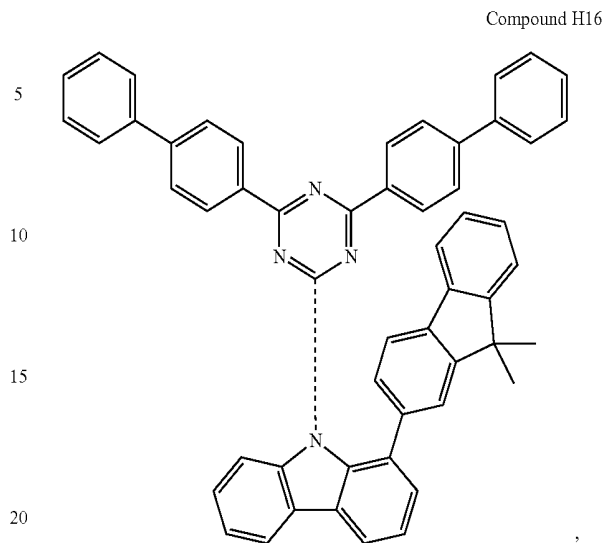

Compound H14

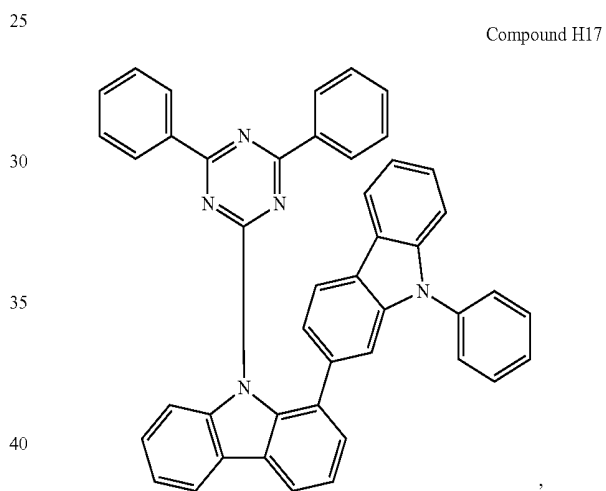

45

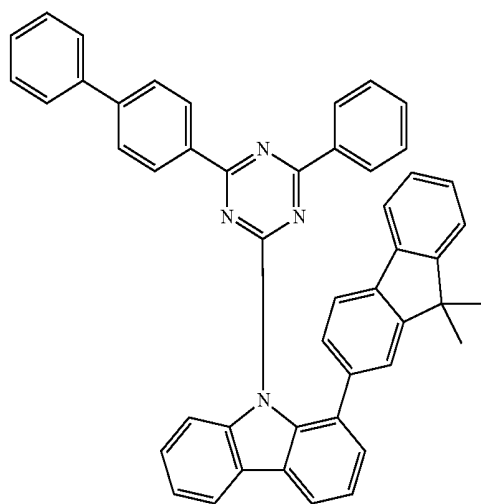

Compound H18

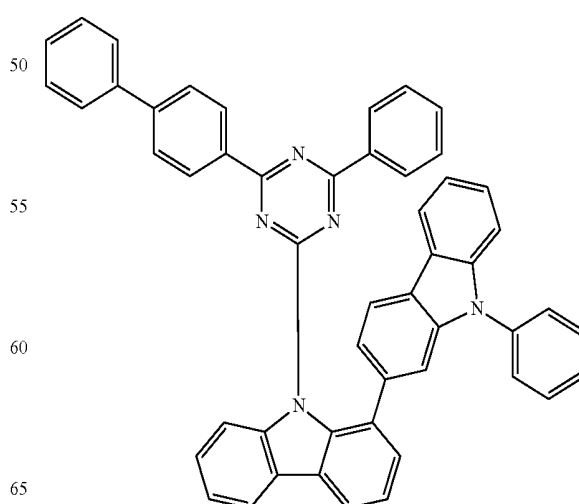

65

**31**  
-continued

Compound H19

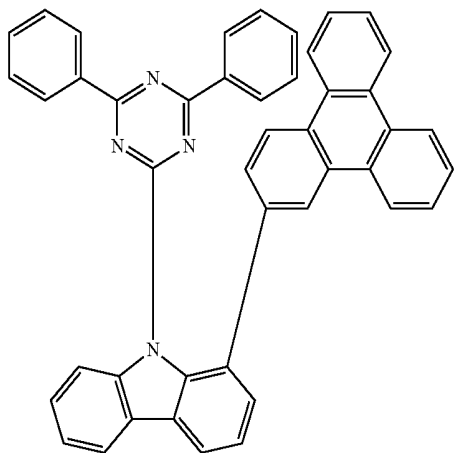

**32**  
-continued

Compound H22

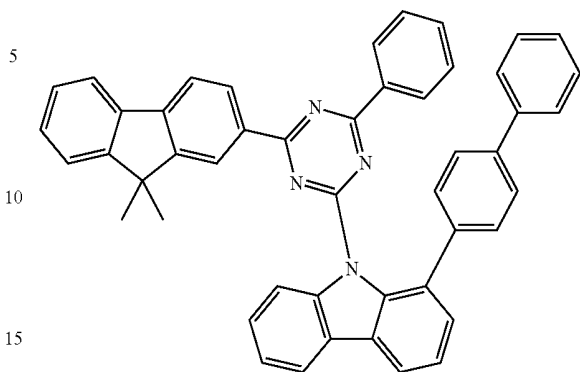

Compound H23

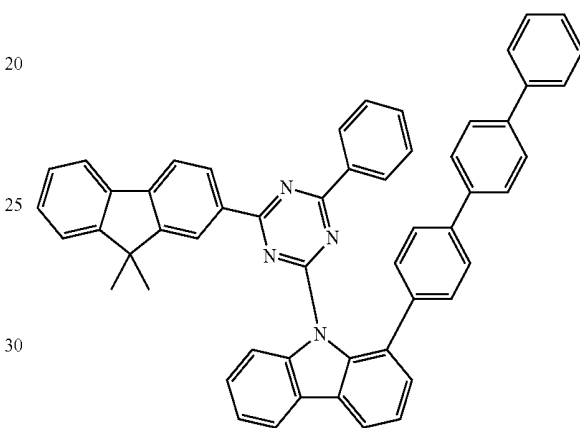

Compound H20

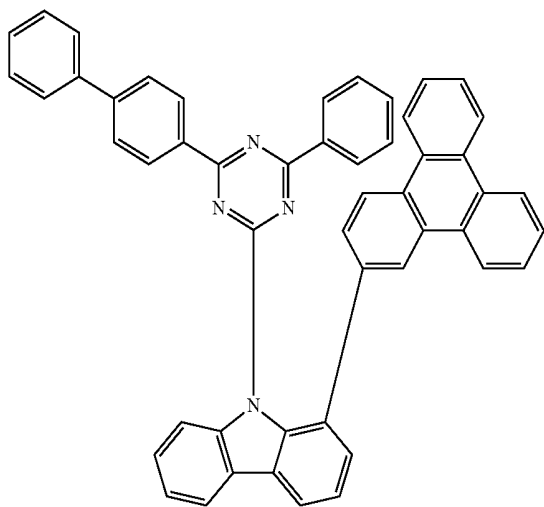

Compound H24

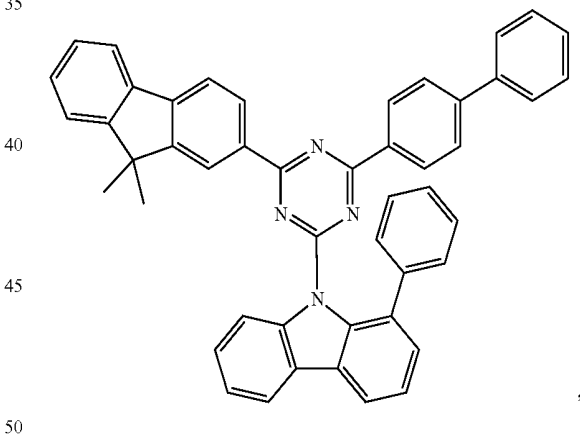

Compound H21

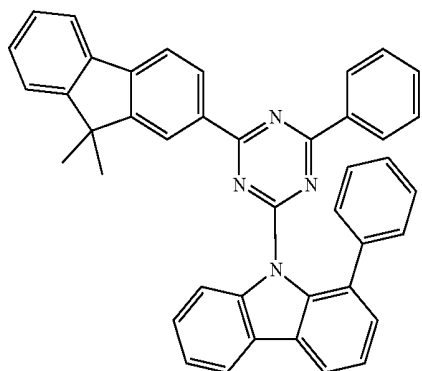

Compound H25

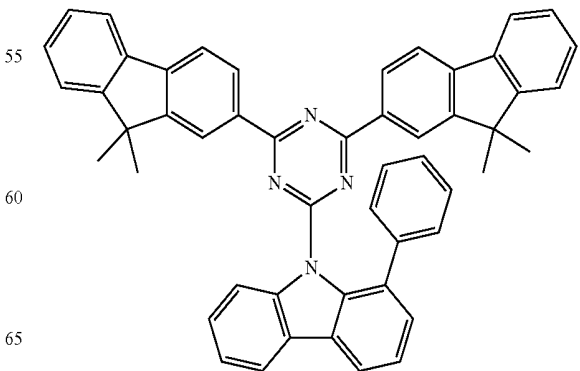

33

-continued

Compound H26

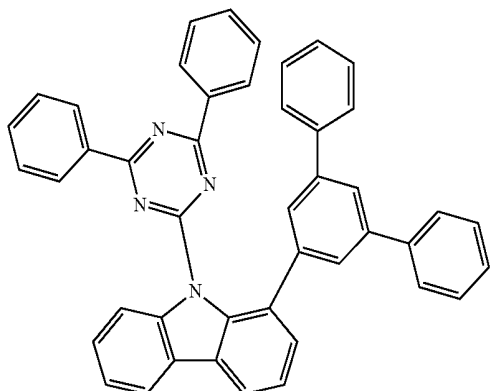

5

10

15

Compound H27

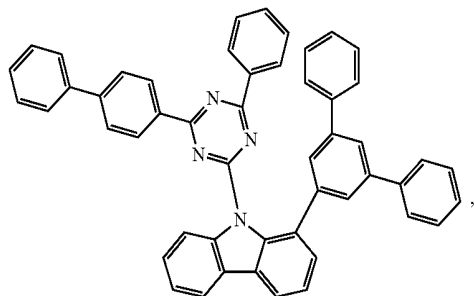

20

25

30

Compound H28

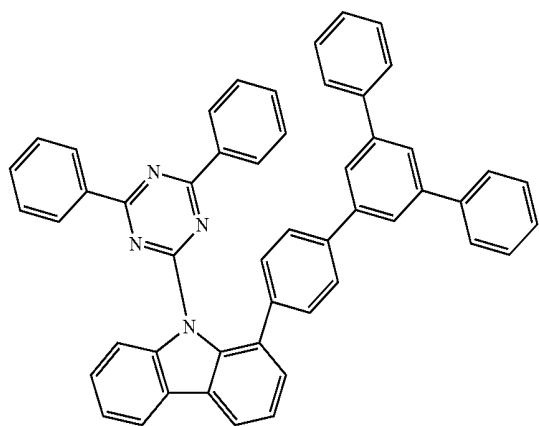

35

40

45

50

Compound H29

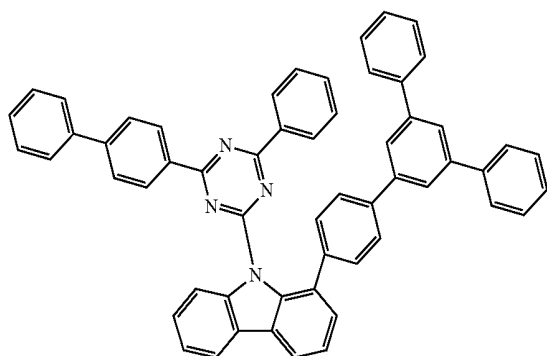

55

60

65

34

-continued

Compound H30

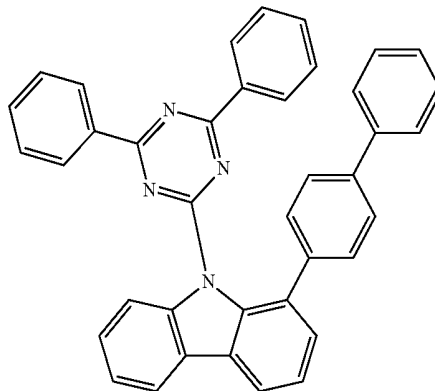

5

10

15

Compound H31

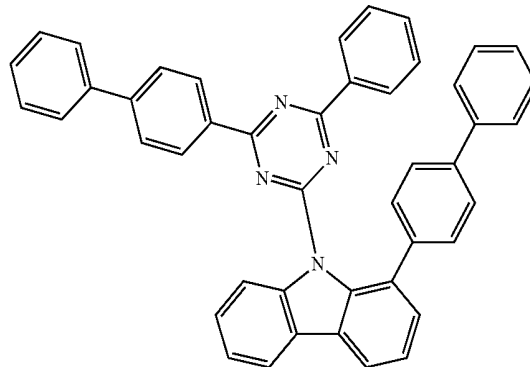

20

25

30

Compound H32

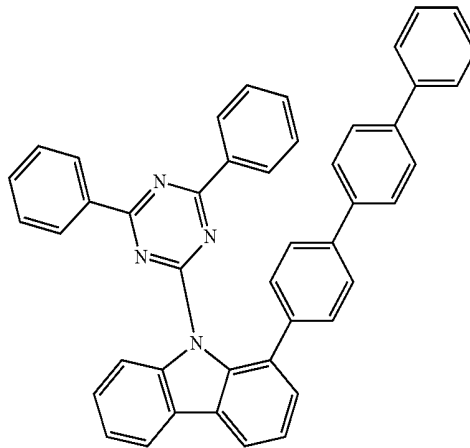

35

40

45

50

Compound H33

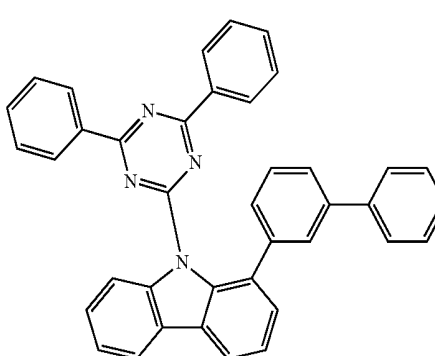

55

60

65

35

-continued

Compound H34

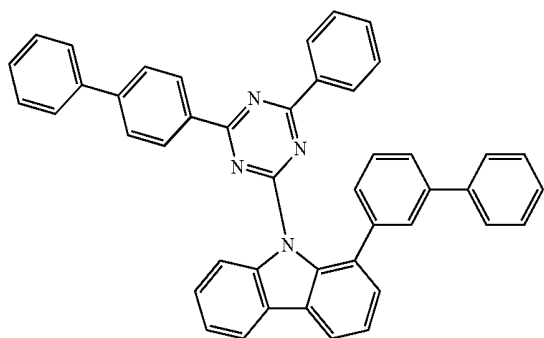

5  
10  
15

36

-continued

Compound H38

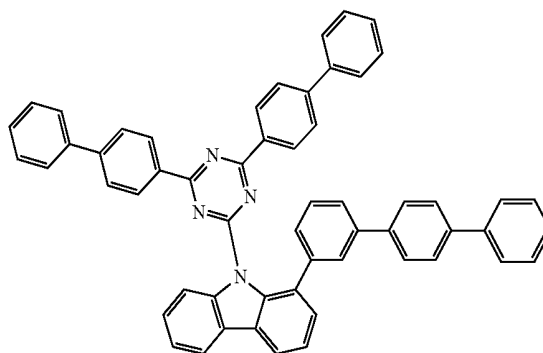

Compound H39

Compound H35

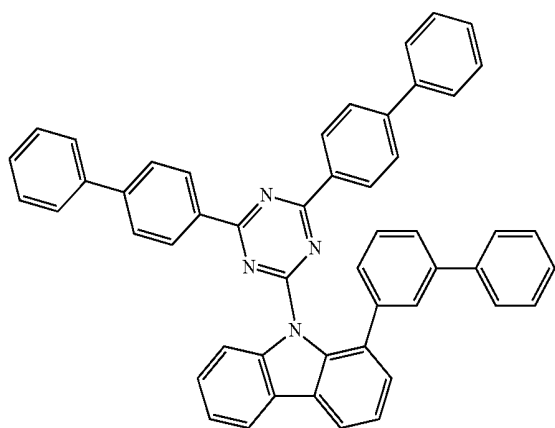

20  
25  
30

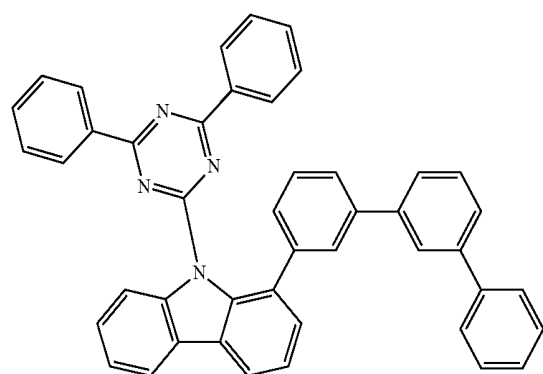

Compound H40

Compound H36

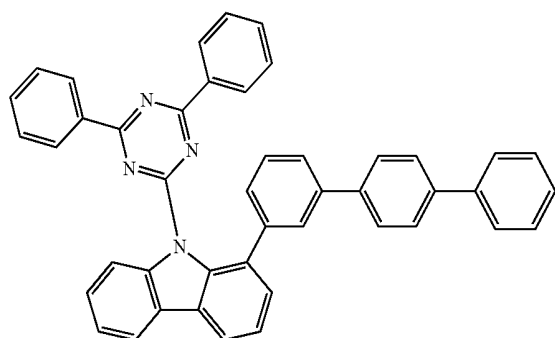

35  
40  
45  
50

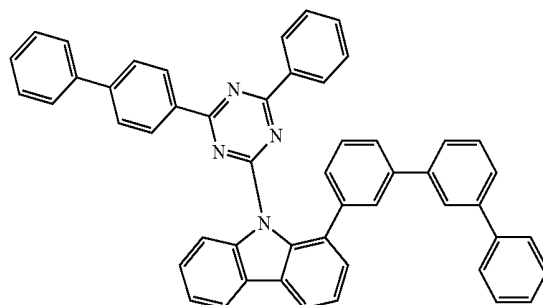

Compound H41

Compound H37

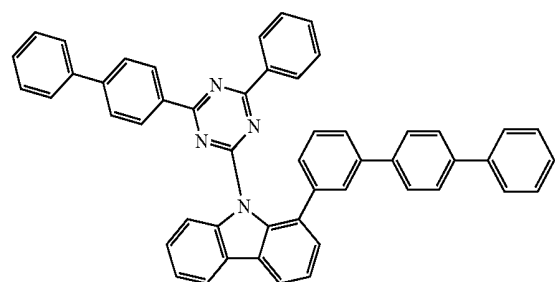

55  
60  
65

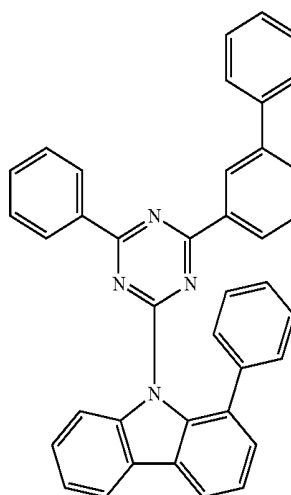

**37**  
-continued

Compound H42

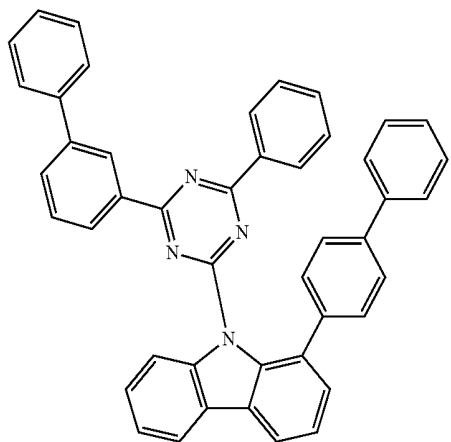

**38**  
-continued

Compound H45

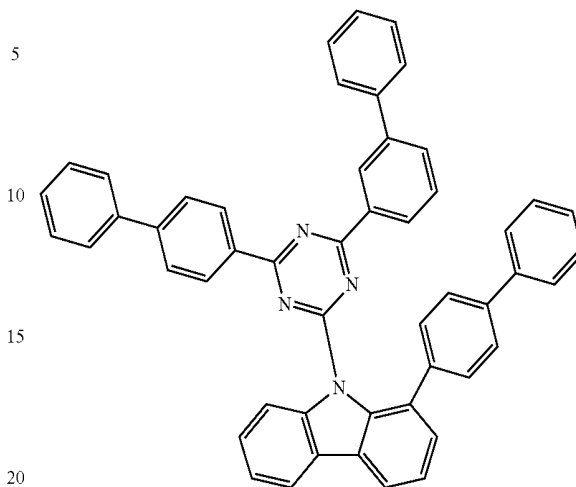

Compound H46

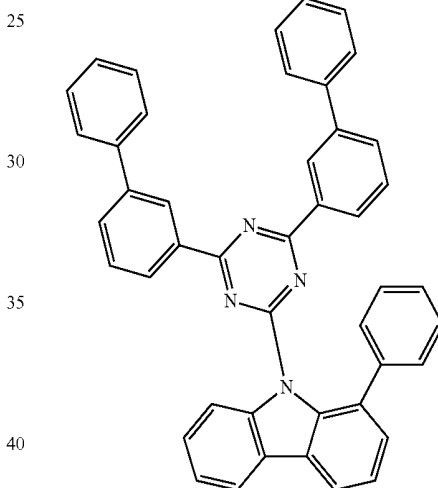

Compound H43

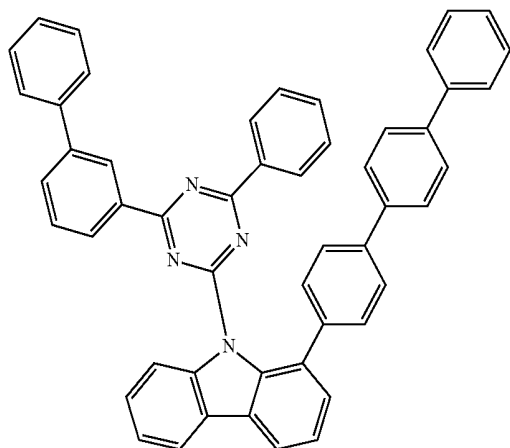

Compound H47

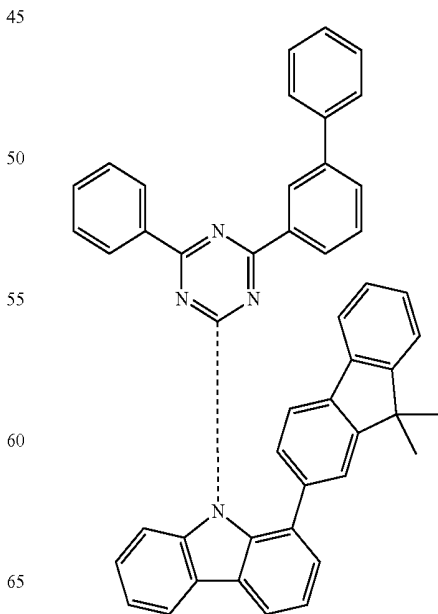

Compound H44

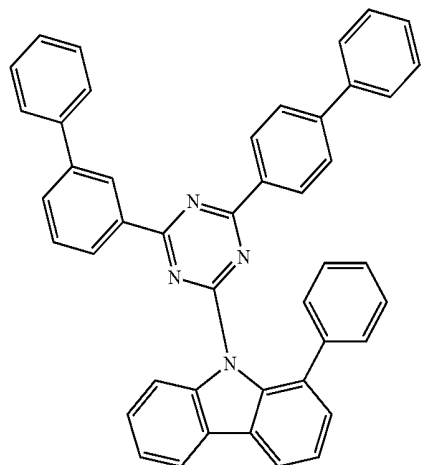

**39**  
-continued

Compound H48

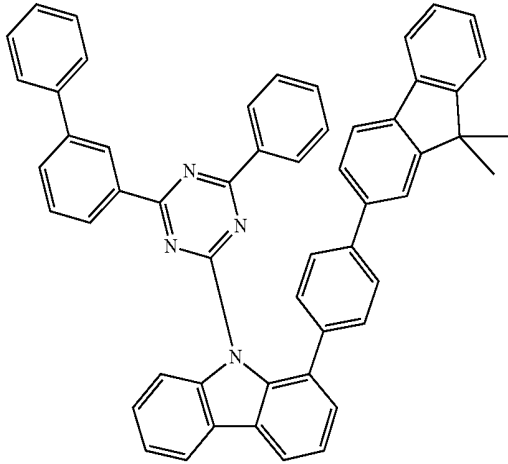

5

10

15

20

Compound H49

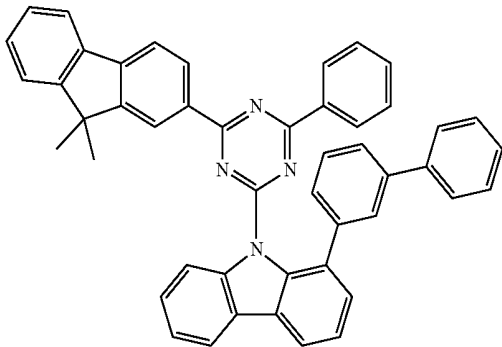

25

30

, and

Compound H50

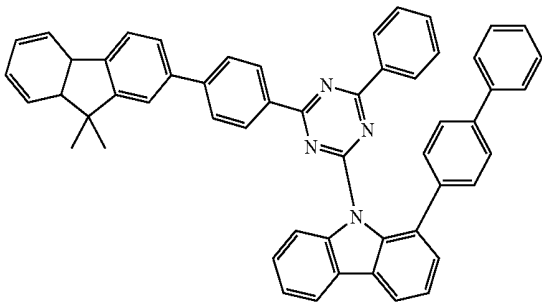

35

40

45

**40**  
-continued

Compound E2

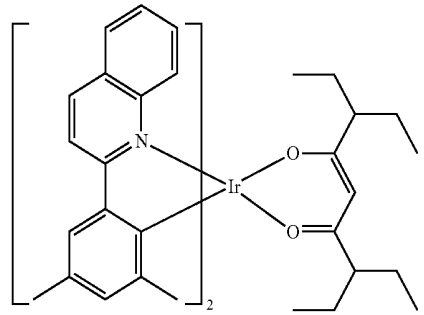

5

10

15

Compound E3

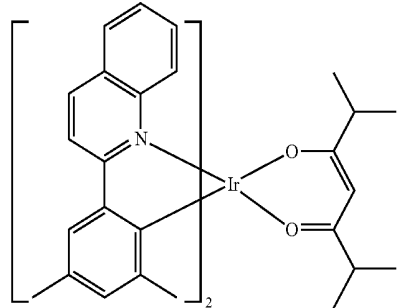

25

30

Compound E4

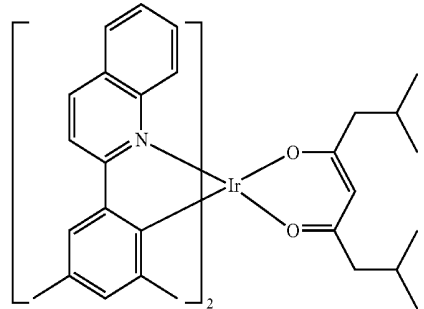

40

45

In another embodiment of the composition where the first compound has a structure according to Formula I as defined above, the first compound can be selected from the group consisting of:

Compound E1

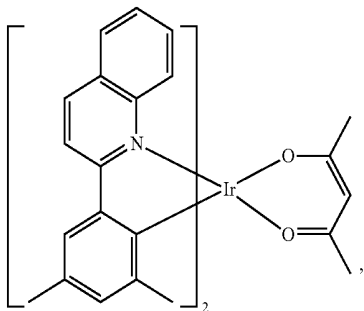

55

60

65

Compound E5

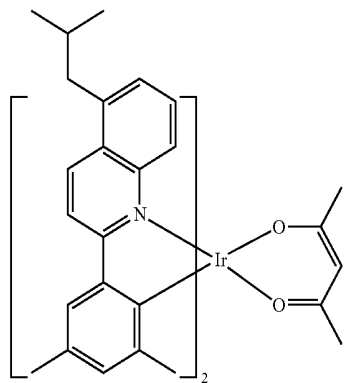

**41**

-continued

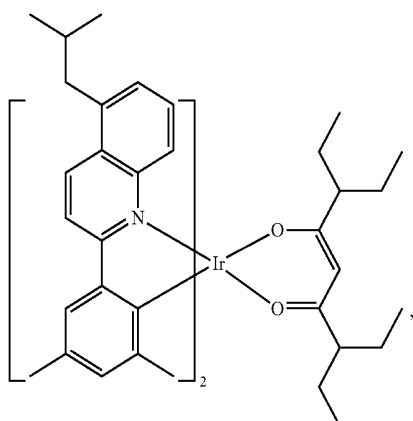

Compound E6

5

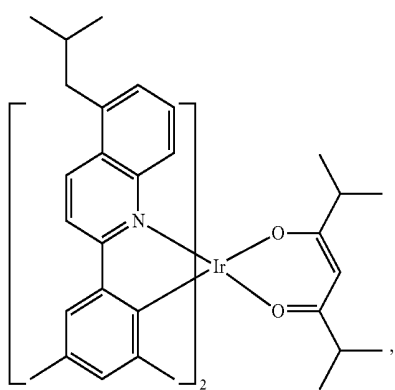

Compound E7

20

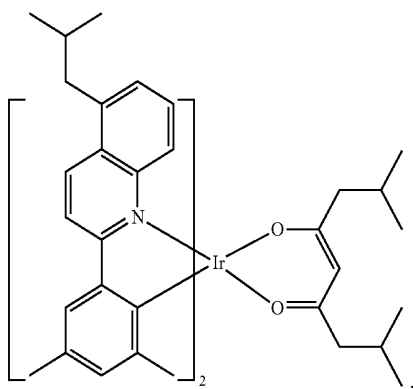

Compound E8

40

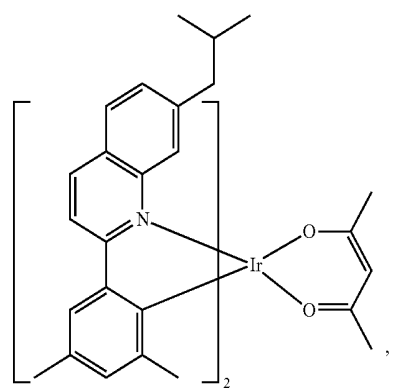

Compound E9

55

**42**

-continued

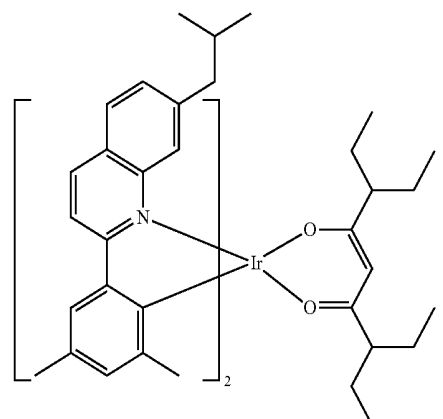

Compound E10

10

15

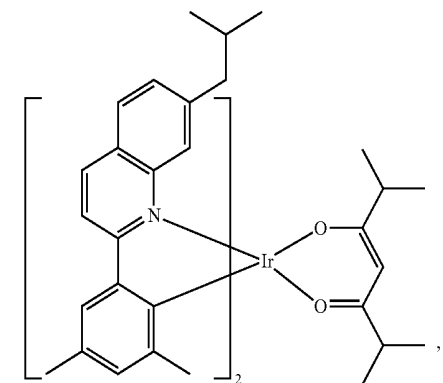

Compound E11

25

30

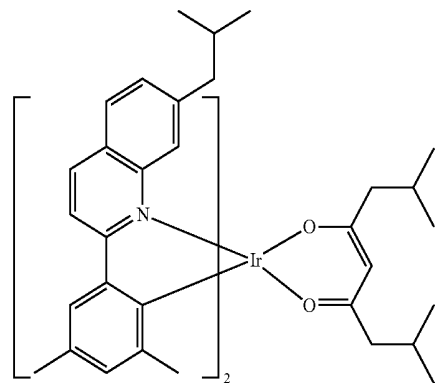

Compound E12

35

40

45

50

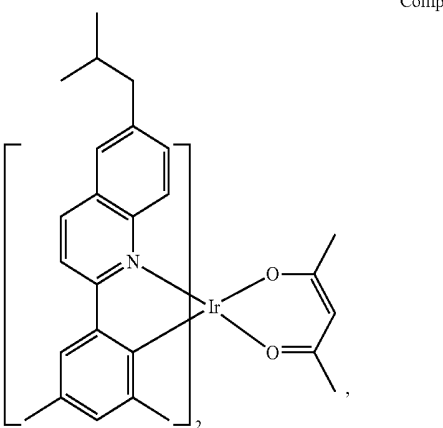

Compound E13

55

60

65

**43**  
-continued

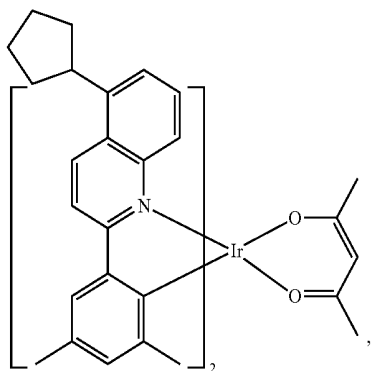
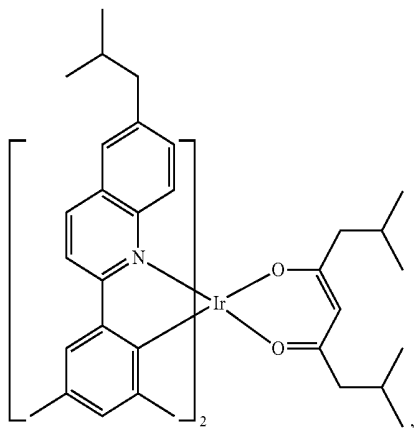
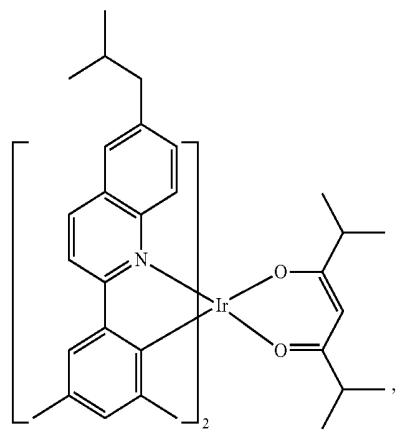
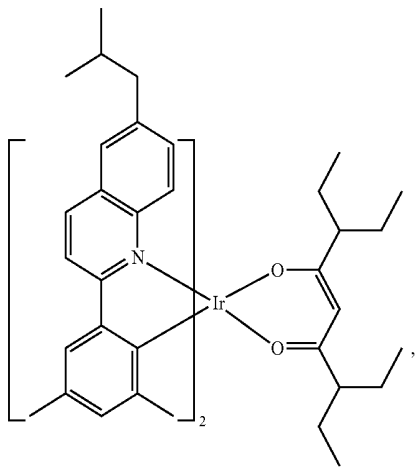

**44**  
-continued

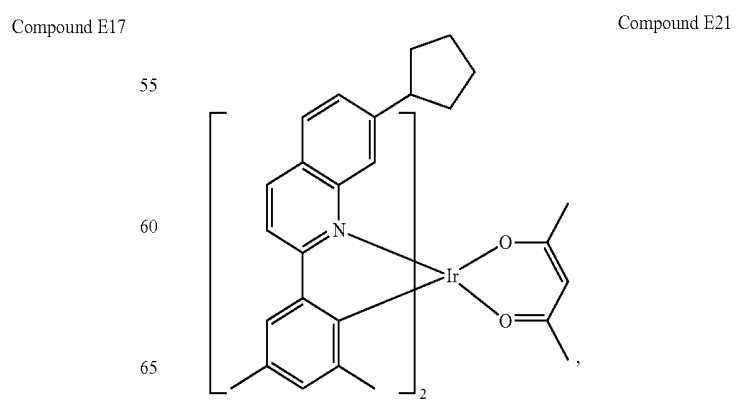
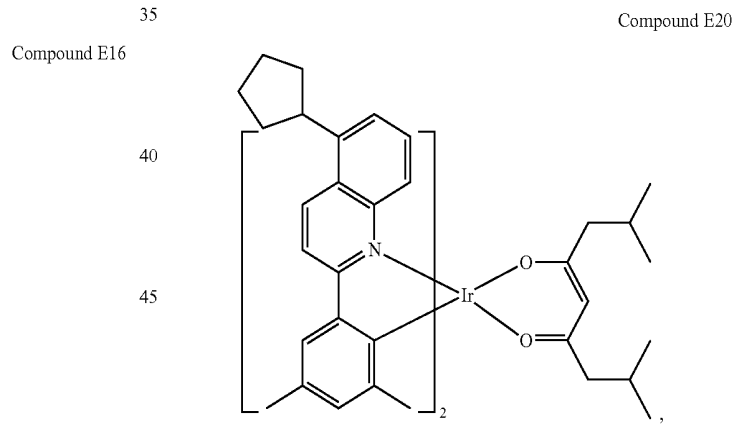
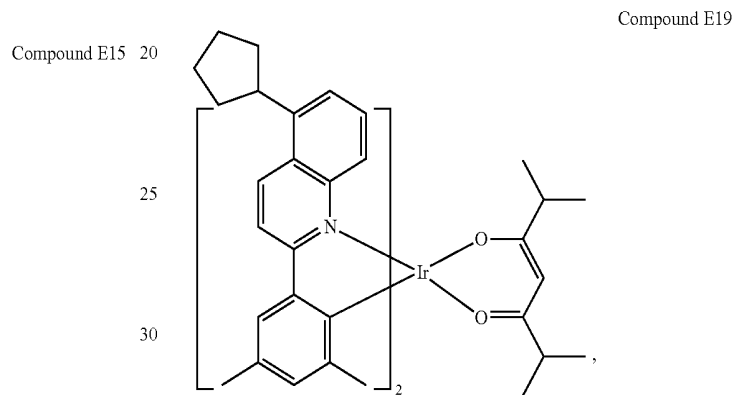
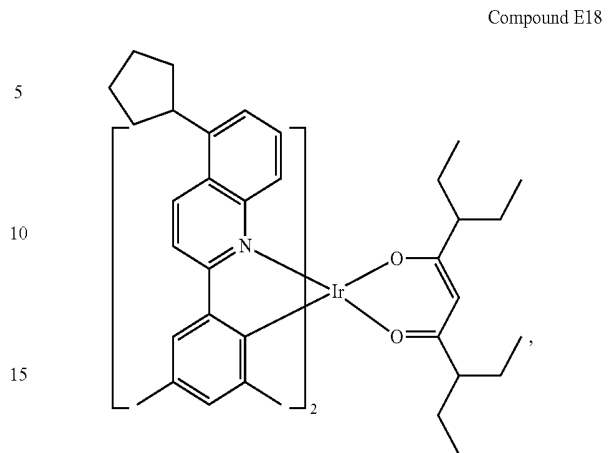

**45**  
-continued

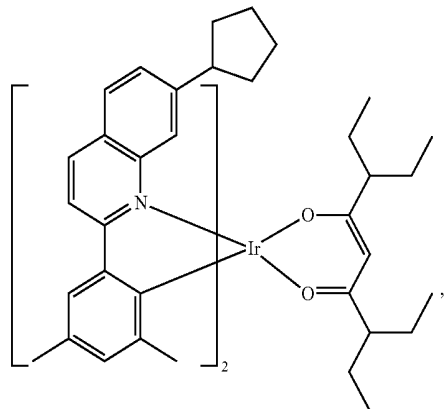

Compound E23

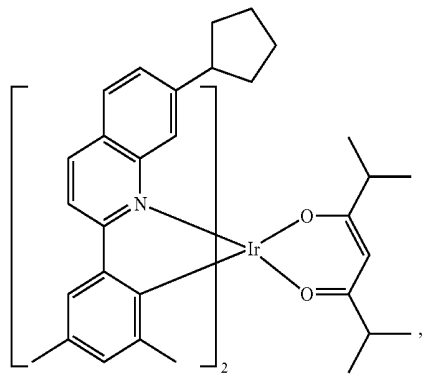

Compound E24

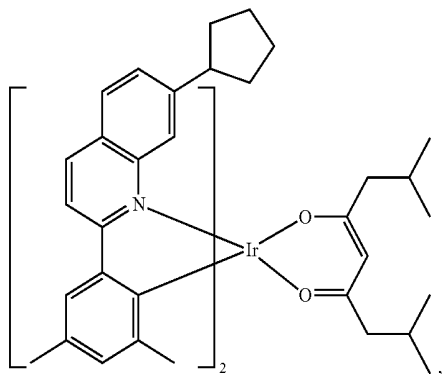

Compound E25

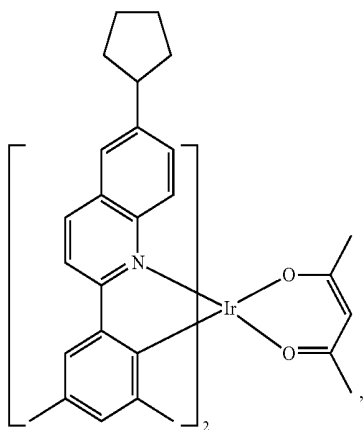

**46**  
-continued

5

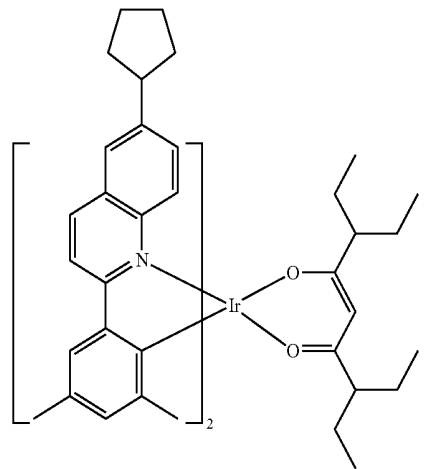

10

15

20

Compound E27

25

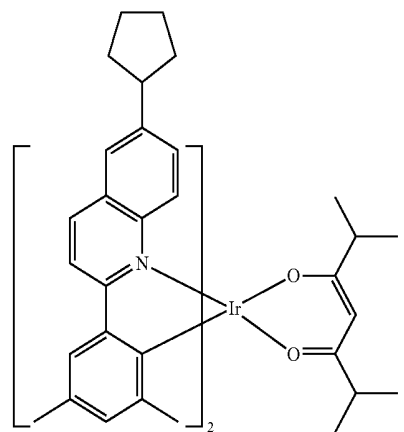

30

35

Compound E28

40

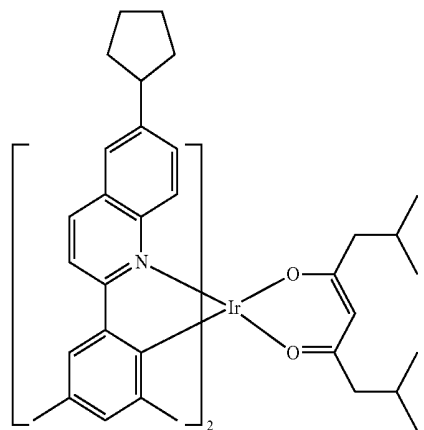

45

50

Compound E29

55

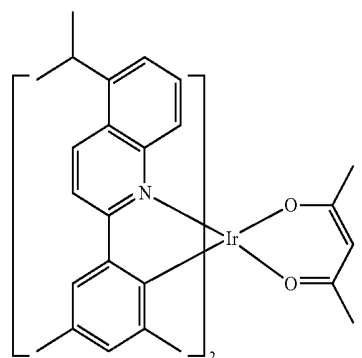

60

65

**47**  
-continued

**48**  
-continued

Compound E30

Compound E34

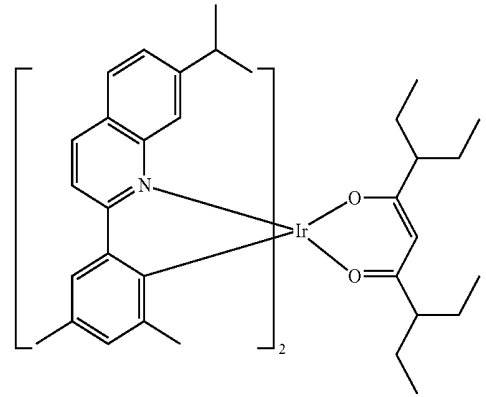
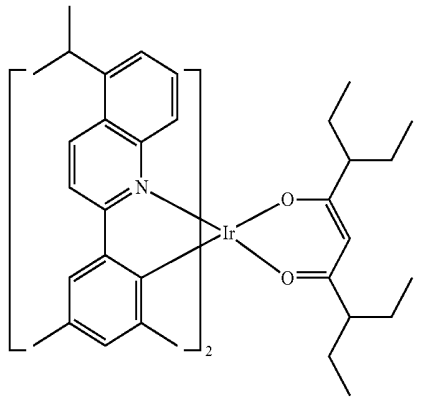

Compound E31

Compound E35

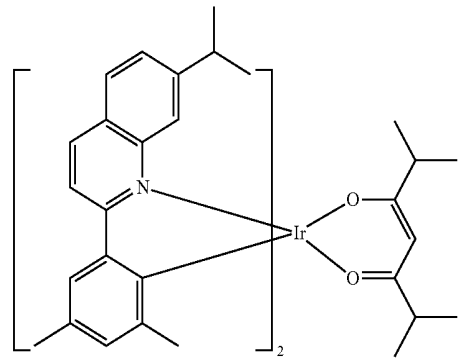
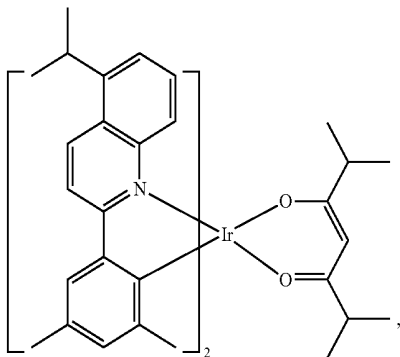

Compound E32

Compound E36

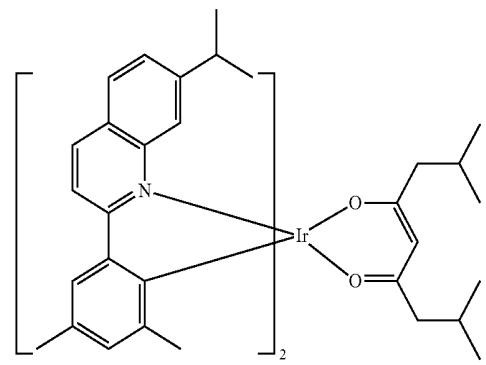
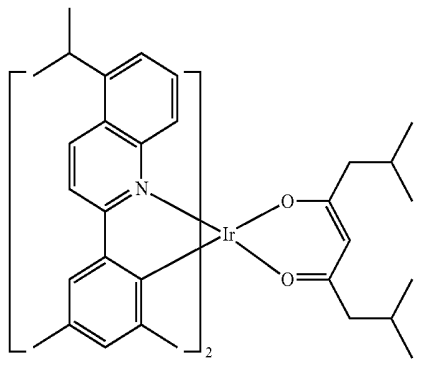

Compound E33

Compound E37

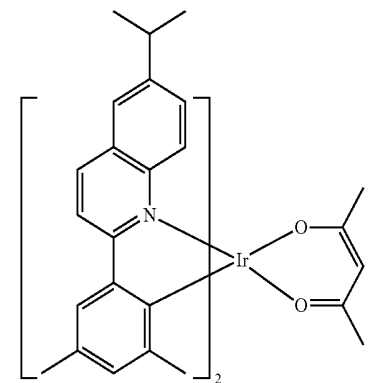
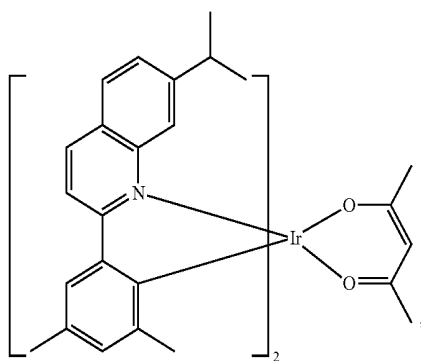

49

-continued

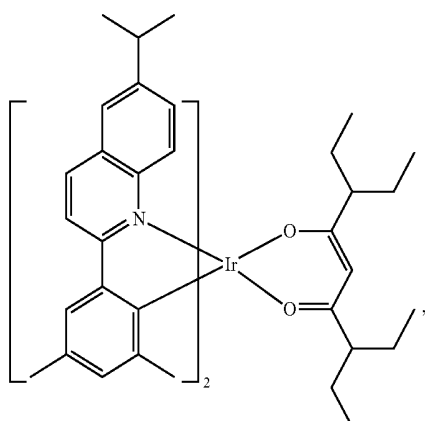

Compound E38

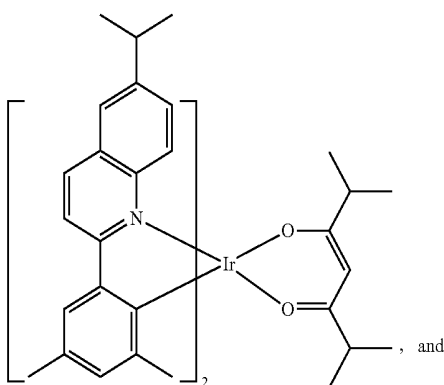

Compound E39

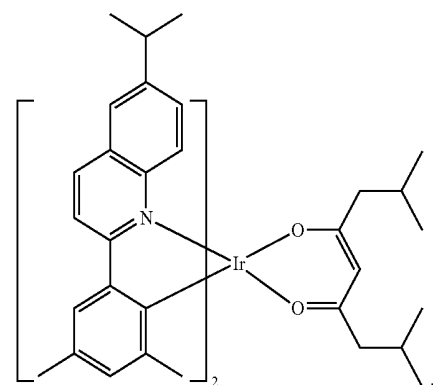

Compound E40

In another embodiment of the composition where the first compound has a structure according to Formula I and the second compound has a structure according to Formula II as defined above, the mixture of the first compound and the second compound is selected from the group consisting of: (Compound E5 and Compound H1), (Compound E1 and Compound H14), (Compound E4 and Compound H21), (Compound E9 and Compound H30), (Compound E17 and Compound H21), and (Compound E13 and Compound H33).

In another embodiment of the composition where the first compound has a structure according to Formula I and the second compound has a structure according to Formula II as defined above, the mixture of the first compound and the second compound is (Compound E5 and Compound H1).

In an embodiment of the composition comprising a mixture of a first compound and a second compound, wherein

50

the first compound has a difference chemical structure than the second compound, wherein the first compound is capable of functioning as a phosphorescent emitter in an OLED at room temperature, the first compound and the second compound each independently has the formula of  $\text{Ir}(\text{L}^1)_2(\text{L}^2)$ , wherein  $\text{L}^1$  has the formula:

10

15

20

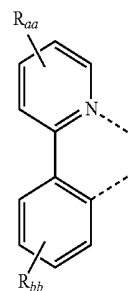

wherein  $\text{L}^2$  has the formula:

25

30

35

40

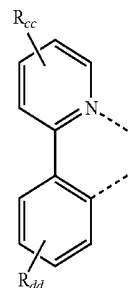

wherein  $\text{L}^1$  is different from  $\text{L}^2$ ;

wherein  $\text{R}_{aa}$ ,  $\text{R}_{bb}$ ,  $\text{R}_{cc}$ , and  $\text{R}_{dd}$  may represent mono, di, tri, or tetra substitution, or no substitution;

45

wherein  $\text{R}_{aa}$ ,  $\text{R}_{bb}$ ,  $\text{R}_{cc}$ , and  $\text{R}_{dd}$  are independently selected from the group consisting of hydrogen, deuterium, halogen, alkyl, cycloalkyl, heteroalkyl, arylalkyl, alkoxy, aryloxy, amino, silyl, alkenyl, cycloalkenyl, heteroalkenyl, alkynyl, aryl, heteroaryl, acyl, carbonyl, carboxylic acid, ester, nitrile, isonitrile, sulfanyl, sulfinyl, sulfonyl, phosphino, and combinations thereof;

50

55

wherein two adjacent substituents of  $\text{R}_{aa}$ ,  $\text{R}_{bb}$ ,  $\text{R}_{cc}$ , and  $\text{R}_{dd}$  are optionally joined to form a fused ring or form a multidentate ligand; and

wherein at least one of  $\text{R}_{cc}$  is a 5 or 6-membered carbocyclic or heterocyclic ring.

60

In one embodiment of the composition where the first compound and the second compound each independently has the formula of  $\text{Ir}(\text{L}^1)_2(\text{L}^2)$  as defined above, at least one of  $\text{R}_{cc}$  is benzene or pyridine.

65

In one embodiment of the composition where the first compound and the second compound each independently has the formula of  $\text{Ir}(\text{L}^1)_2(\text{L}^2)$  as defined above,  $\text{L}^1$  is selected from the group consisting of:

51

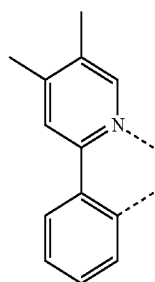
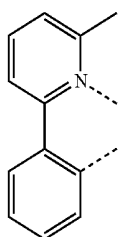
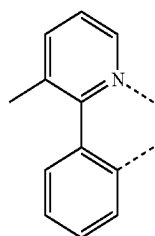
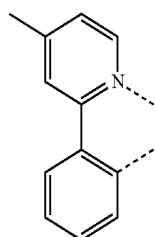
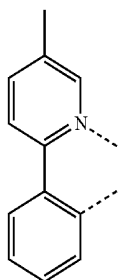
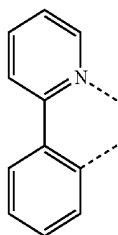

L1-1

5

L1-2

15

20

L1-3

25

30

L1-4

35

40

L1-5

45

50

55

L1-6

60

65

52

-continued

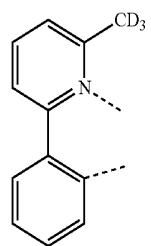
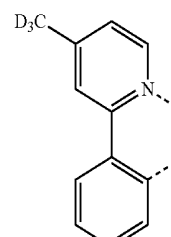
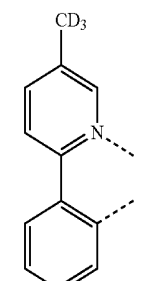
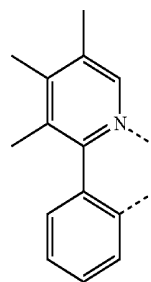
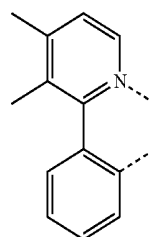
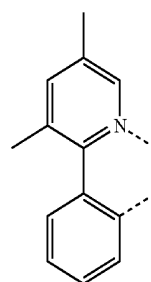

L1-7

L1-8

L1-9

L1-10

L1-11

L1-12

**53**

-continued

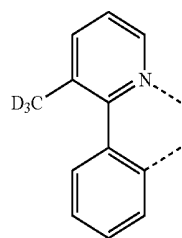

L1-13

5

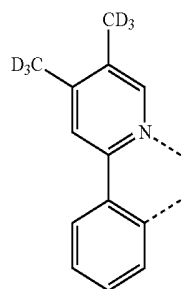

L1-14

15

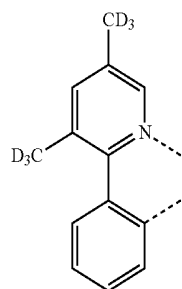

L1-15

25

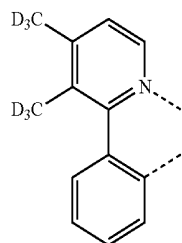

L1-16

35

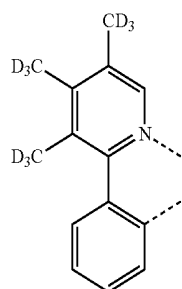

L1-17

45

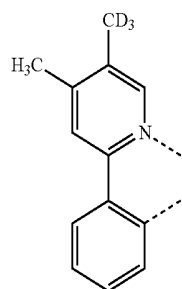

L1-18

55

60

65

**54**

-continued

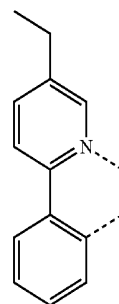

L1-19

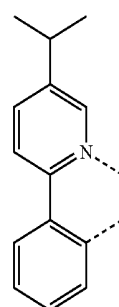

L1-20

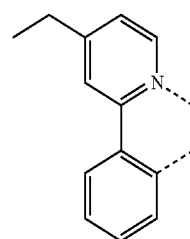

L1-21

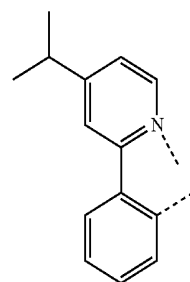

L1-22

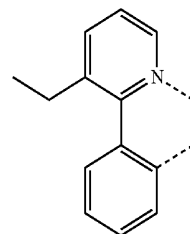

L1-23

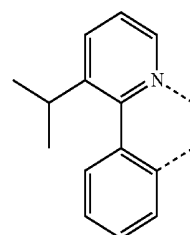

L1-24

**55**

-continued

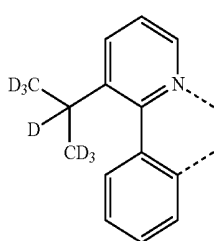
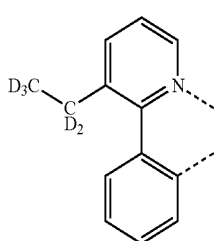
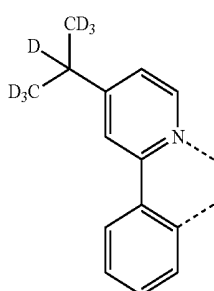
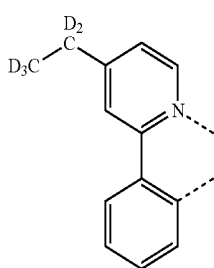
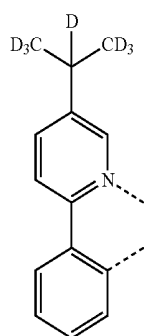
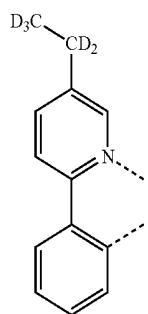

**56**

-continued

L1-25

5

10

L1-26

15

20

25

L1-27

30

35

L1-28

40

45

L1-29

50

55

L1-30

60

65

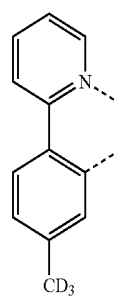
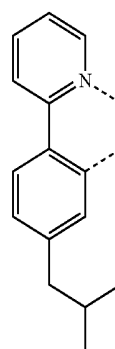
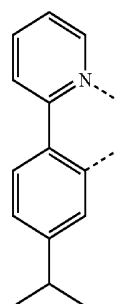
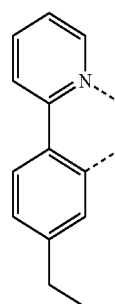
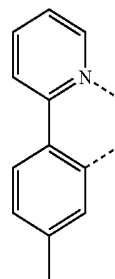

L1-31

L1-32

L1-33

L1-34

L1-35

57

-continued

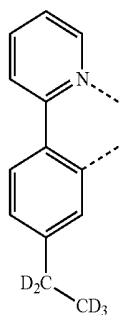

L1-36

5

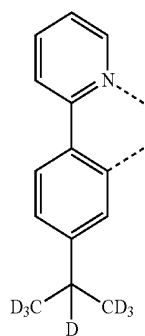

L1-37

15

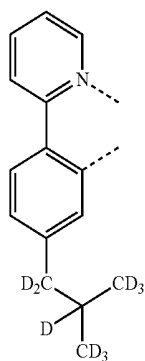

L1-38

30

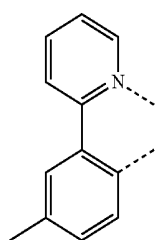

L1-39

45

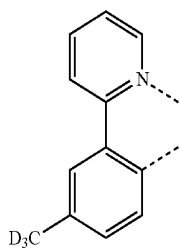

L1-40

55

60

58

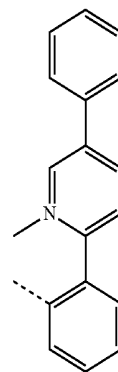

L2-1

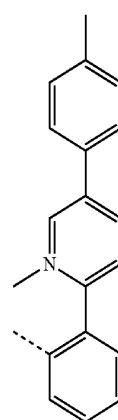

L2-2

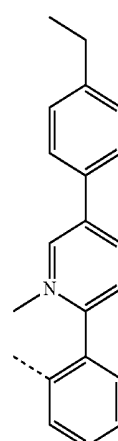

L2-3

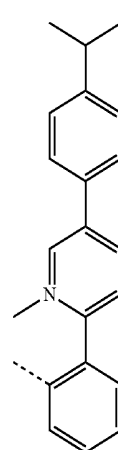

L2-4

In one embodiment of the composition where the first compound and the second compound each independently has the formula of  $\text{Ir}(\text{L}^1)_2(\text{L}^2)$  as defined above,  $\text{L}^2$  is selected from the group consisting of:

65

59

-continued

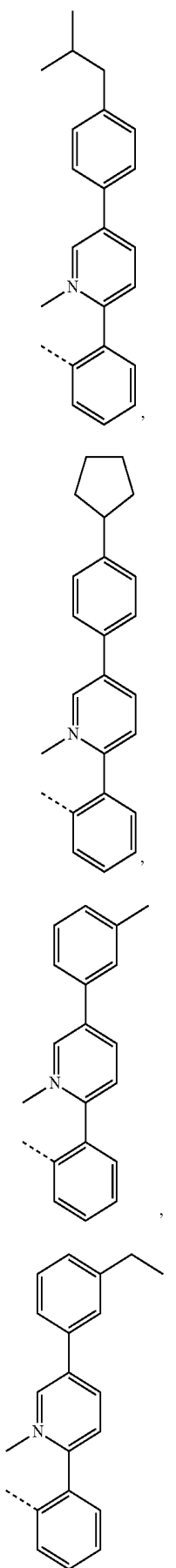

60

-continued

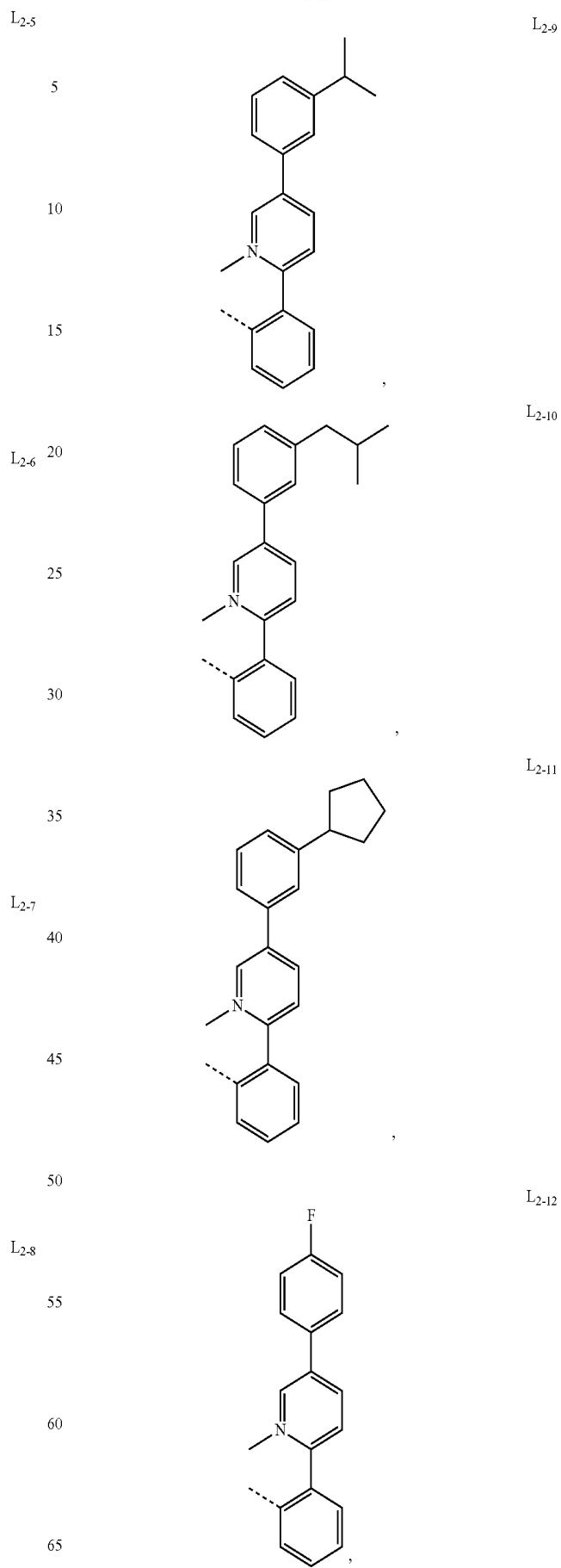

61

-continued

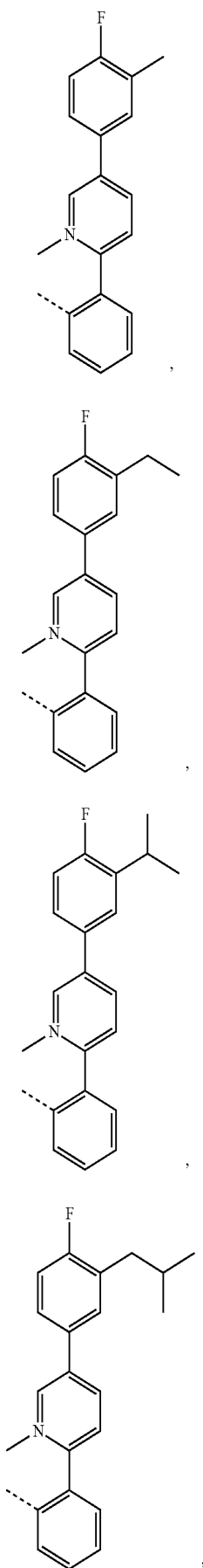

62

-continued

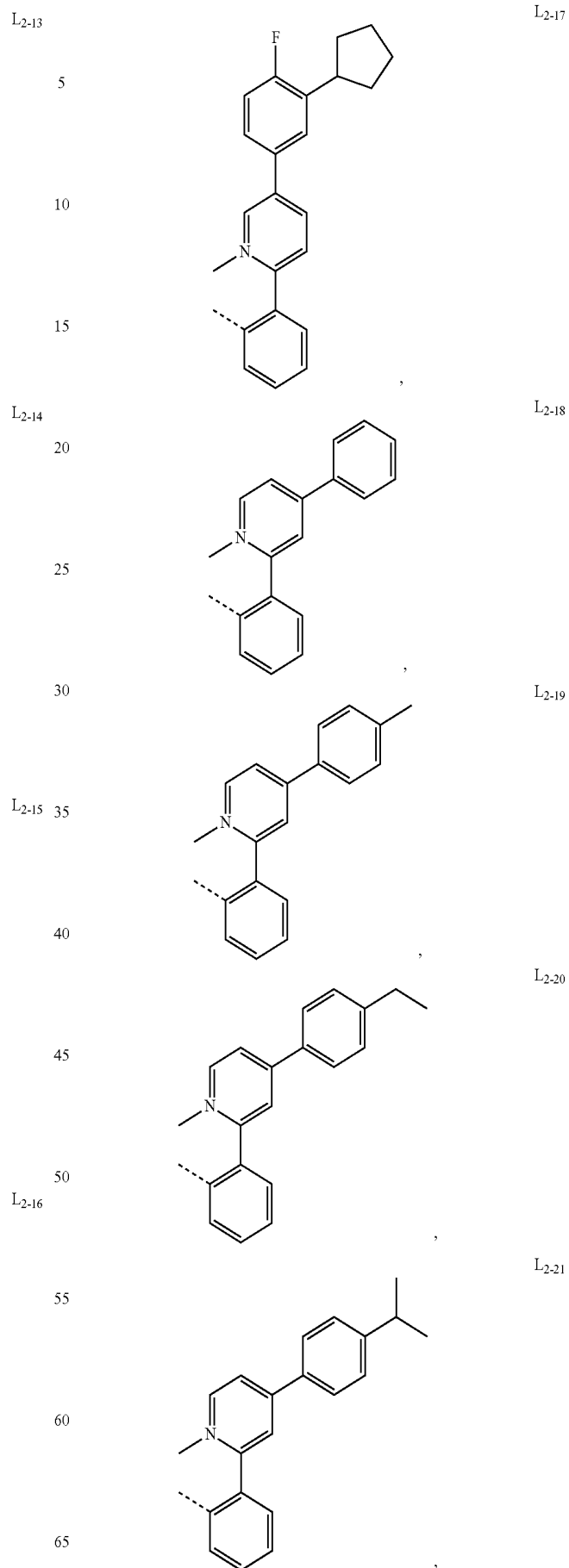

63

-continued

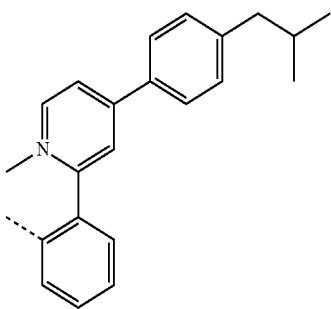

L<sub>2-22</sub>

5

10

15

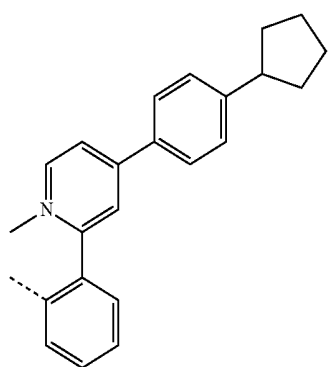

L<sub>2-23</sub>

20

25

30

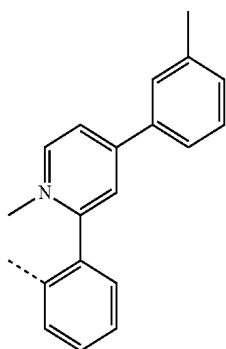

L<sub>2-24</sub>

40

45

50

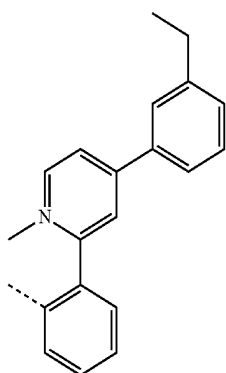

L<sub>2-25</sub>

55

60

65

64

-continued

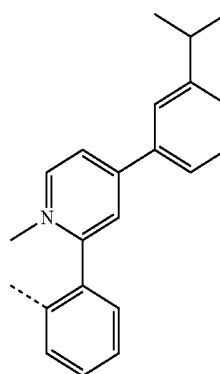

L<sub>2-26</sub>

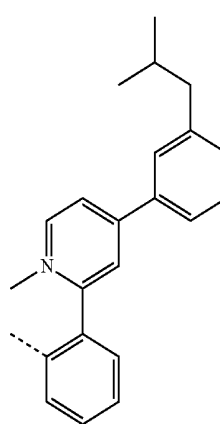

L<sub>2-27</sub>

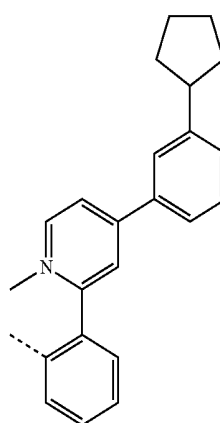

L<sub>2-28</sub>

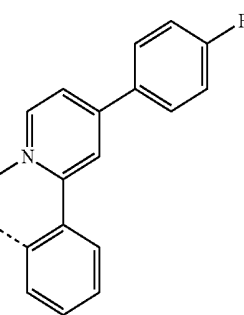

L<sub>2-29</sub>

**65**  
-continued

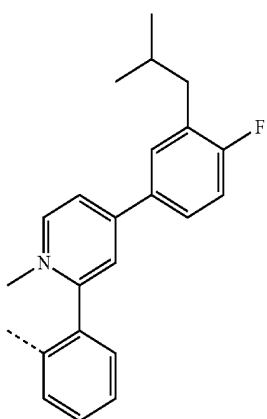
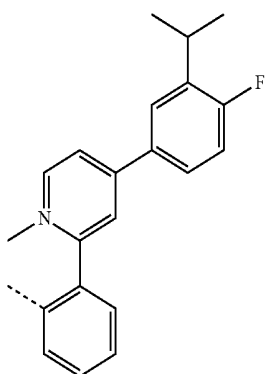
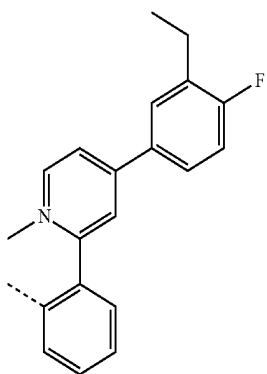
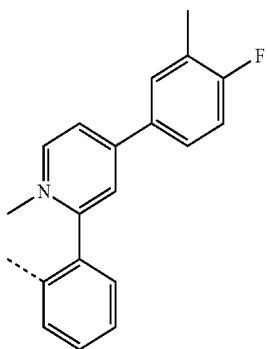

**66**  
-continued

L<sub>2-30</sub>

5

L<sub>2-34</sub>

10

L<sub>2-31</sub>

20

L<sub>2-35</sub>

25

30

L<sub>2-32</sub>

35

L<sub>2-36</sub>

40

45

L<sub>2-33</sub>

50

L<sub>2-37</sub>

55

60

65

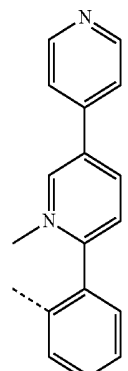
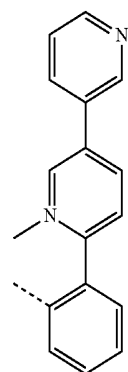
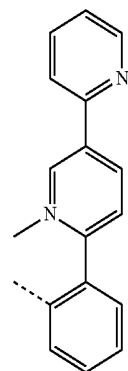
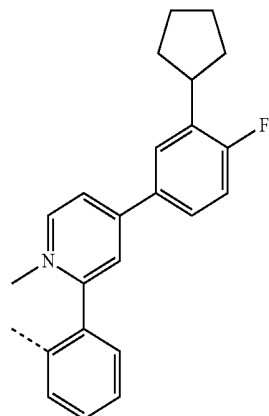

67

-continued

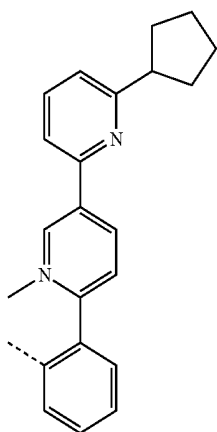
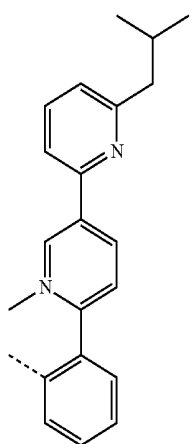
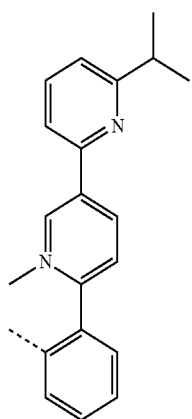
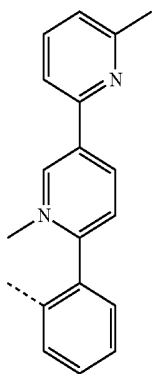

L2-38

5

10

15

L2-39

20

25

30

L2-40

35

40

45

50

L2-41

55

60

65

68

-continued

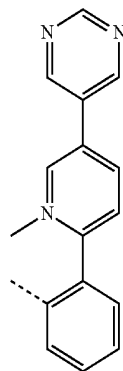
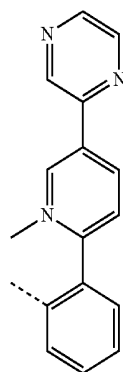
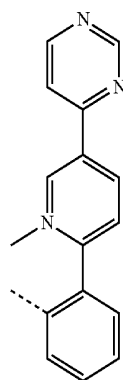
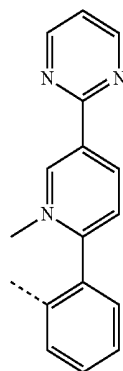

L2-42

L2-43

L2-44

L2-45

69

-continued

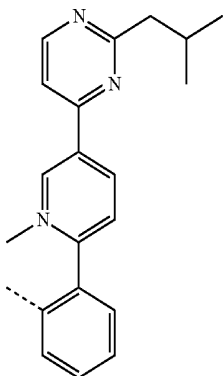
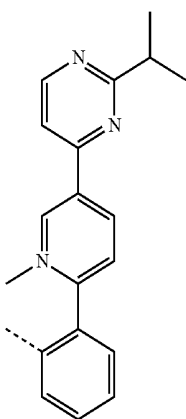
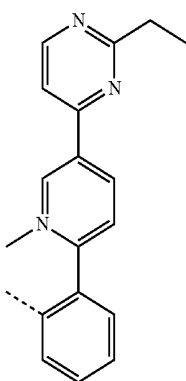
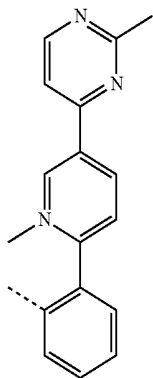

70

-continued

L<sub>2-46</sub>

5

L<sub>2-50</sub>

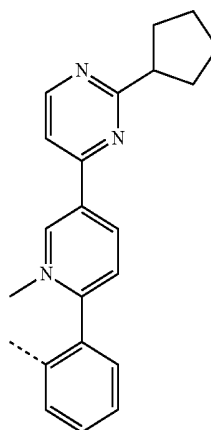

L<sub>2-47</sub>

20

25

L<sub>2-51</sub>

L<sub>2-48</sub>

35

40

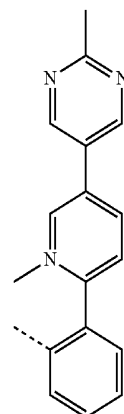

45

50

L<sub>2-52</sub>

L<sub>2-49</sub>

55

60

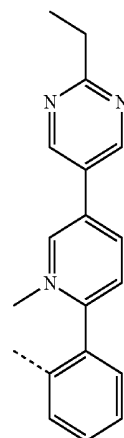

65

**71**  
-continued

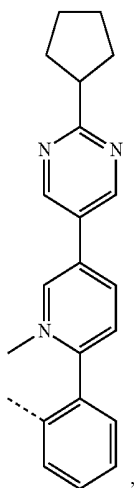
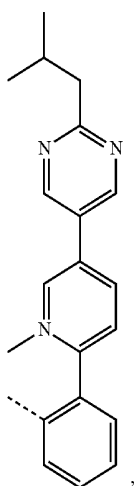
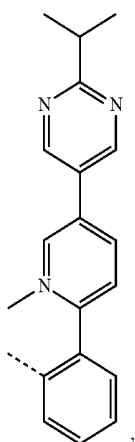

**72**  
-continued

L<sub>2-53</sub>

5



10

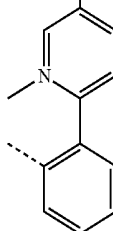

15

20

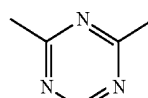

L<sub>2-54</sub>

25

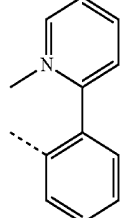

30

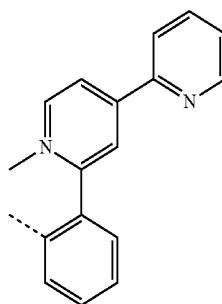

35

40

45

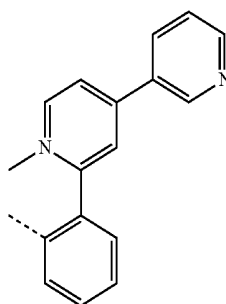

L<sub>2-55</sub>

50

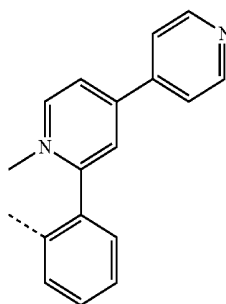

55

60

65

L<sub>2-56</sub>

L<sub>2-57</sub>

L<sub>2-58</sub>

L<sub>2-59</sub>

L<sub>2-60</sub>

73

-continued

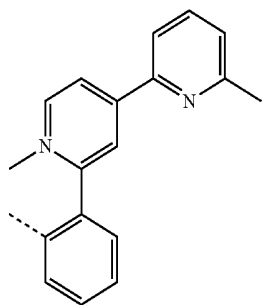

L2-61

5

10

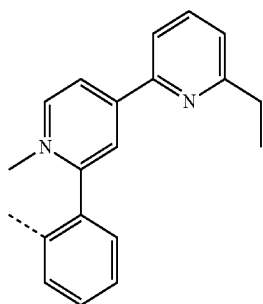

L2-62 15

20

25

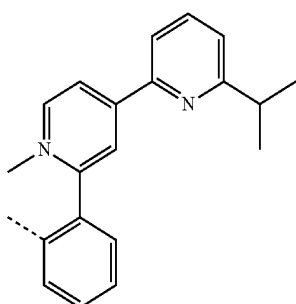

L2-63

30

35

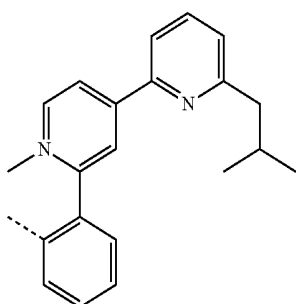

L2-64

45

50

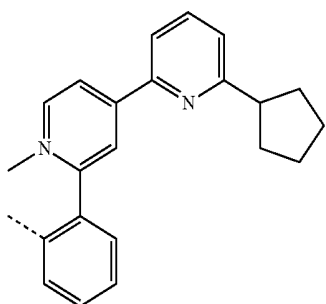

L2-65 55

60

65

74

-continued

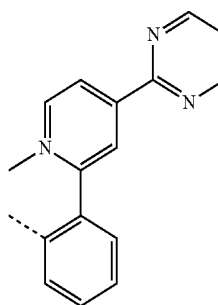

L2-66

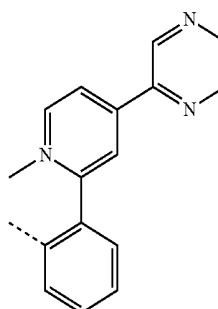

L2-67

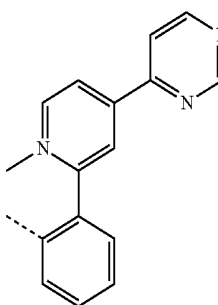

L2-68

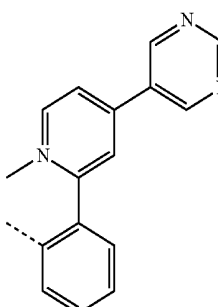

L2-69

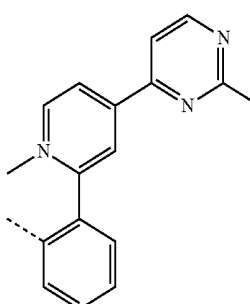

L2-70

**75**  
-continued

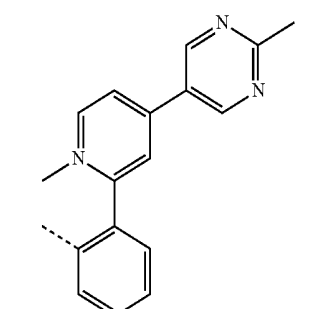
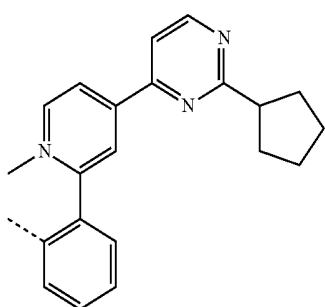
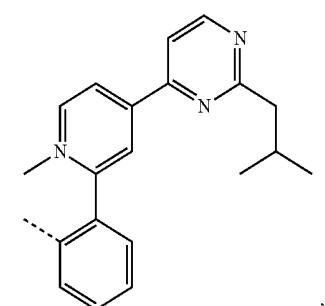
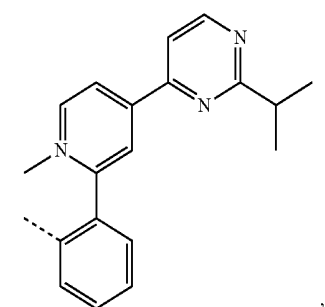
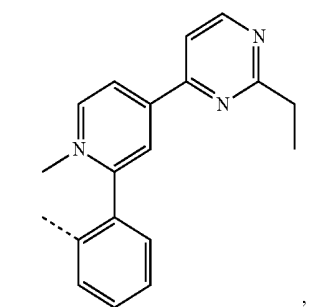

**76**  
-continued

L2-71

5

10

L2-72

15

20

L2-73

25

30

35

L2-74

40

45

50

L2-75

55

60

65

L2-76

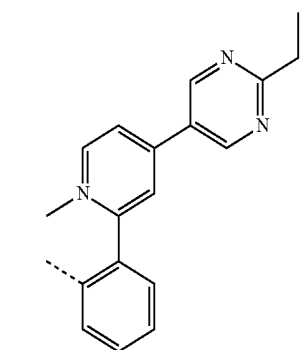

L2-77

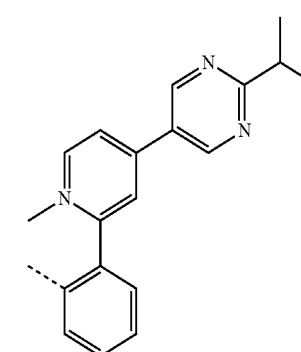

L2-78

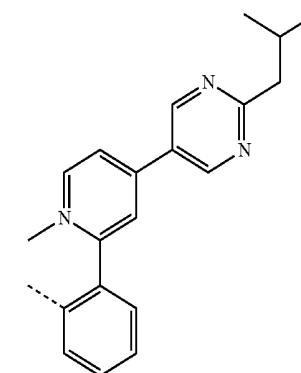

L2-79

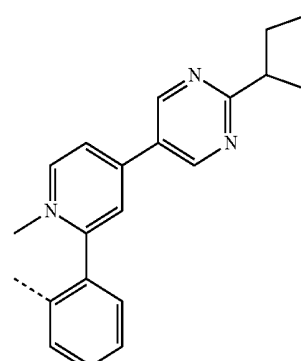

**77**  
-continued

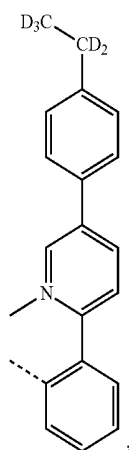
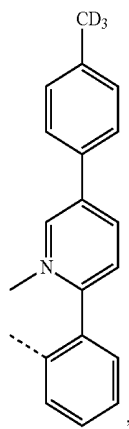
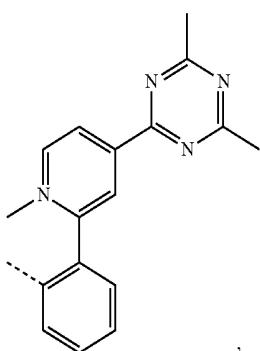
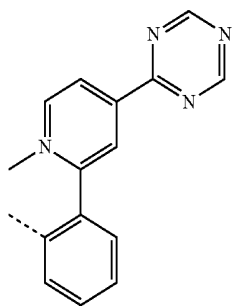

**78**  
-continued

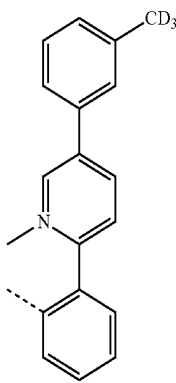
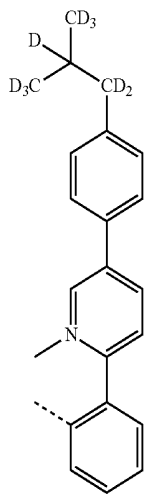
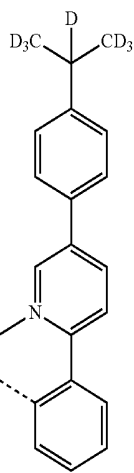

L<sub>2-80</sub>

5

10

L<sub>2-81</sub>

15

20

25

30

L<sub>2-82</sub>

35

40

45

L<sub>2-83</sub>

50

55

60

65

L<sub>2-84</sub>

L<sub>2-85</sub>

L<sub>2-86</sub>

79

-continued

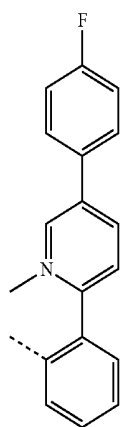
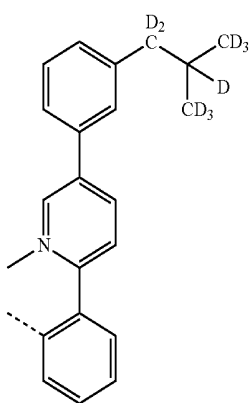
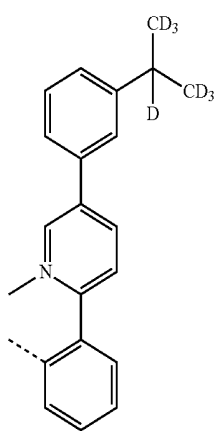
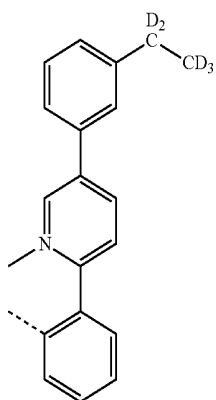

80

-continued

L<sub>2-87</sub>

5

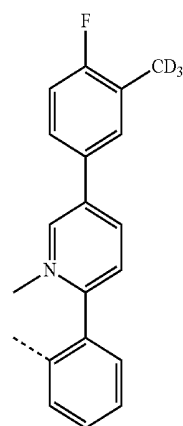

10

15

L<sub>2-88</sub>

20

25

30

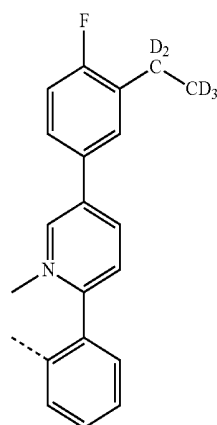

L<sub>2-89</sub>

35

40

45

50

L<sub>2-90</sub>

55

60

65

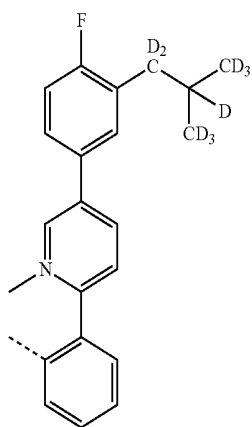
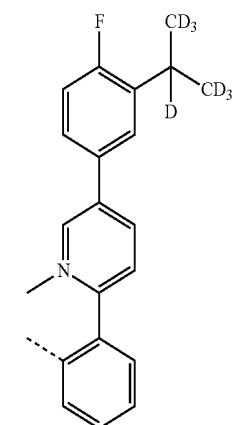

L<sub>2-91</sub>

L<sub>2-92</sub>

L<sub>2-93</sub>

L<sub>2-94</sub>

**81**

-continued

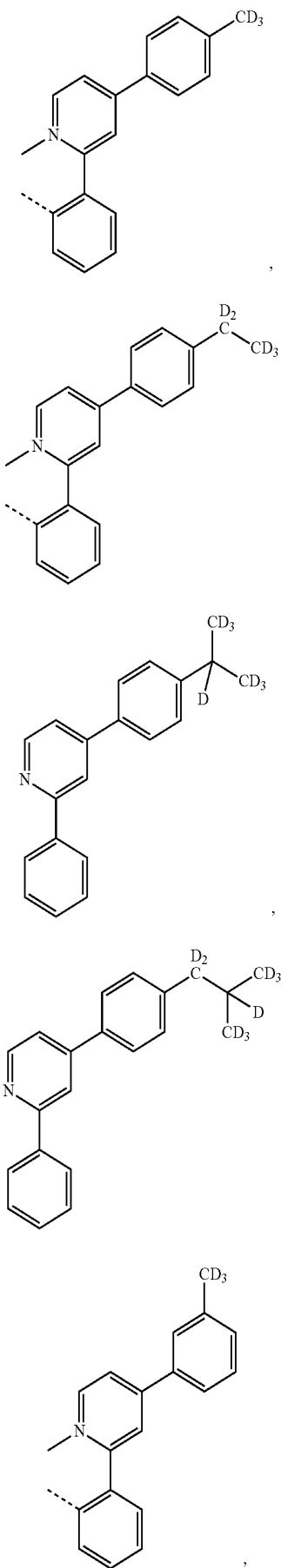

**82**

-continued

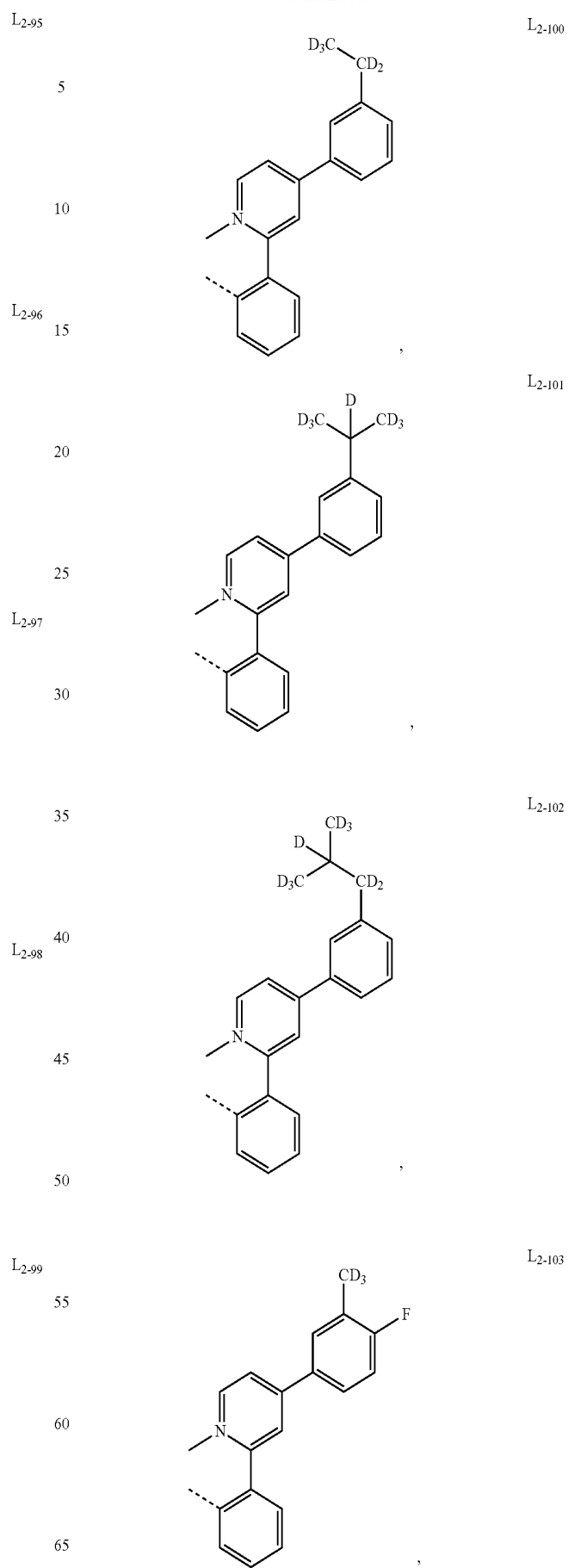

L<sub>2-95</sub>

5

10

L<sub>2-96</sub>

15

20

25

L<sub>2-97</sub>

30

35

L<sub>2-98</sub>

45

50

L<sub>2-99</sub>

55

60

65

L<sub>2-100</sub>

L<sub>2-101</sub>

L<sub>2-102</sub>

L<sub>2-103</sub>

83

-continued

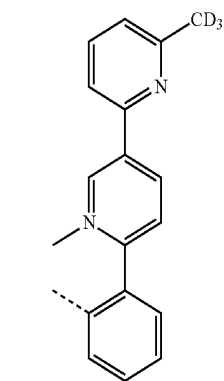
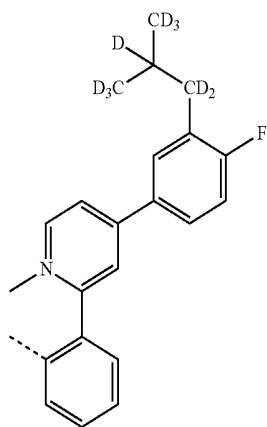
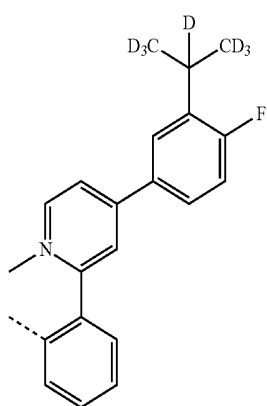
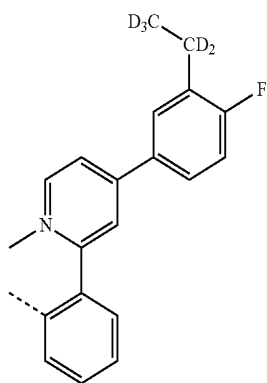

84

-continued

L2-104

5

10

15

L2-105

20

25

30

L2-106

35

40

45

50

L2-107

55

60

65

L2-108

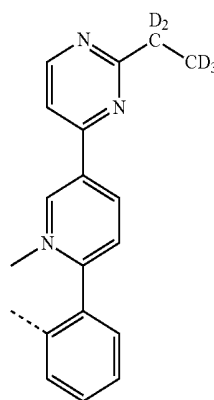
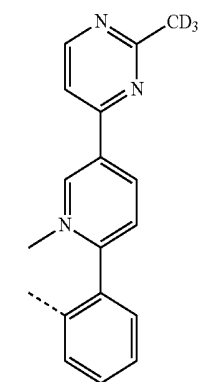
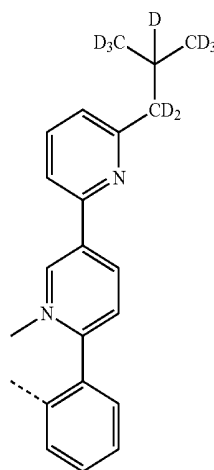
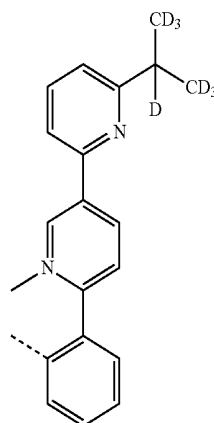

L2-109

L2-110

L2-111

85

-continued

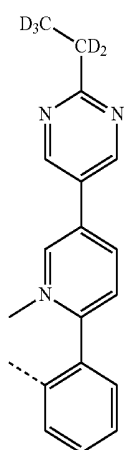
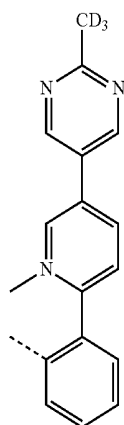
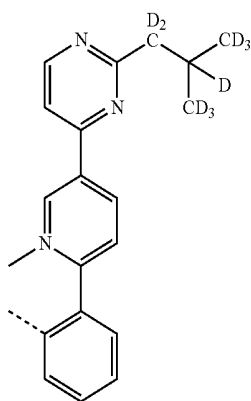
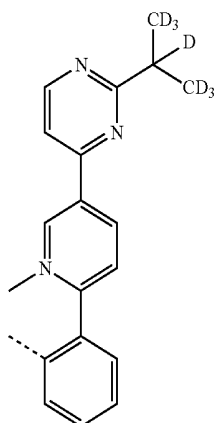

86

-continued

L2-112

5

10

15

L2-113

20

25

30

L2-114

35

40

45

L2-115

50

55

60

65

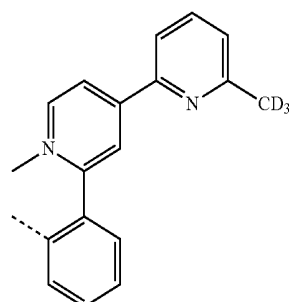
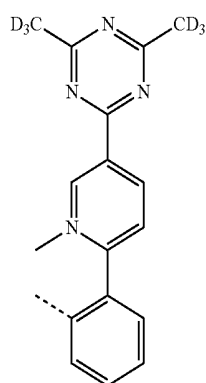
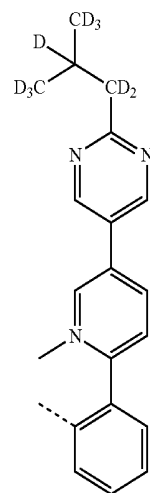
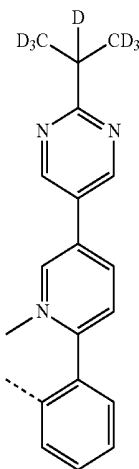

L2-116

L2-117

L2-118

L2-119

87

-continued

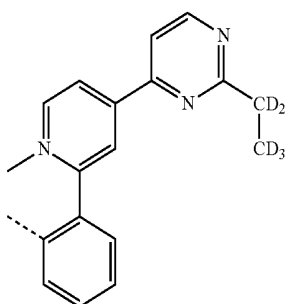
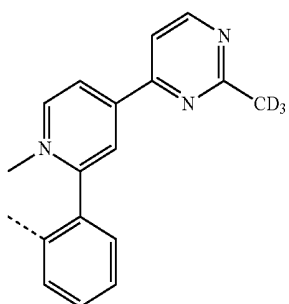
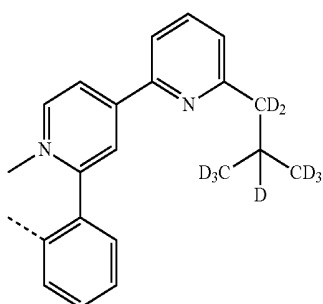
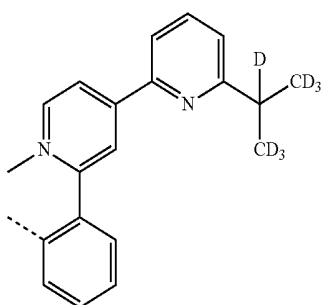
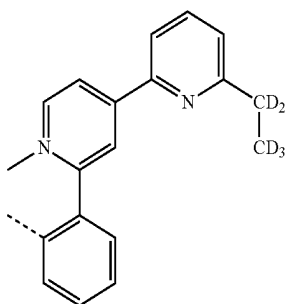

88

-continued

L<sub>2</sub>-120

5

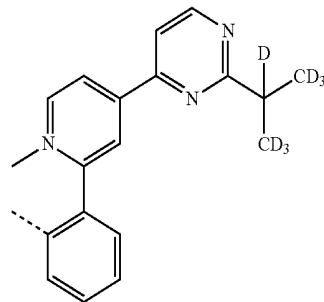

10

L<sub>2</sub>-121

15

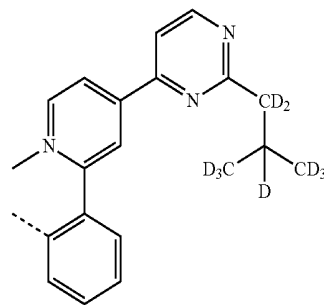

20

25

L<sub>2</sub>-122

30

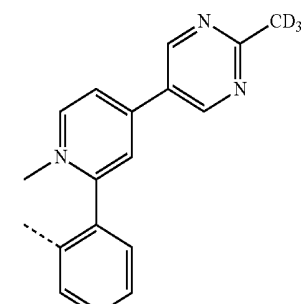

35

40

L<sub>2</sub>-123

45

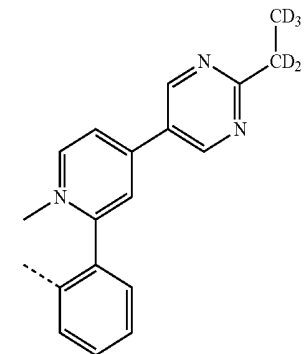

50

L<sub>2</sub>-124

55

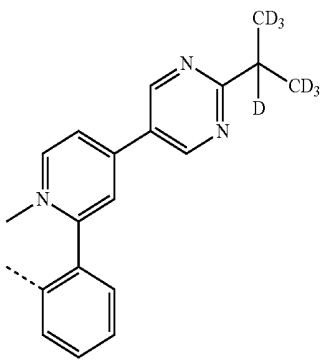

60

65

L<sub>2</sub>-125

L<sub>2</sub>-126

L<sub>2</sub>-127

L<sub>2</sub>-128

L<sub>2</sub>-129

89

-continued

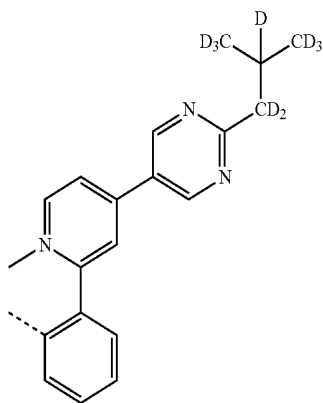

, and

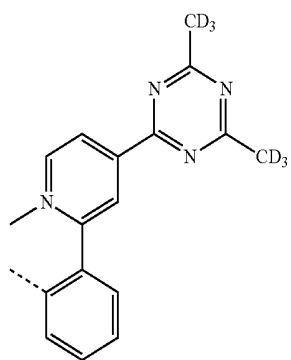

In one embodiment of the composition where the first compound and the second compound each independently has the formula of  $\text{Ir}(\text{L}^1)_2(\text{L}^2)$  as defined above, the first compound and the second compound are each independently selected from the group consisting of:

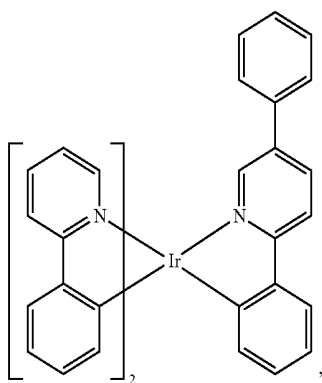

Compound 7

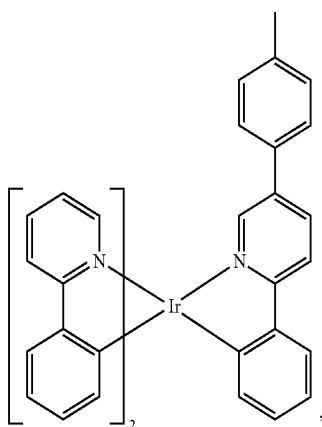

Compound 8

90

-continued

L<sub>2</sub>-130

5

10

15

L<sub>2</sub>-131

20

25

30

35

40

45

50

55

60

65

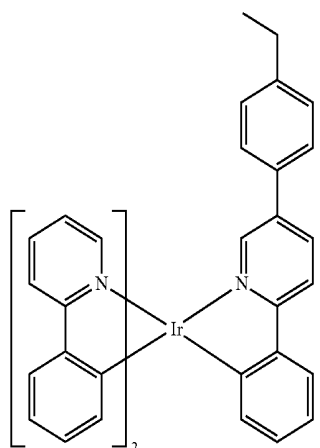

Compound 9

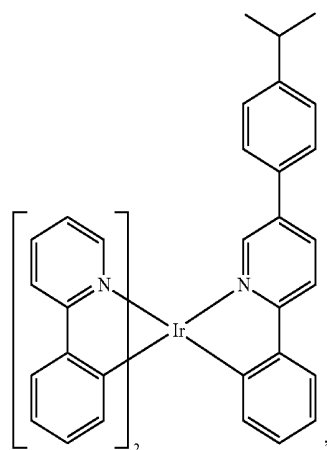

Compound 10

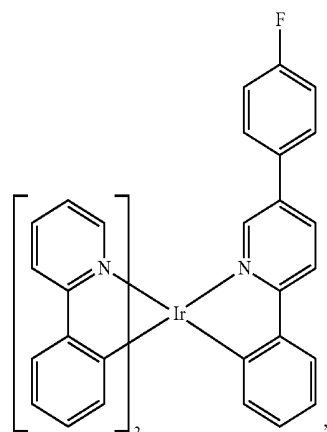

Compound 11

**91**  
-continued

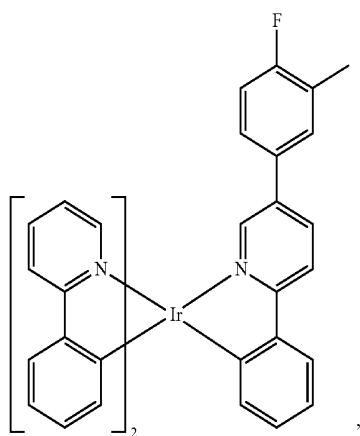

Compound 12

5

**92**  
-continued

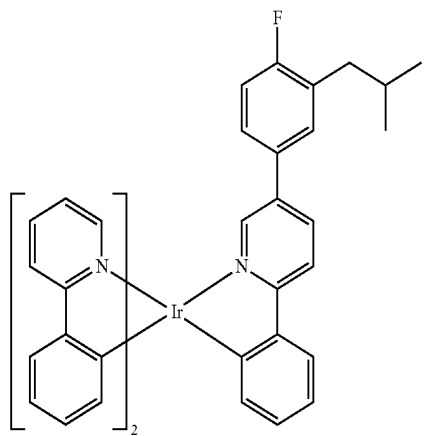

Compound 15

10

15

20

Compound 20

Compound 13

25

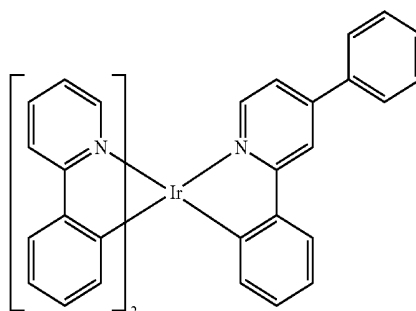
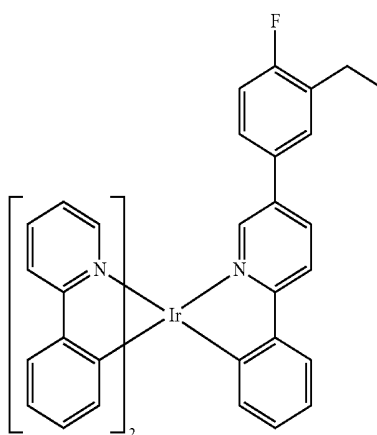

30

35

Compound 21

Compound 14

50

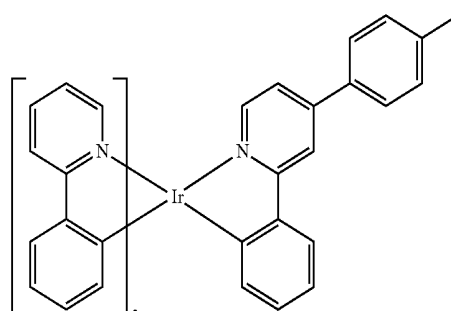
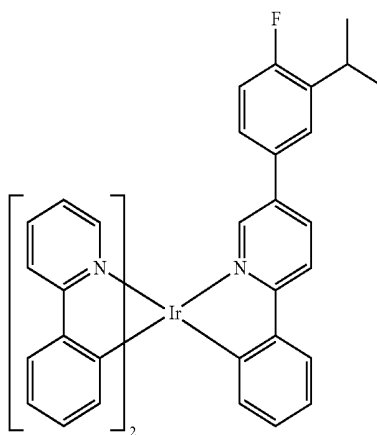

40

45

55

Compound 22

60

65

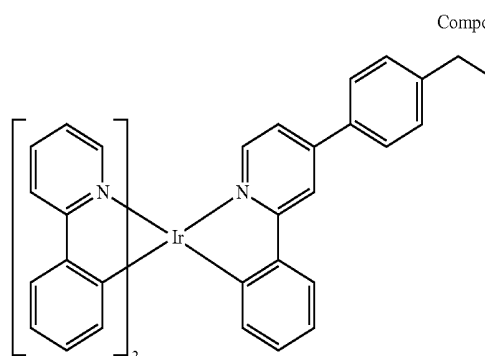

93  
-continued

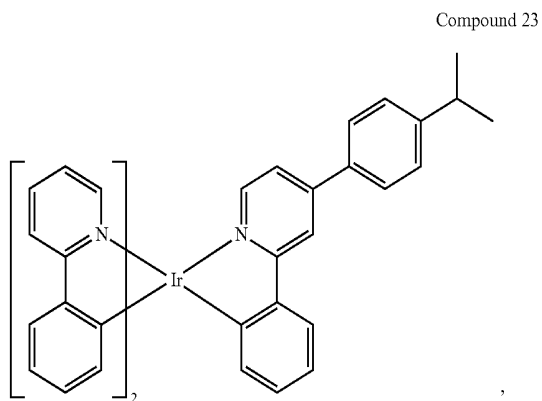

94  
-continued

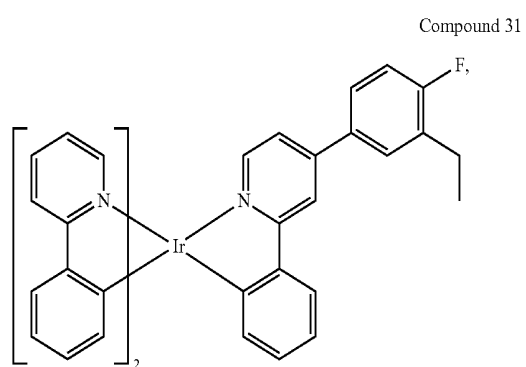
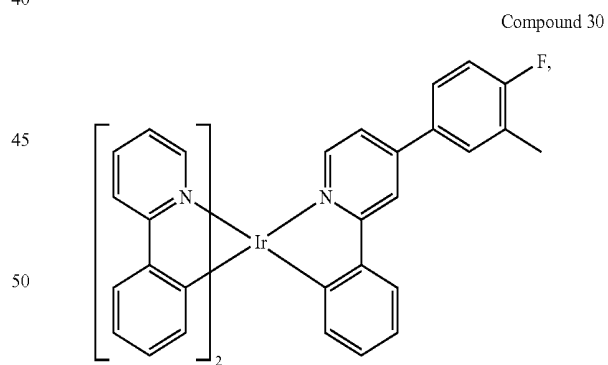
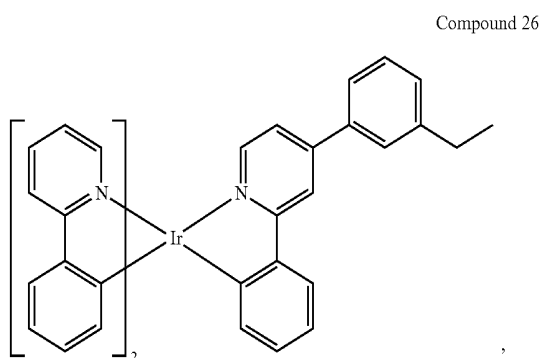
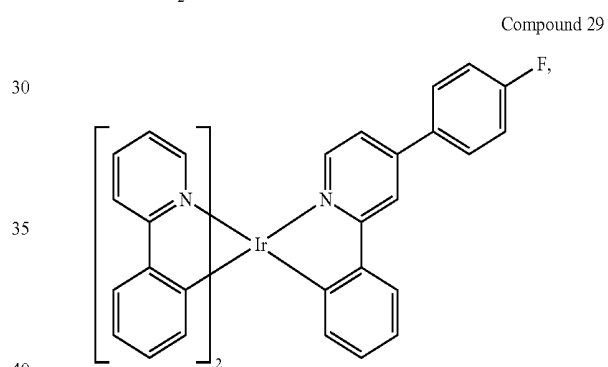
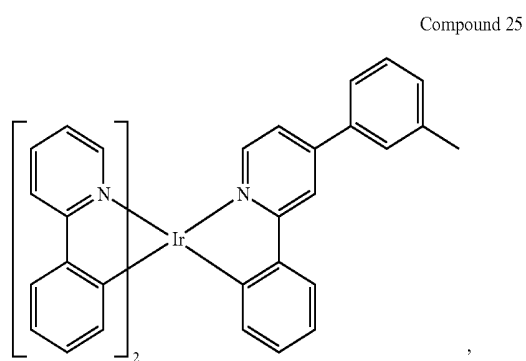
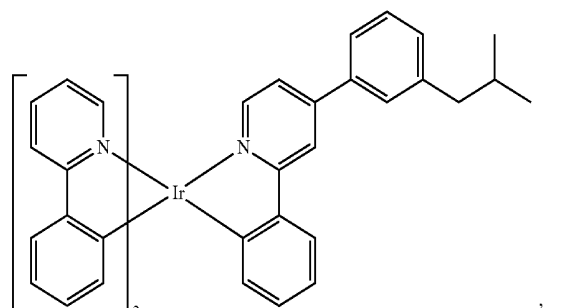
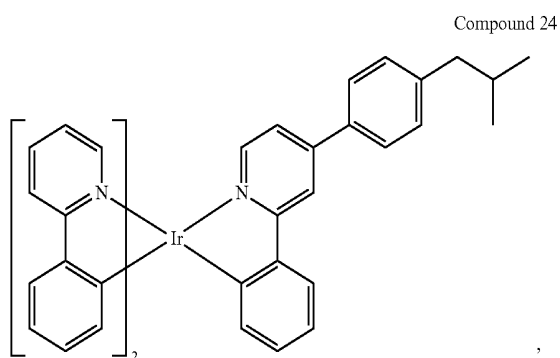
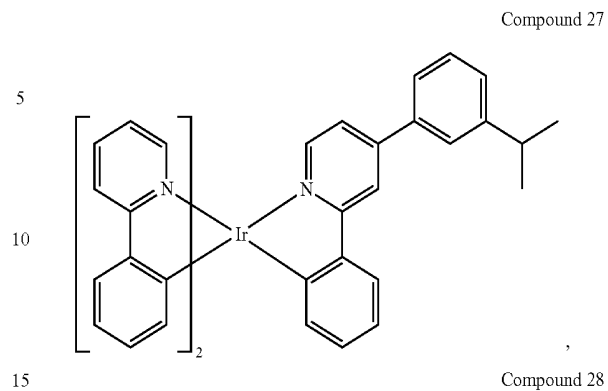

**95**  
-continued

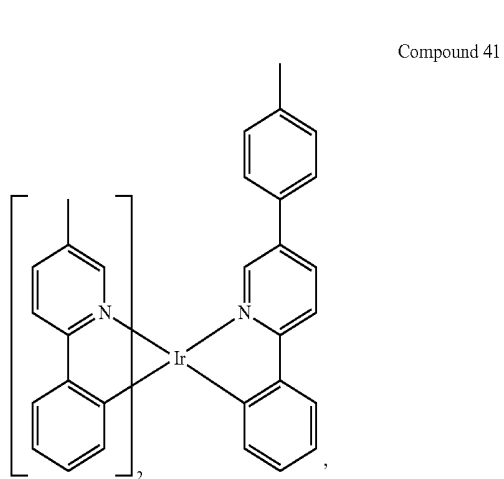
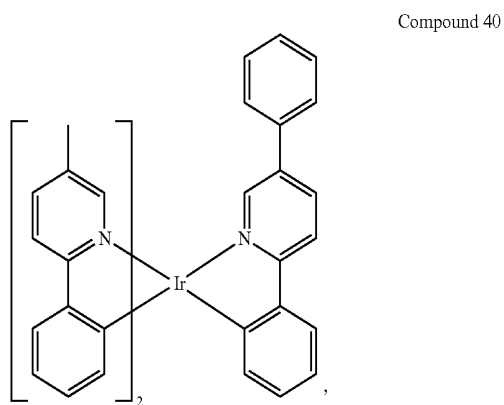
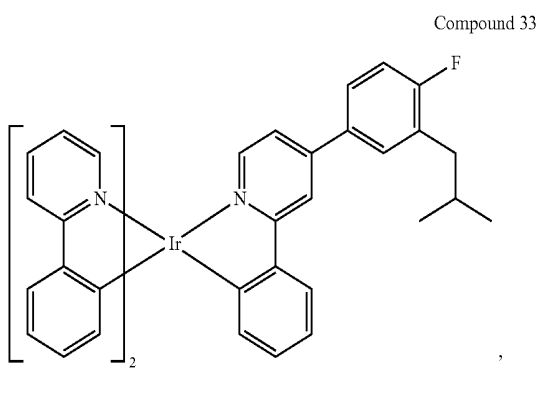
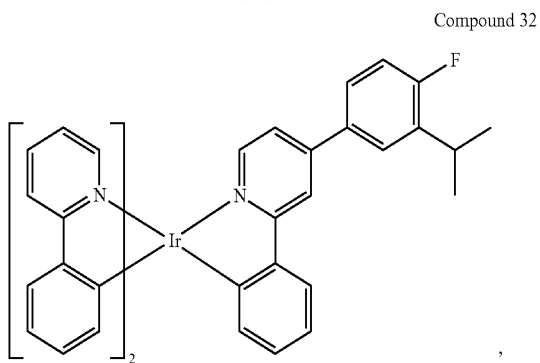

**96**  
-continued

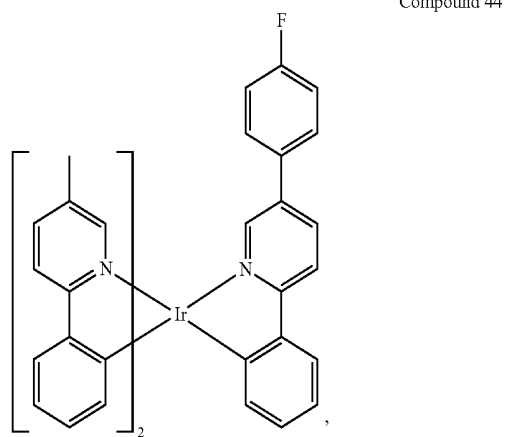
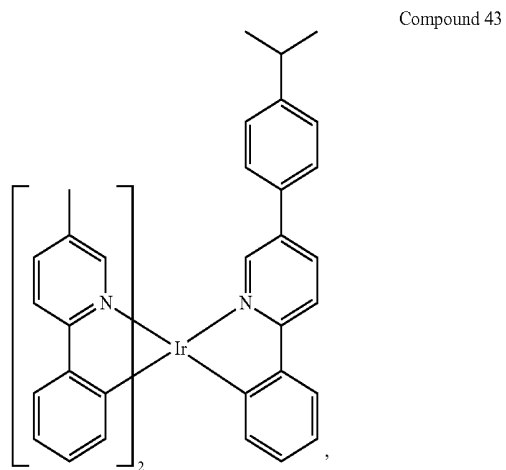
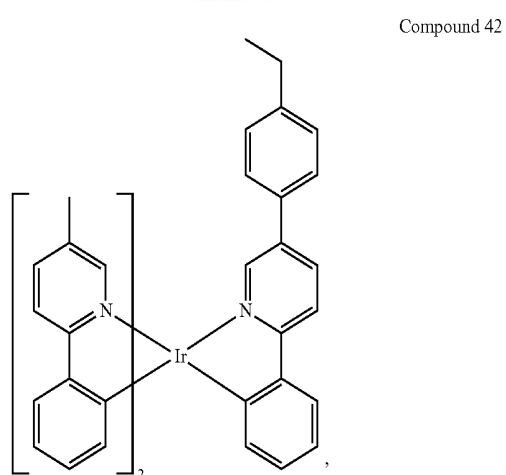

**97**  
-continued

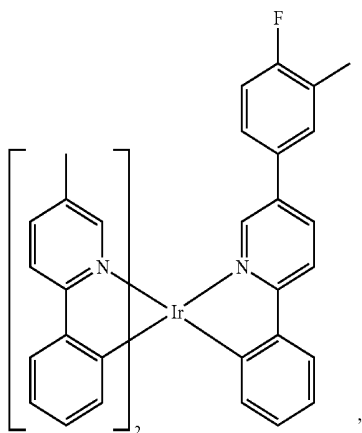

Compound 45

**98**  
-continued

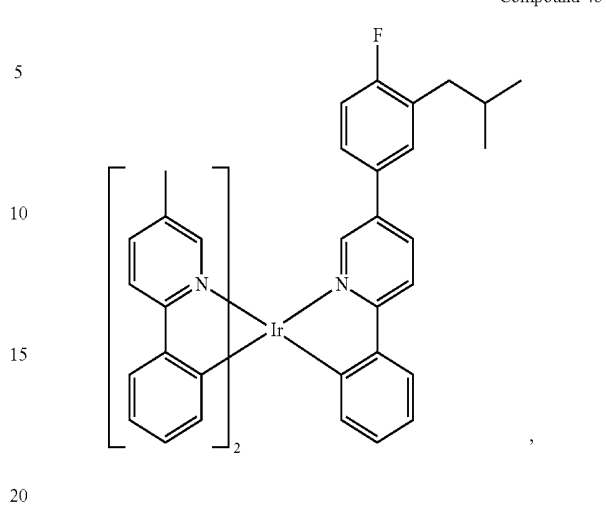

Compound 46

Compound 48

5

10

15

20

Compound 53

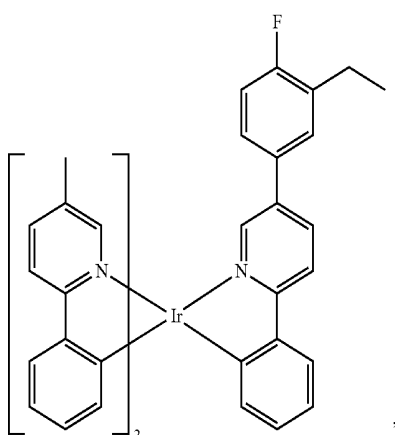

Compound 47

25

30

35

40

45

50

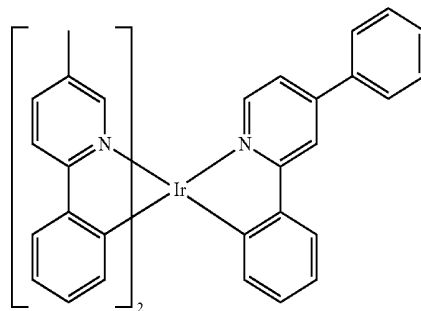

Compound 54

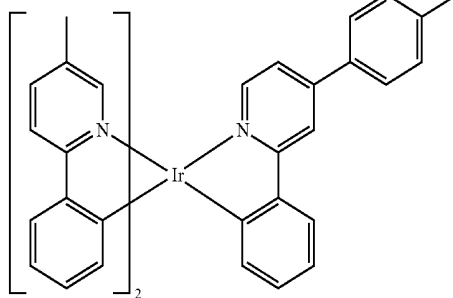

Compound 55

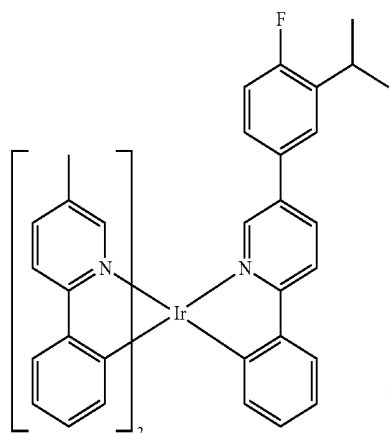

55

60

65

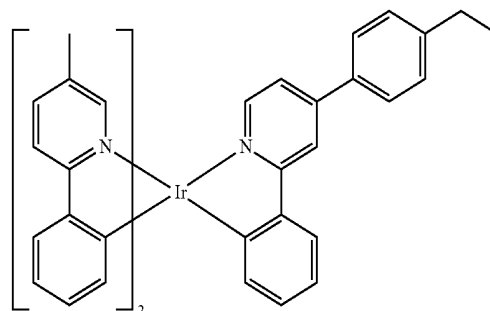

**99**  
-continued

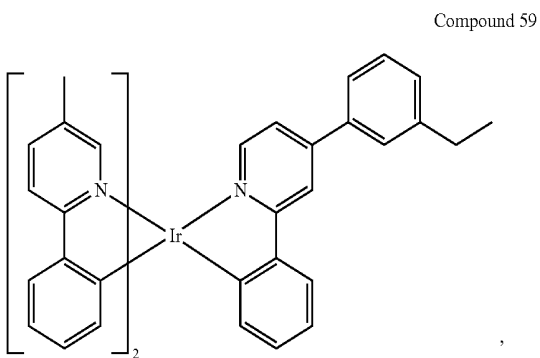
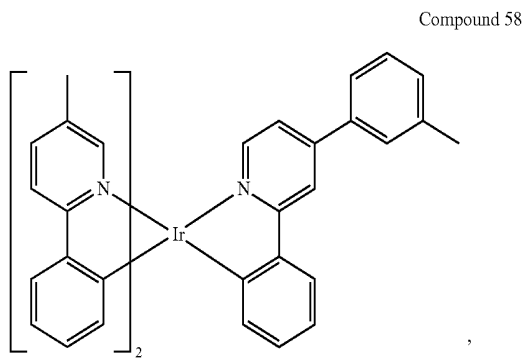
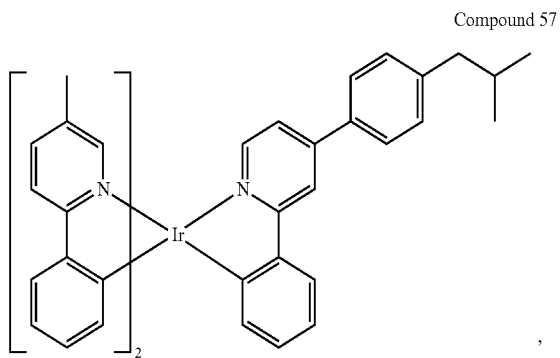
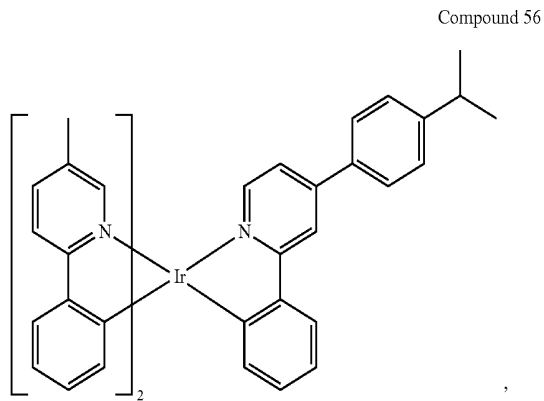

**100**  
-continued

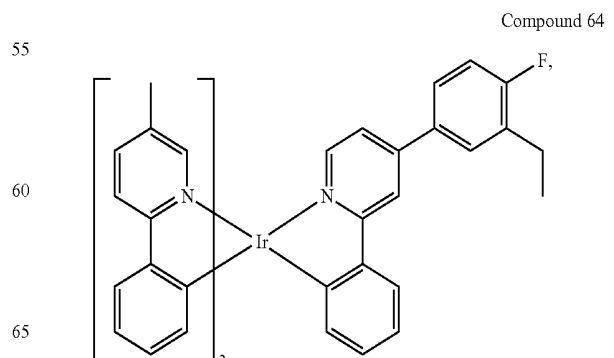
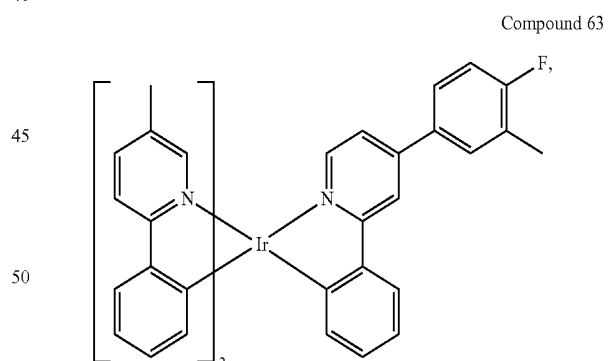
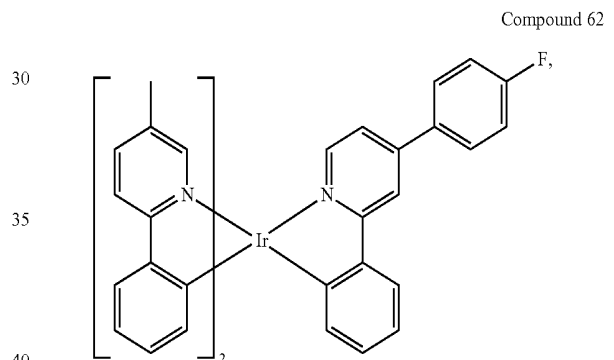
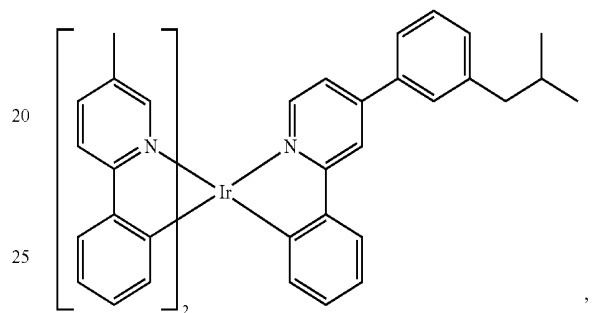
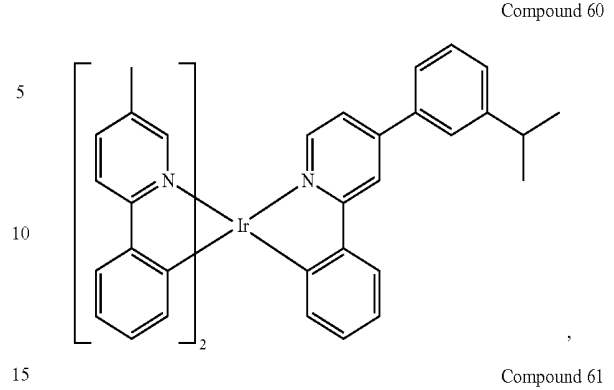

**101**  
-continued

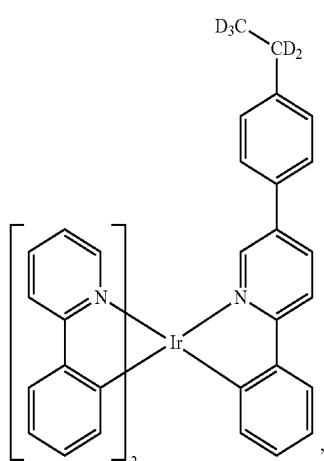
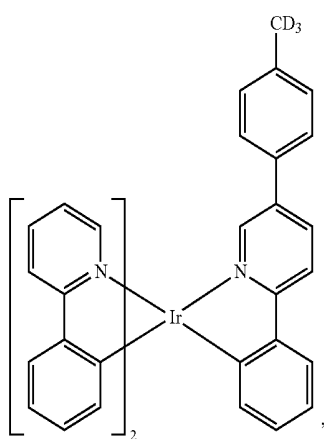
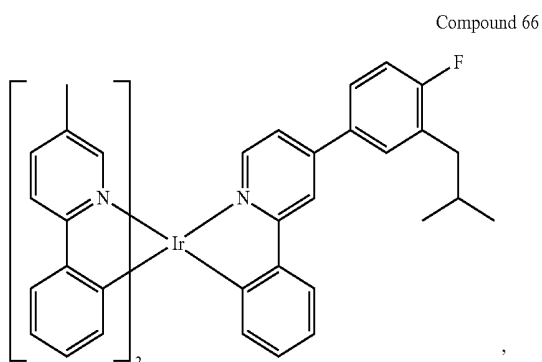
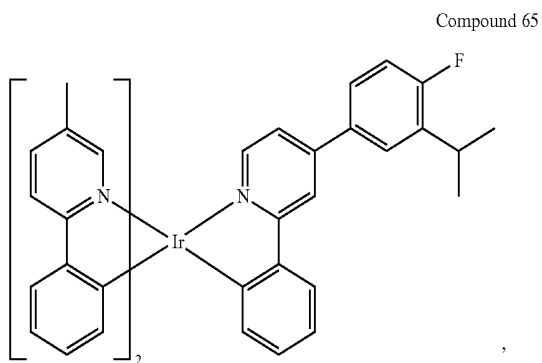

**102**  
-continued

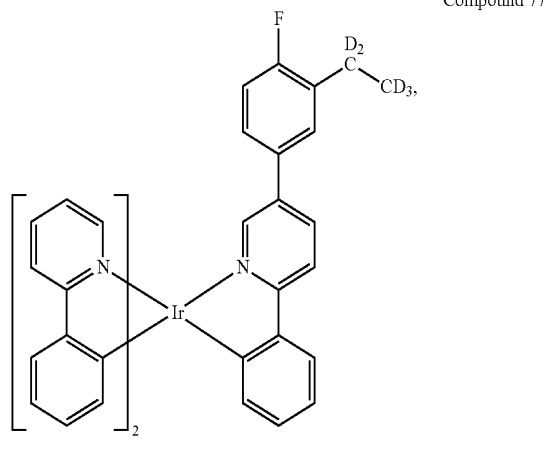
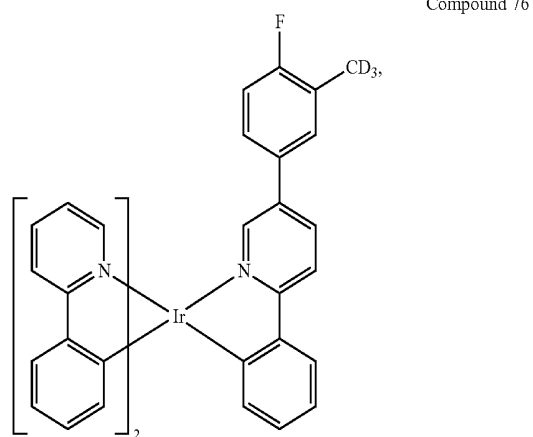
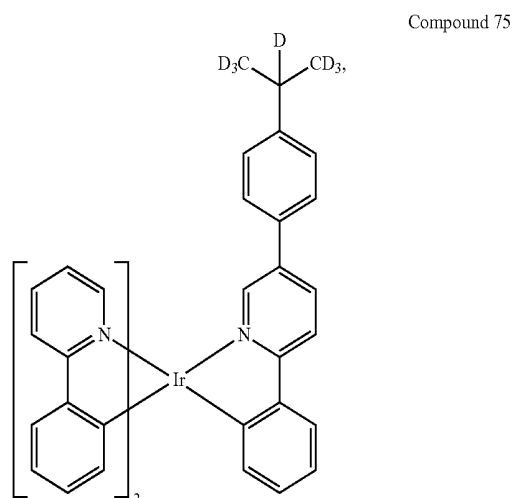

**103**  
-continued

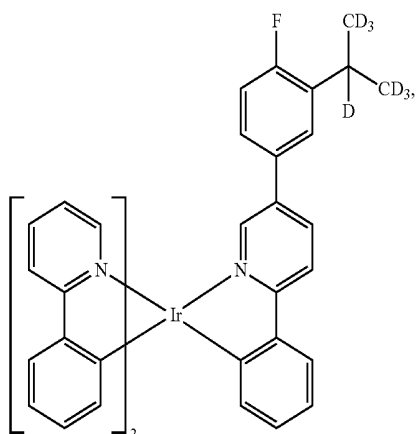

Compound 78

**104**  
-continued

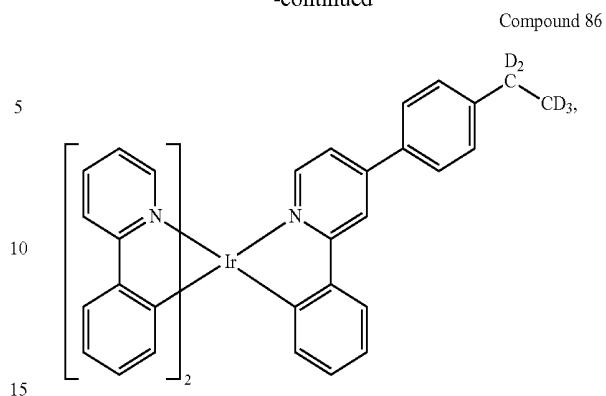

Compound 86

Compound 79

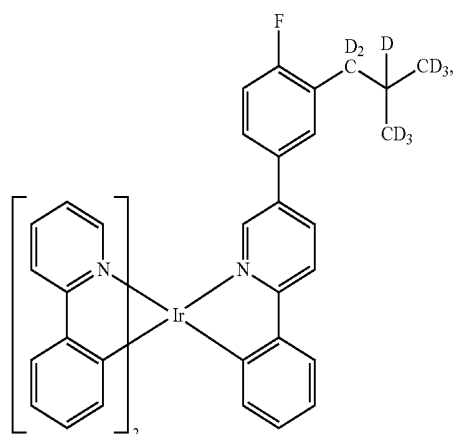

Compound 79

Compound 87

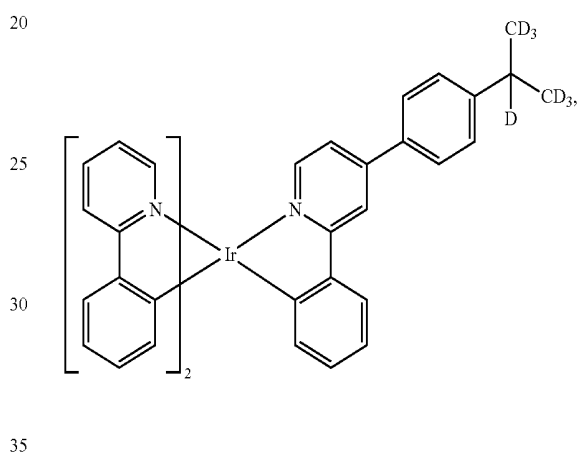

Compound 84

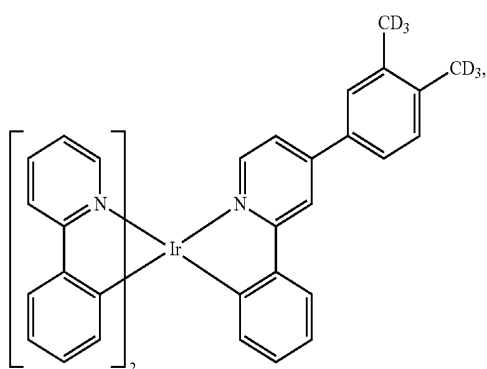

Compound 84

Compound 88

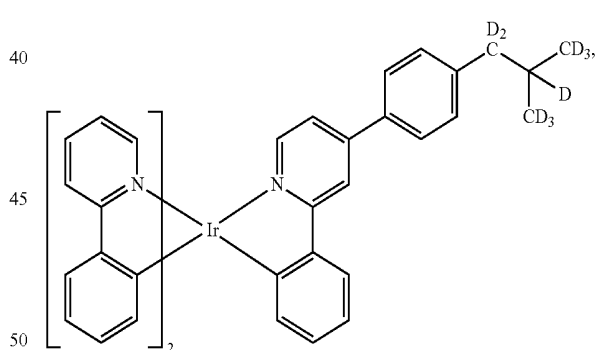

Compound 85

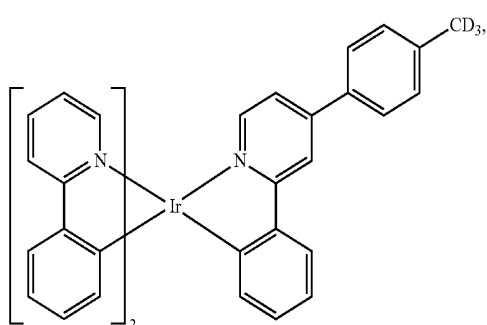

Compound 85

Compound 89

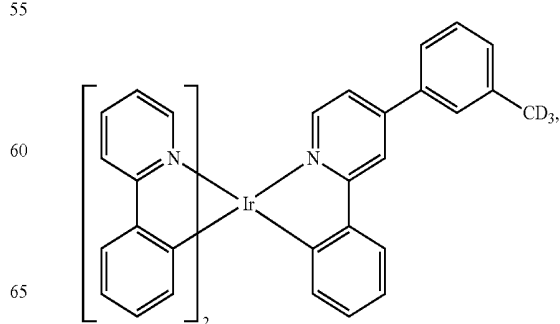

Compound 89

**105**  
-continued

**106**  
-continued

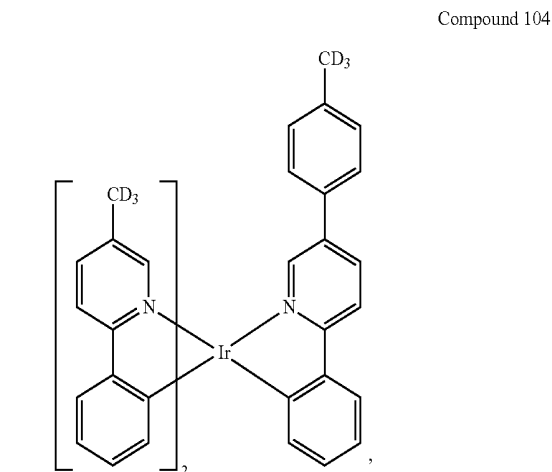
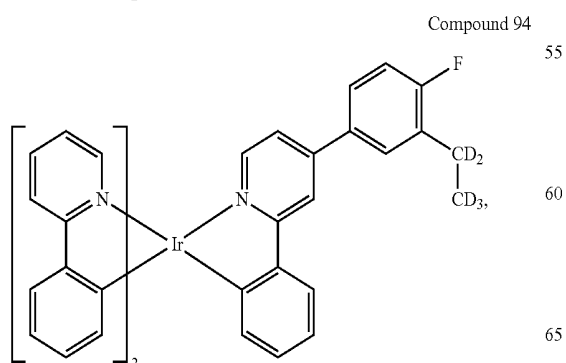
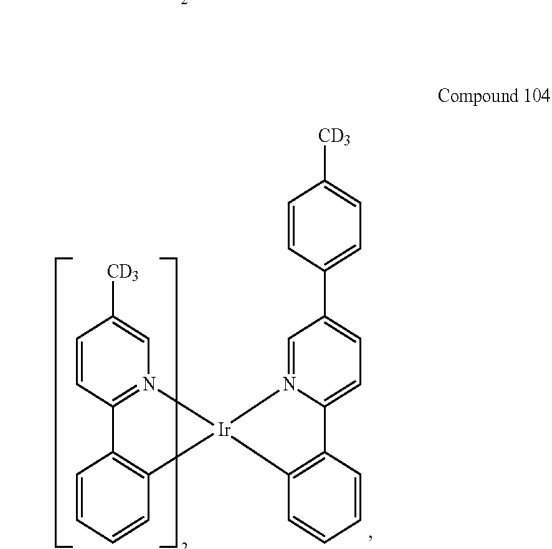
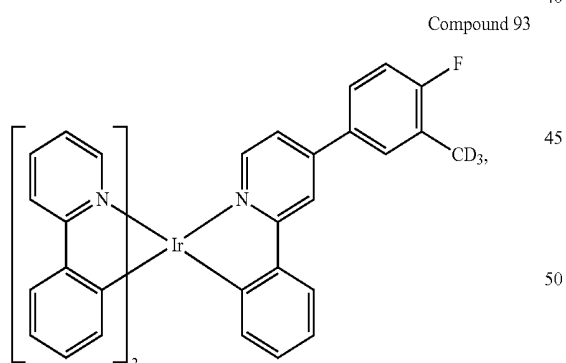
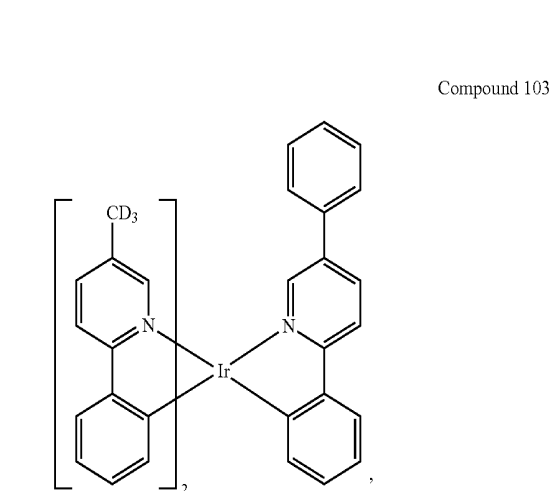
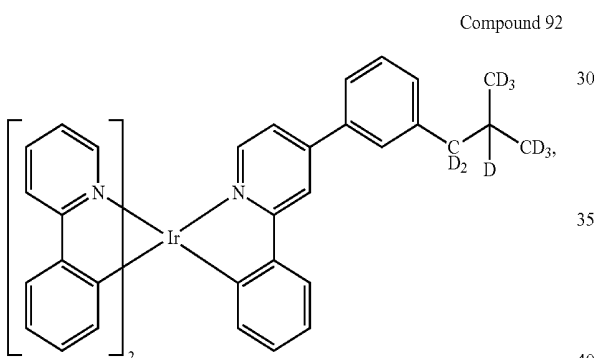
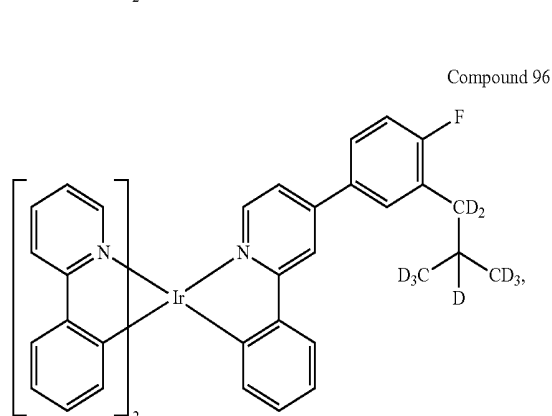
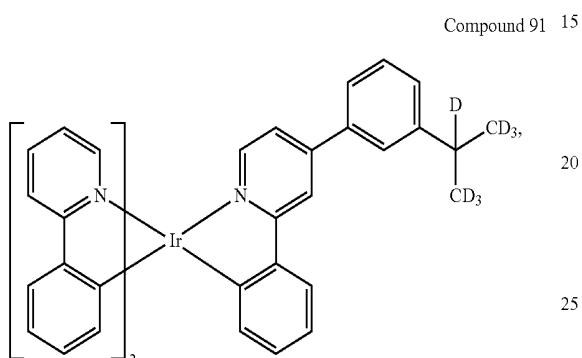
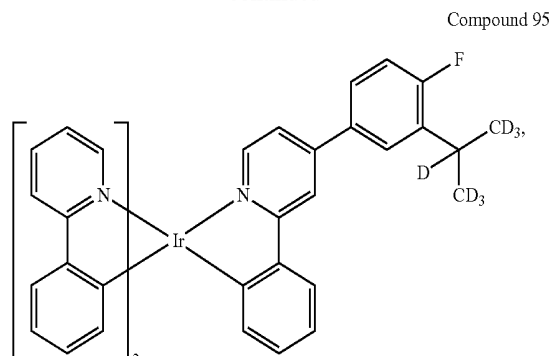
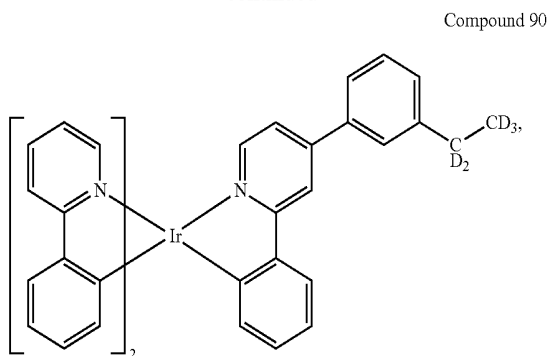

**107**  
-continued

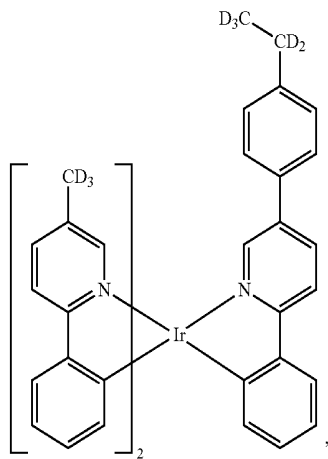

**108**  
-continued

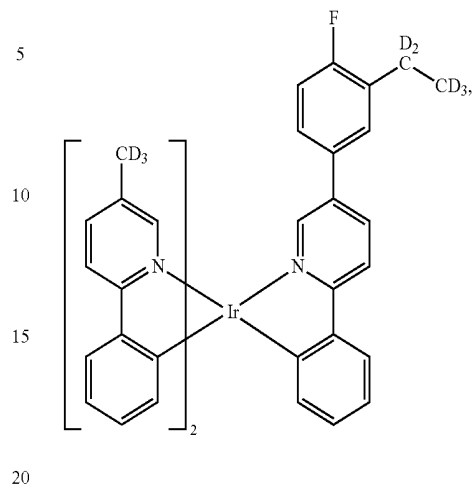

Compound 108

Compound 107

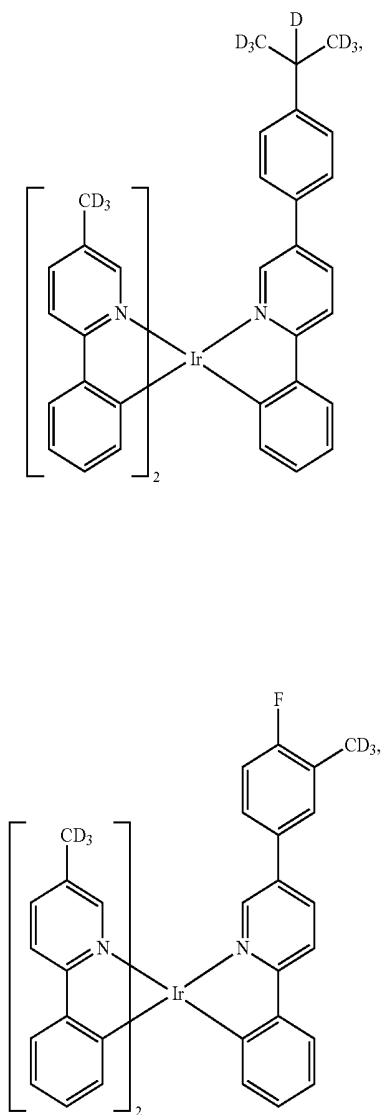

Compound 109

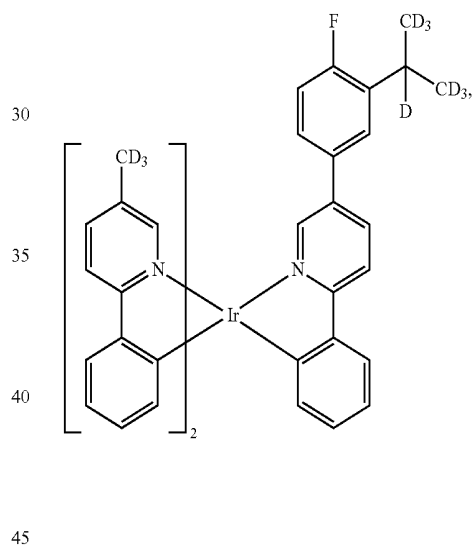

Compound 110

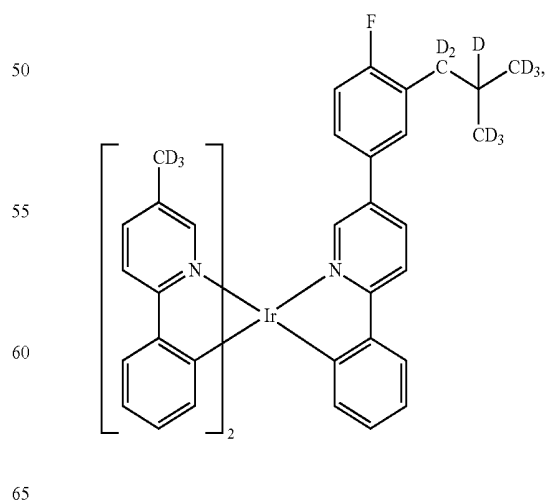

**109**  
-continued

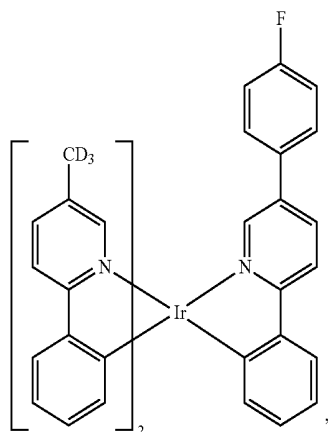

**110**  
-continued

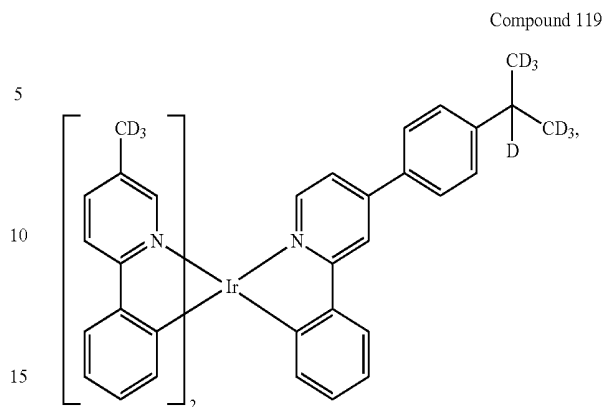

Compound 116

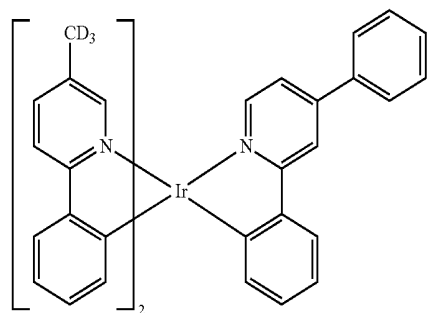

Compound 120

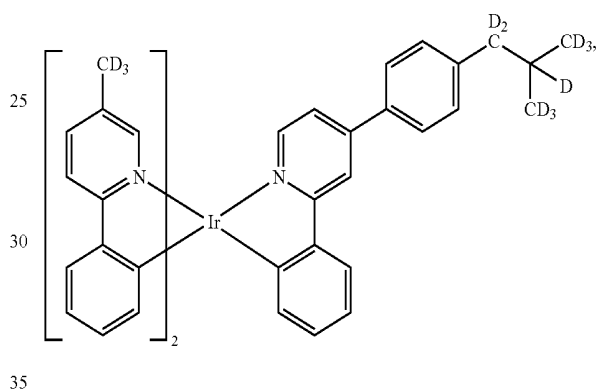

Compound 117

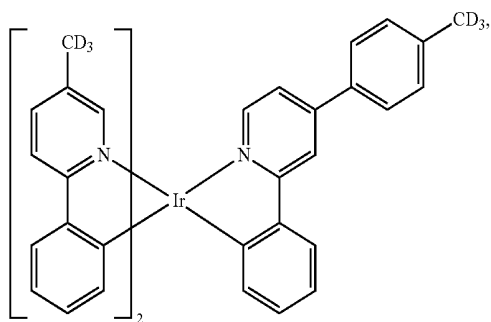

Compound 121

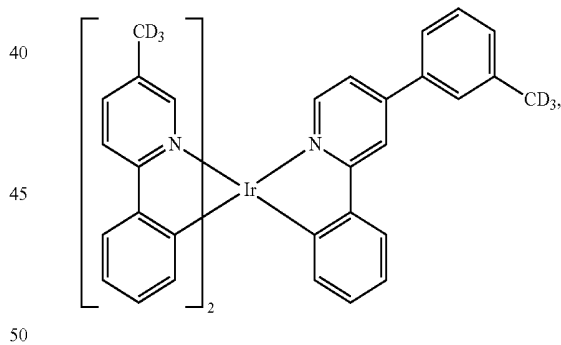

Compound 118

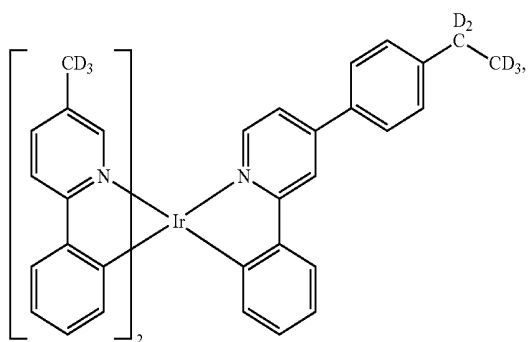

Compound 122

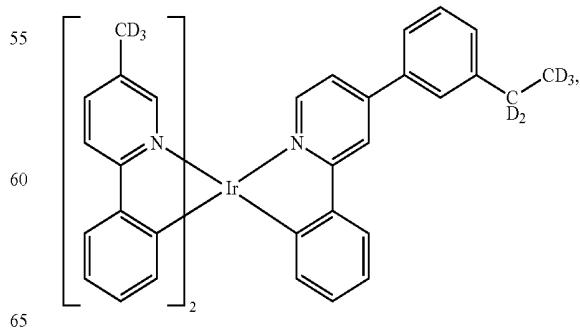

**111**  
-continued

**112**  
-continued

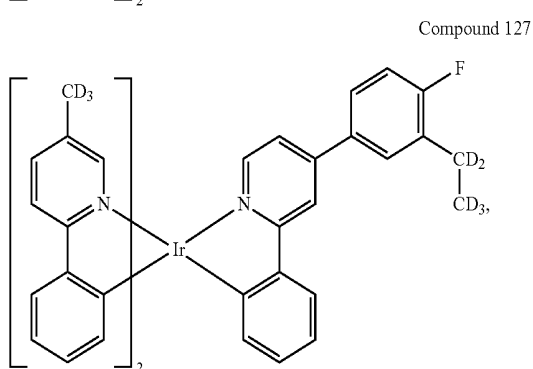
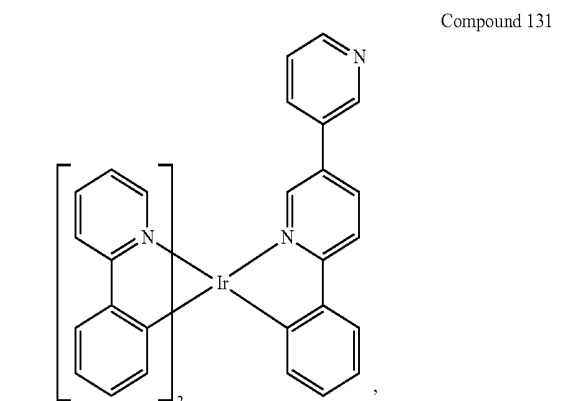
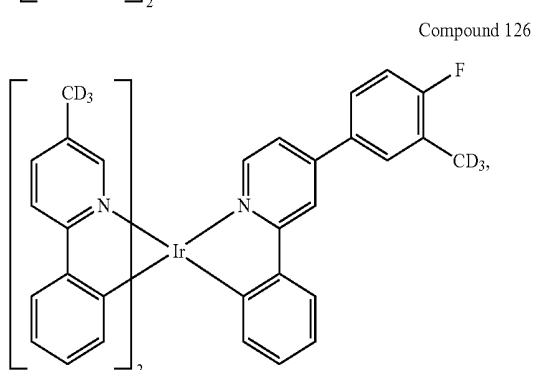
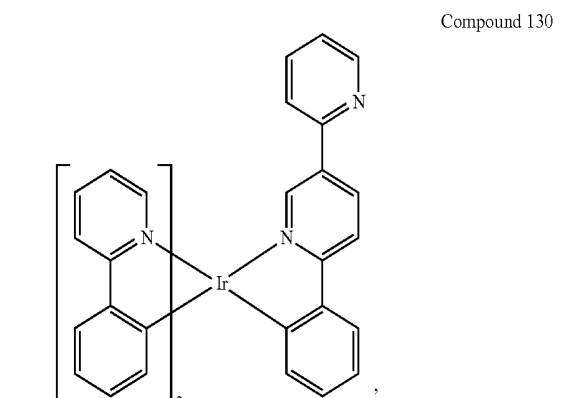
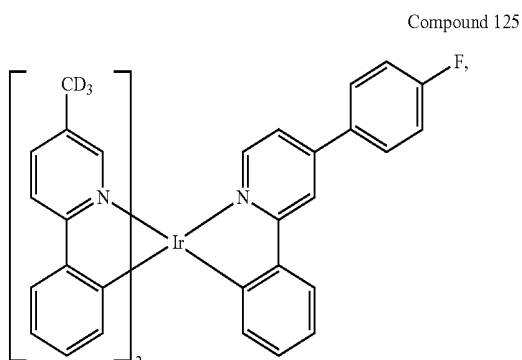
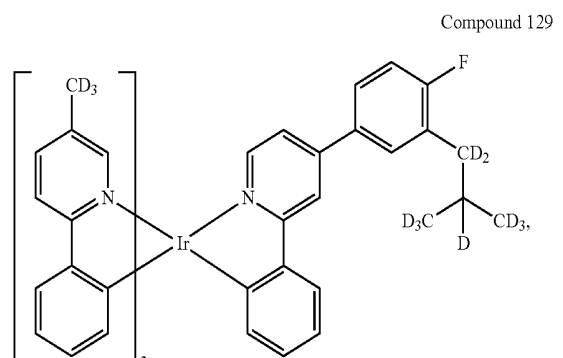
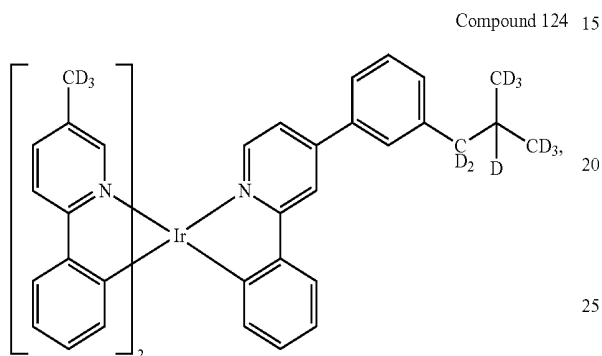
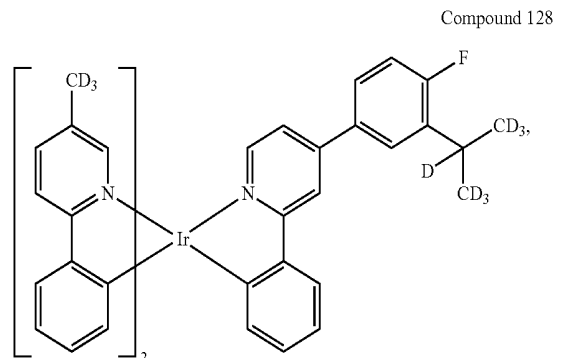
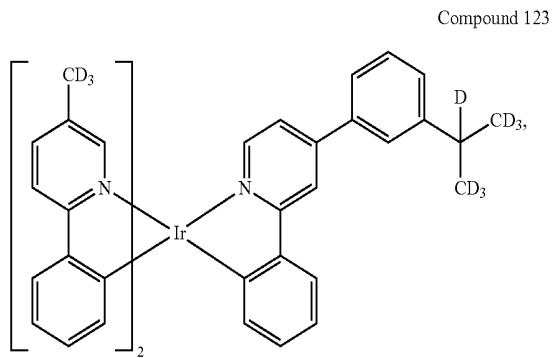

**113**  
-continued

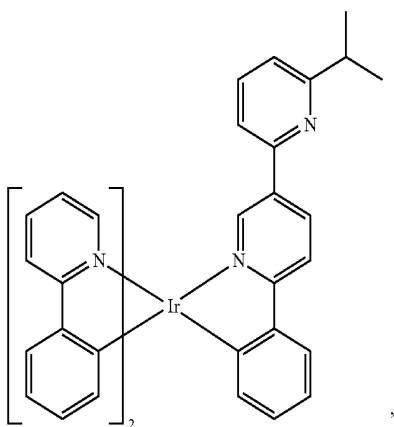
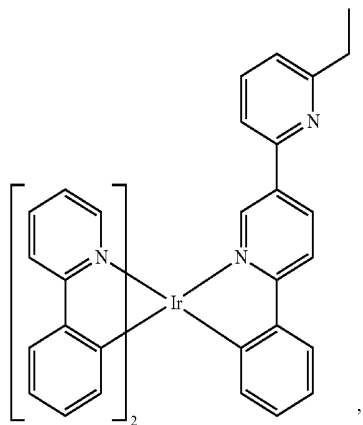
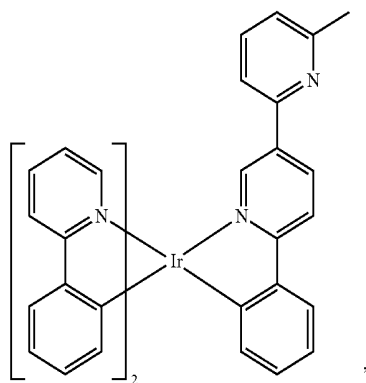
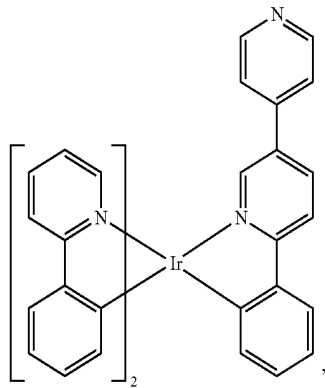

**114**  
-continued

Compound 132

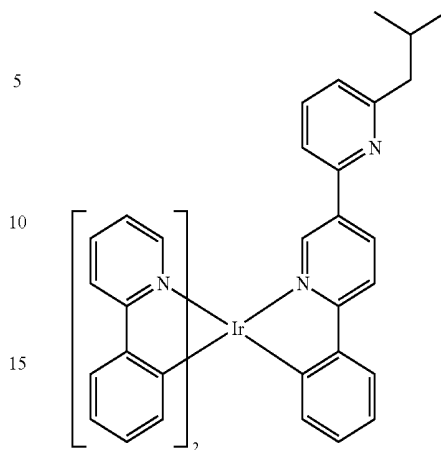

Compound 136

Compound 133

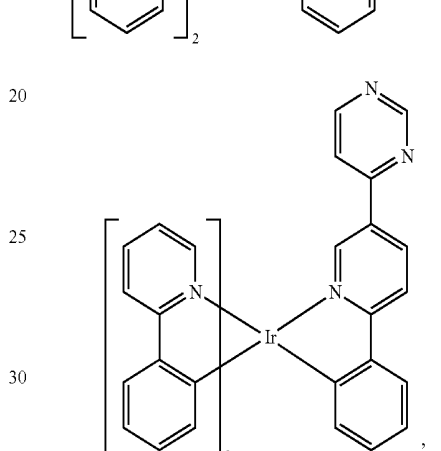

Compound 137

Compound 134

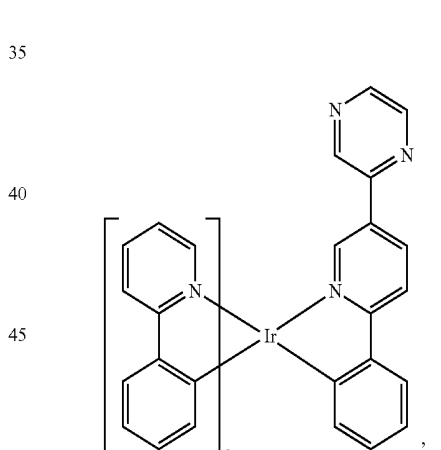

Compound 138

Compound 135

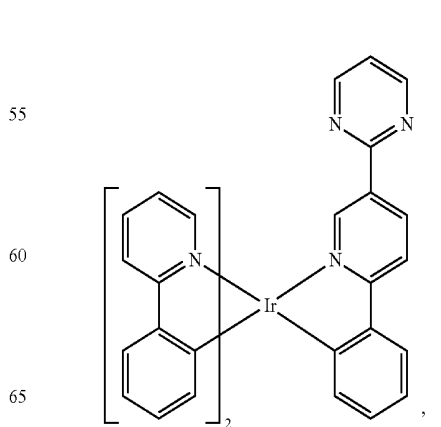

Compound 139

50

55

60

65

**115**  
-continued

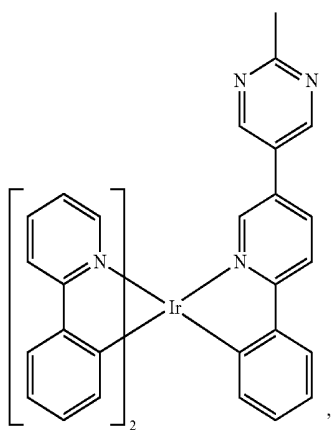
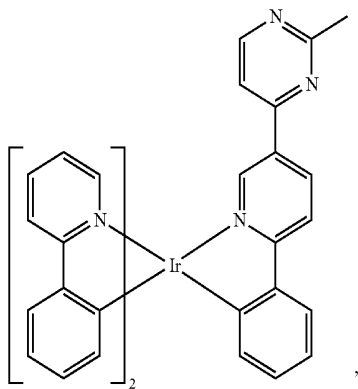
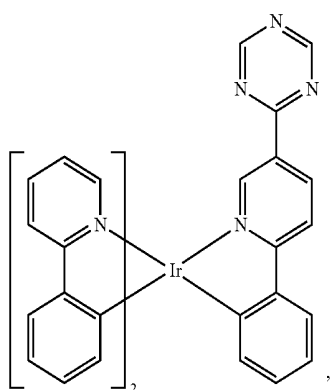
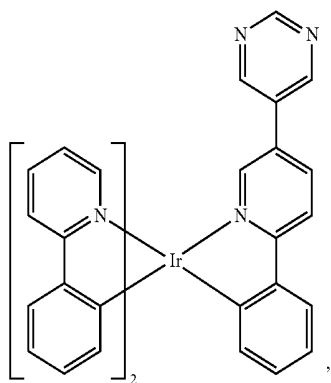

**116**  
-continued

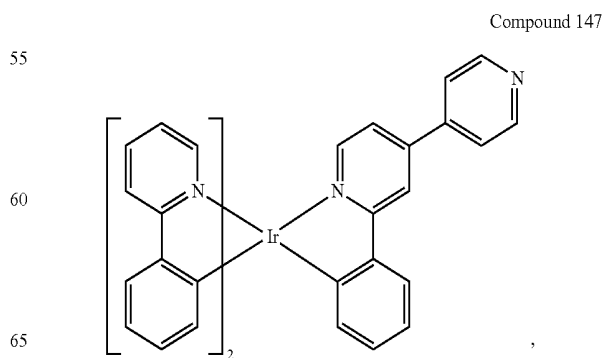
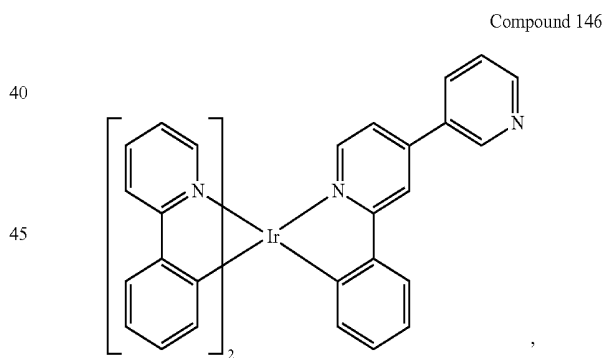
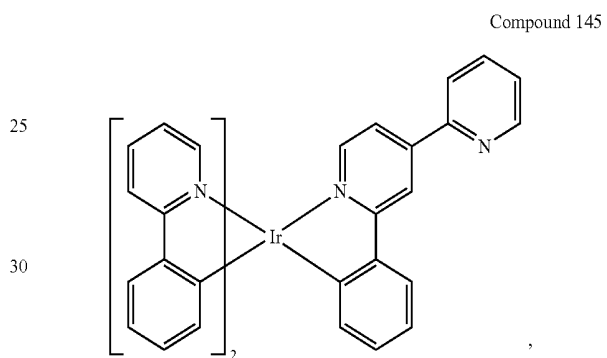
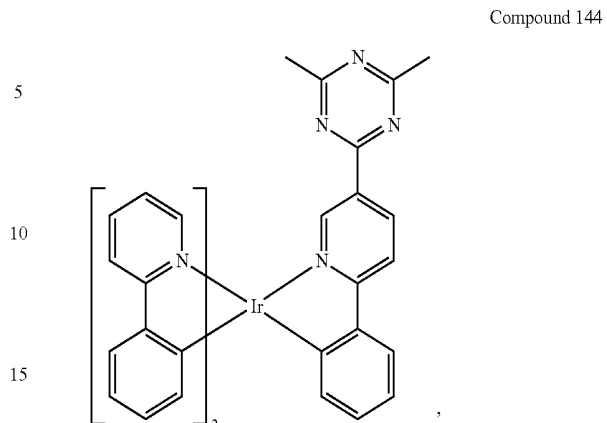

**117**  
-continued

**118**  
-continued

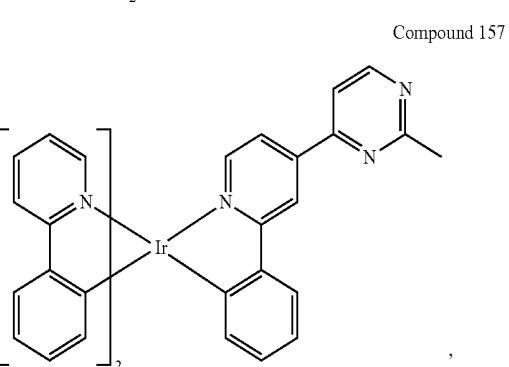
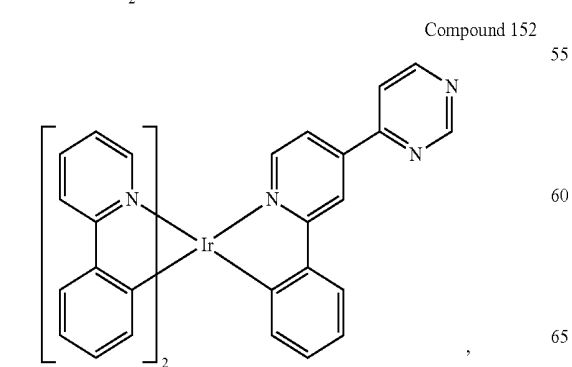
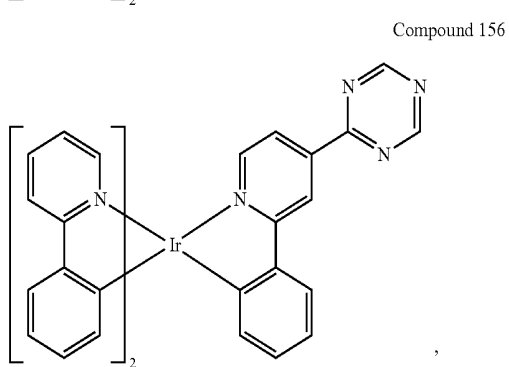
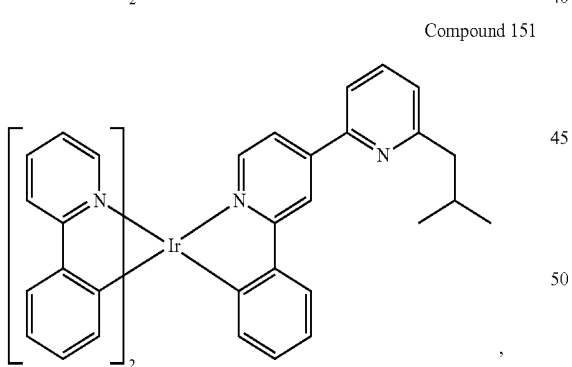
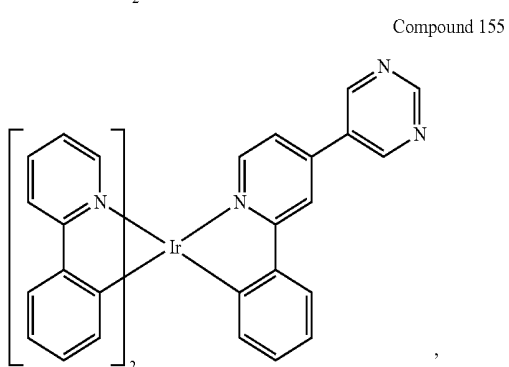
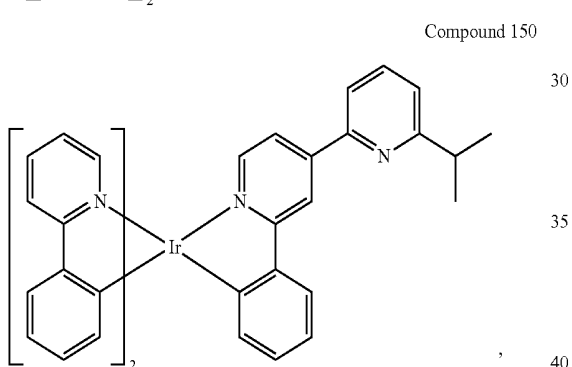
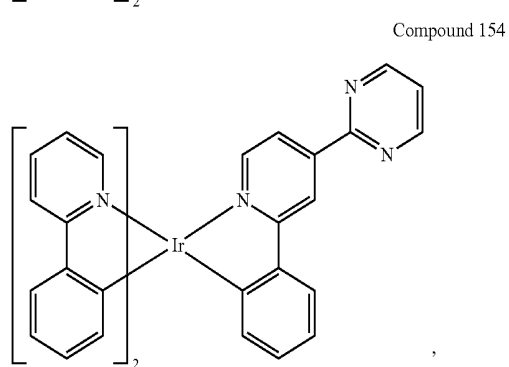
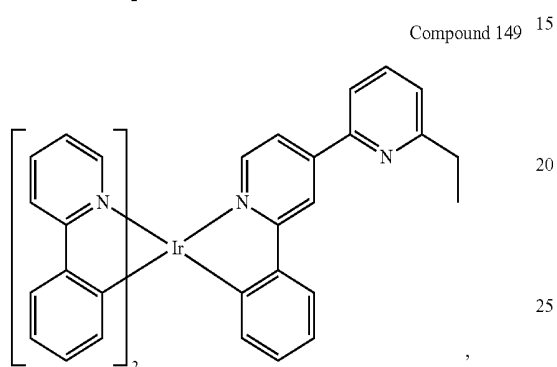
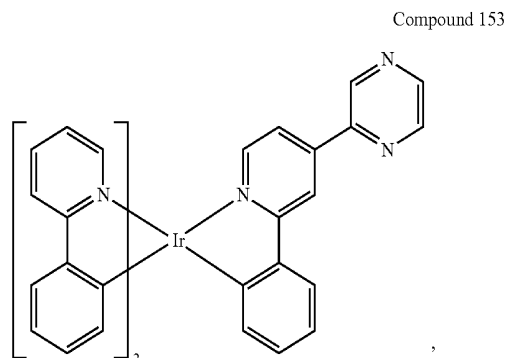
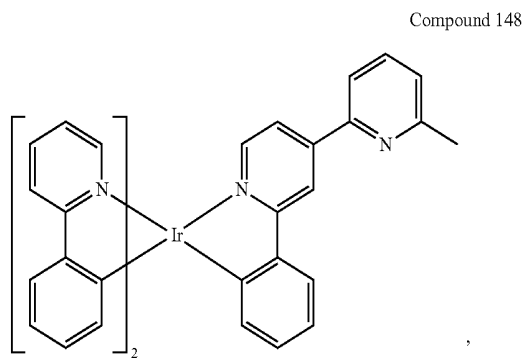

**119**  
-continued

**120**  
-continued

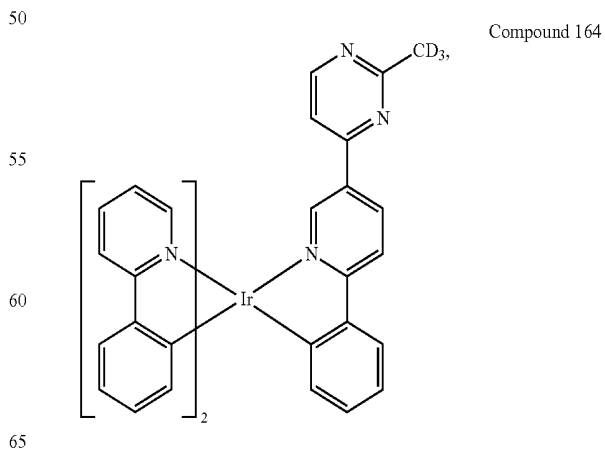
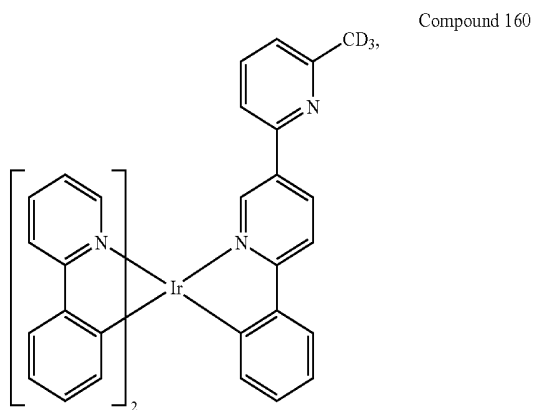
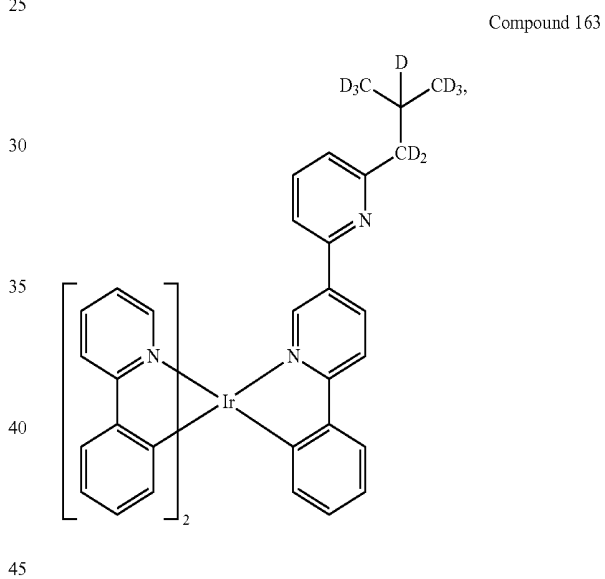
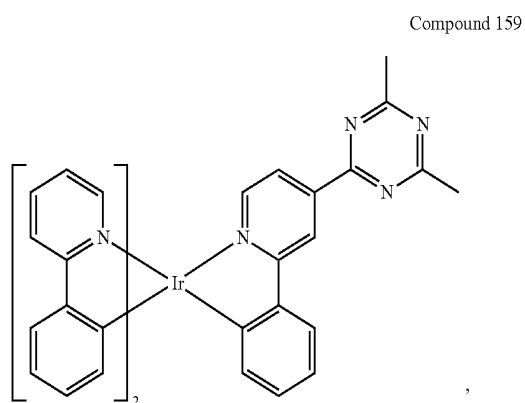
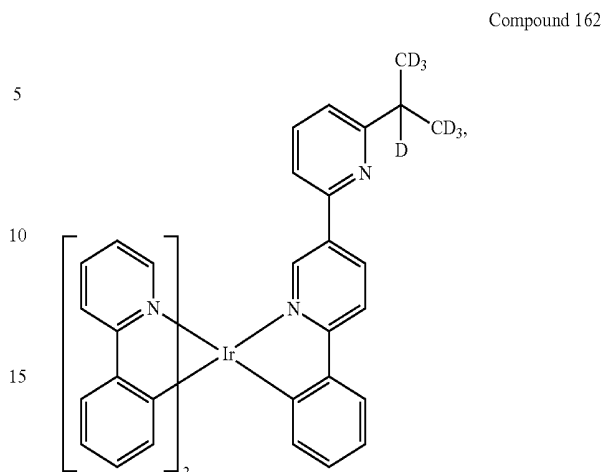
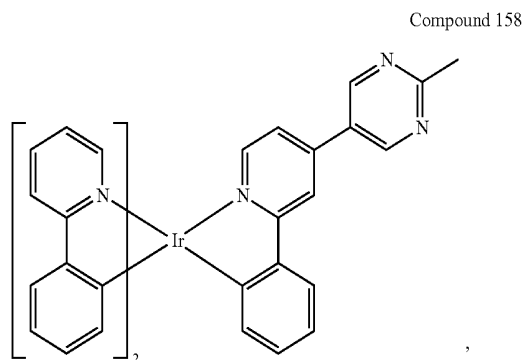

**121**  
-continued

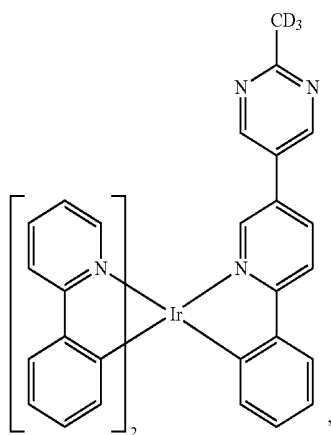

**122**  
-continued

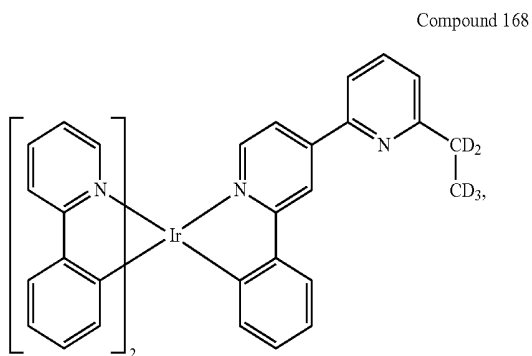
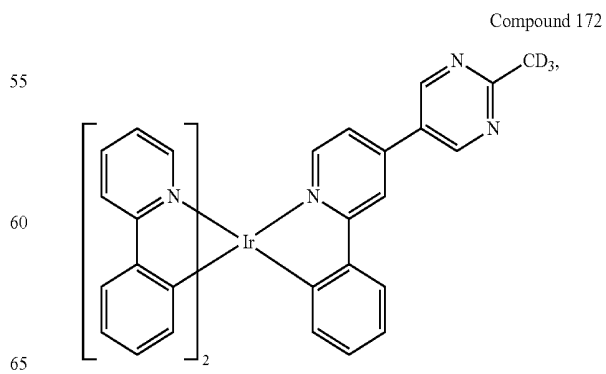
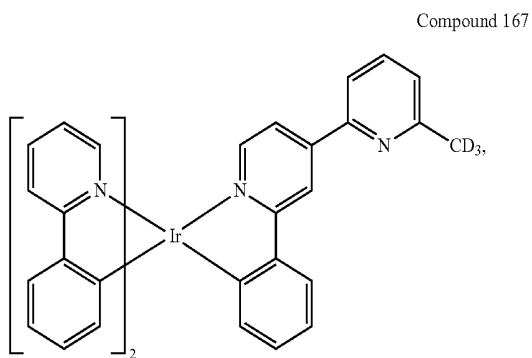
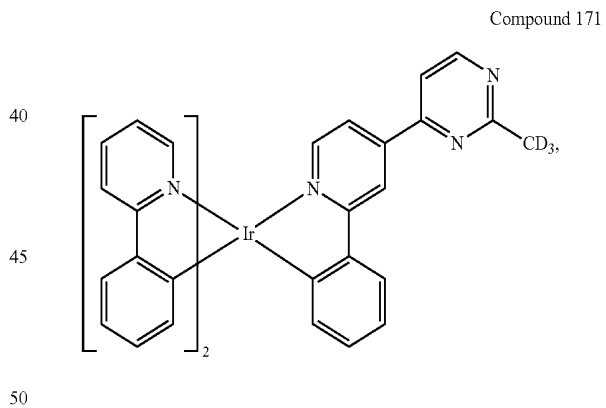
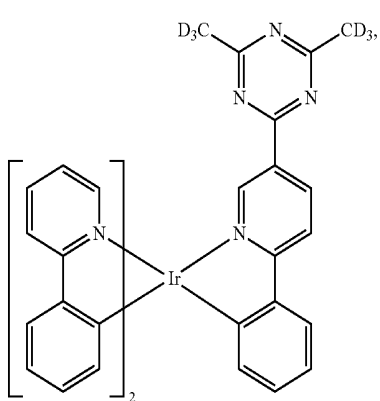
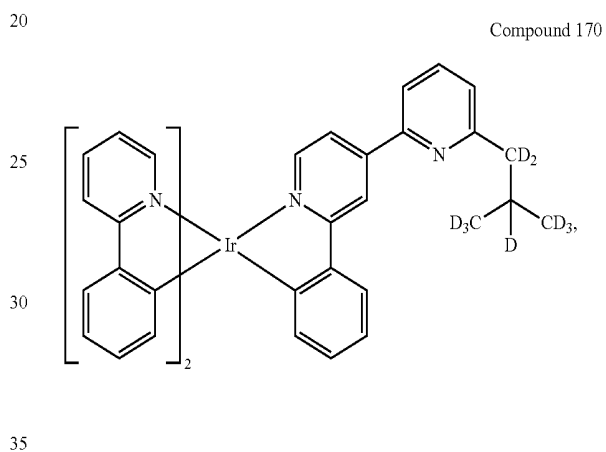
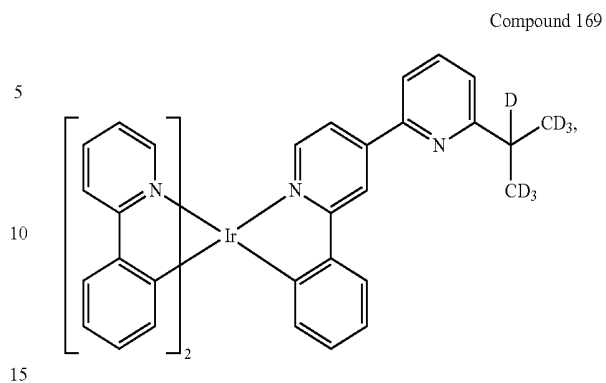

**123**  
-continued

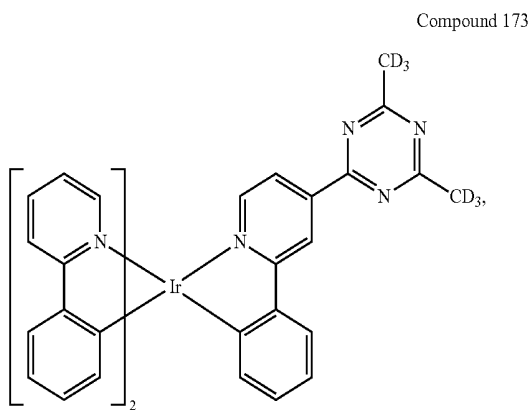

**124**  
-continued

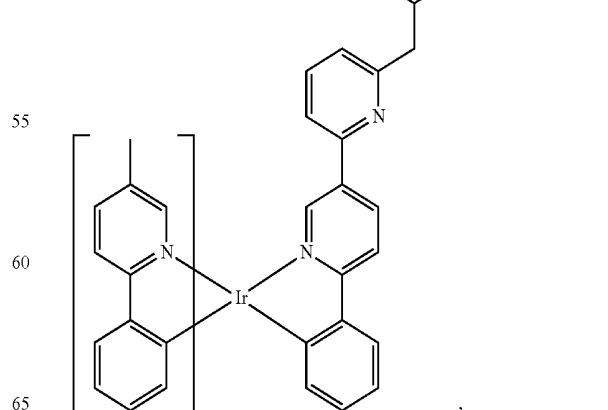
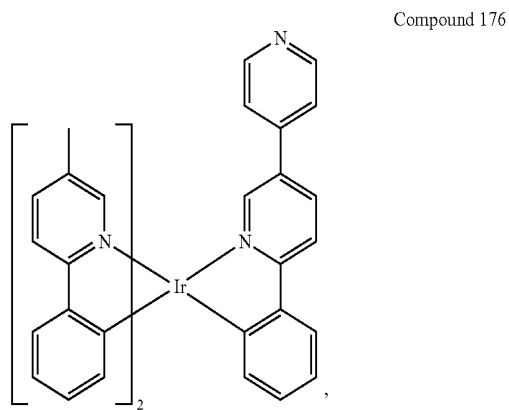
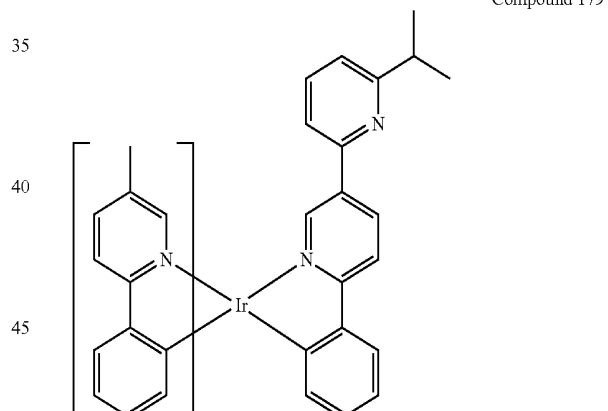
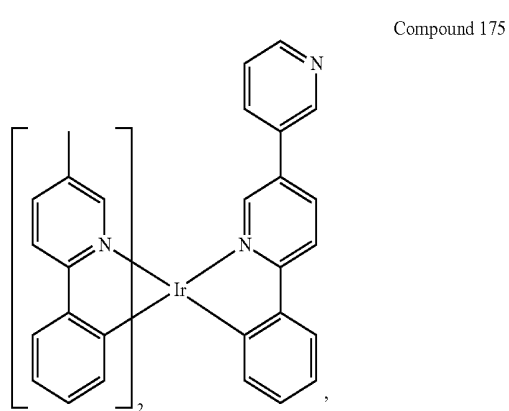
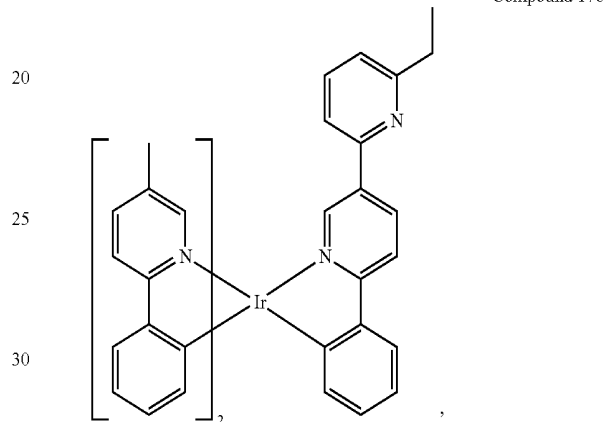
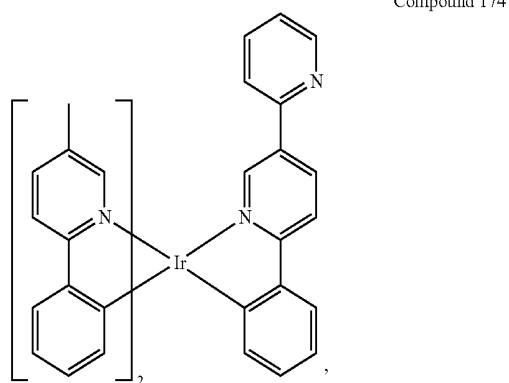
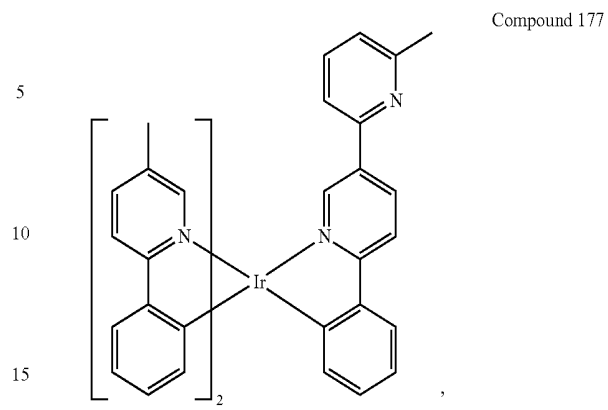

**125**  
-continued

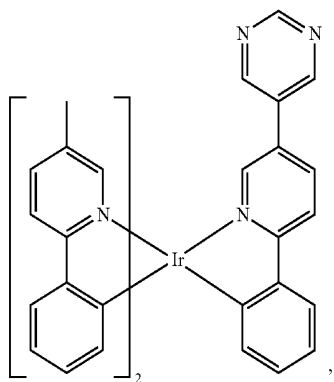
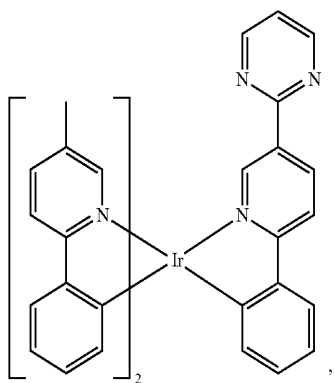
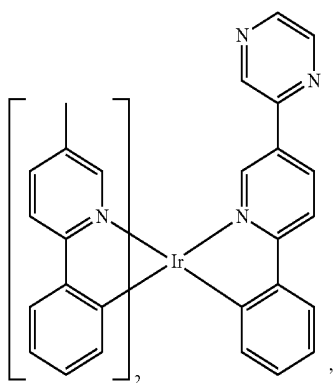
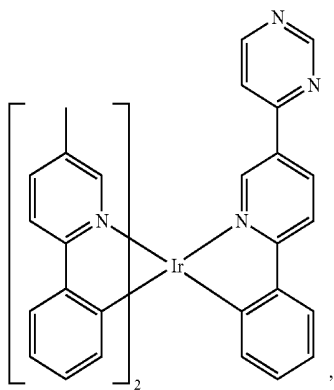

**126**  
-continued

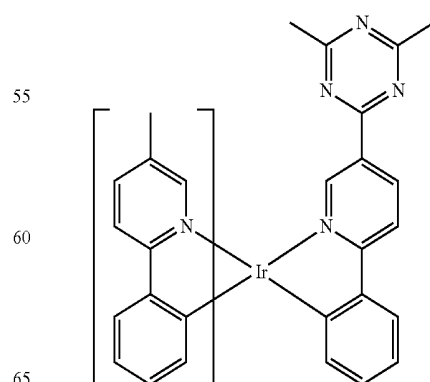
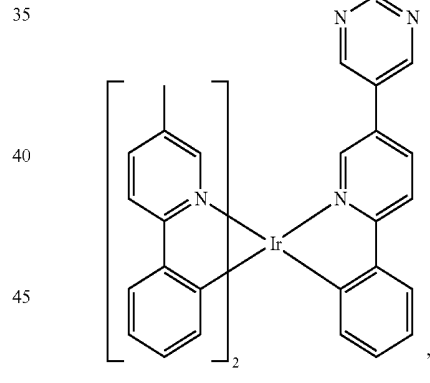
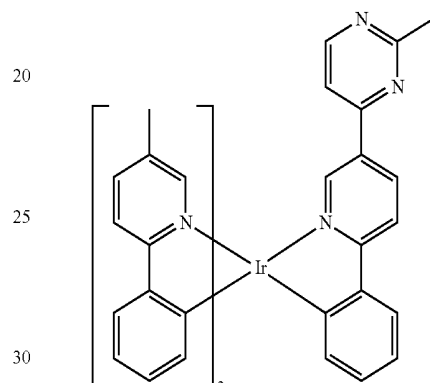
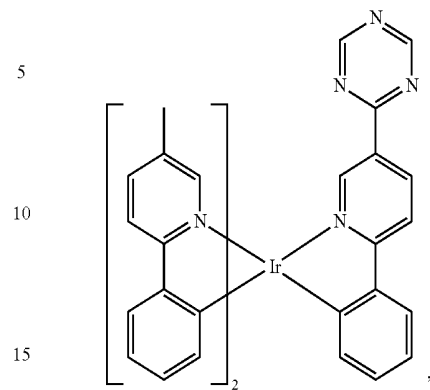

**127**  
-continued

**128**  
-continued

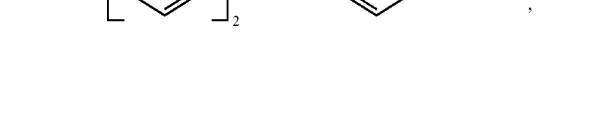
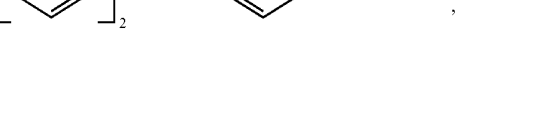
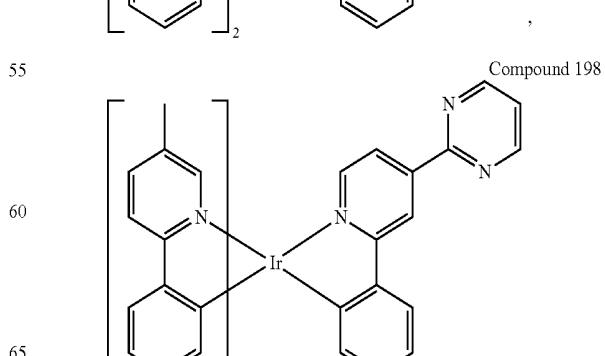
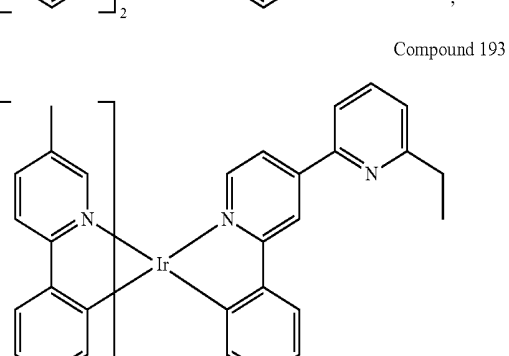
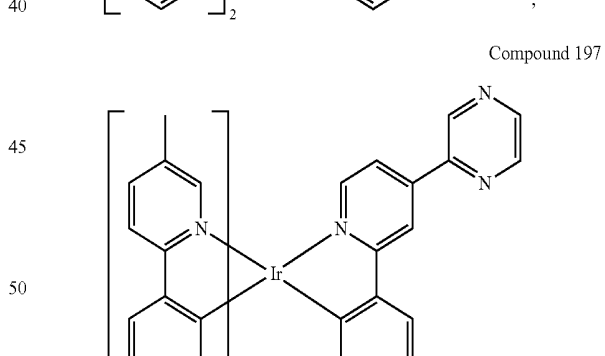
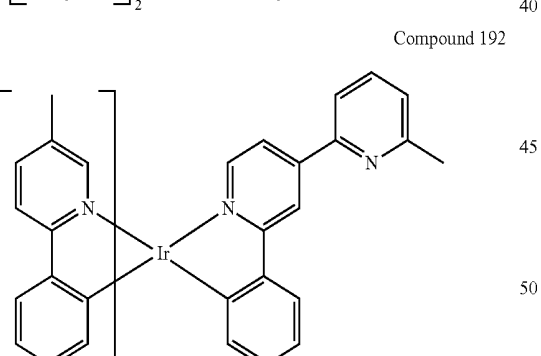
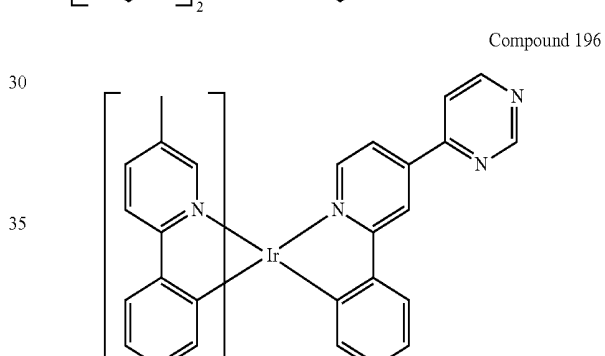
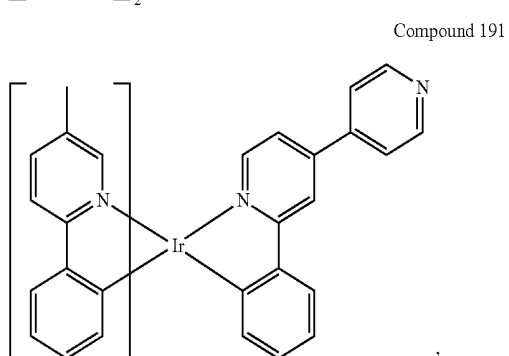
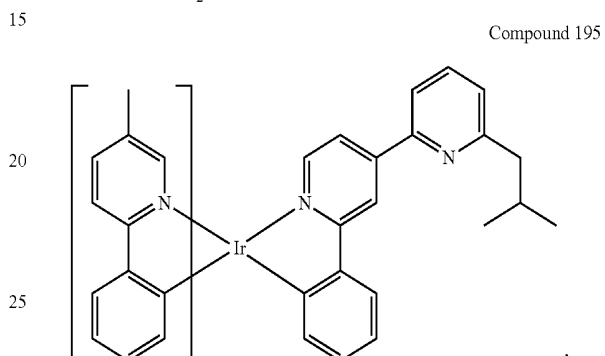
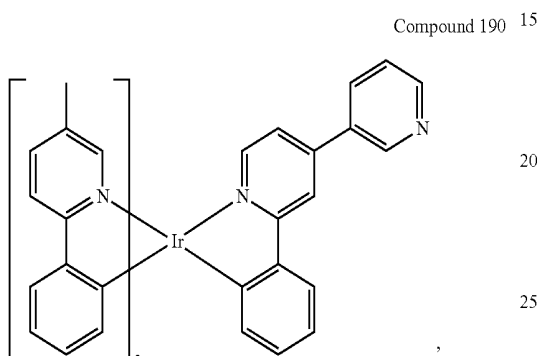
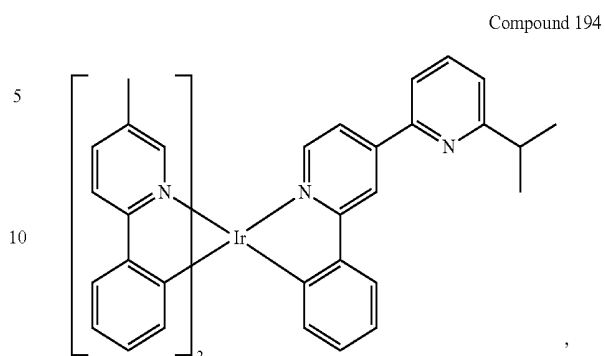
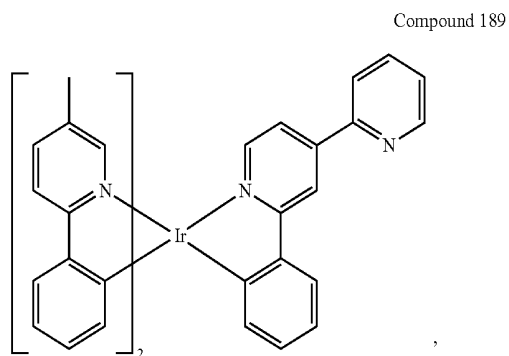

65

**129**  
-continued

**130**  
-continued

Compound 199

Compound 203

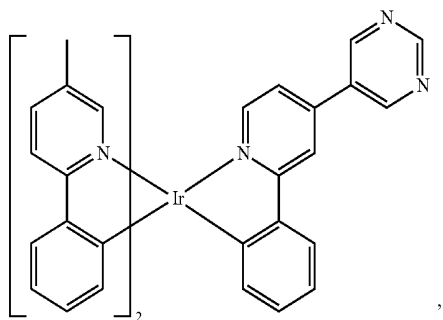

5

10

15

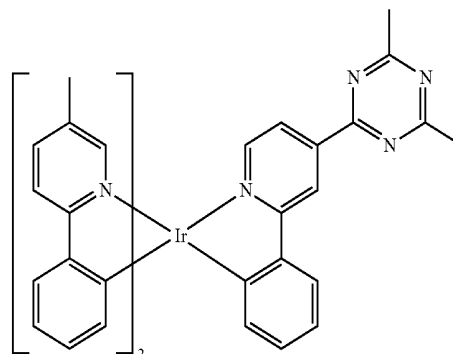

15

Compound 204

Compound 200

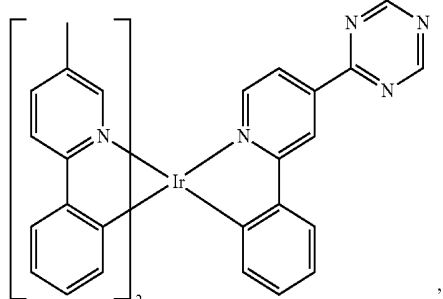

20

25

30

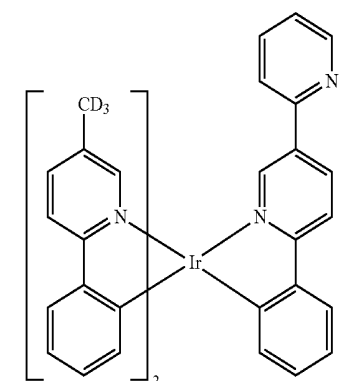

20

25

30

Compound 205

Compound 201

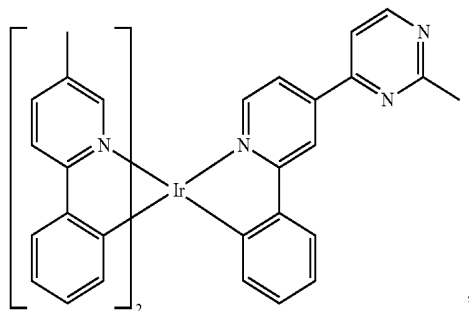

35

40

45

50

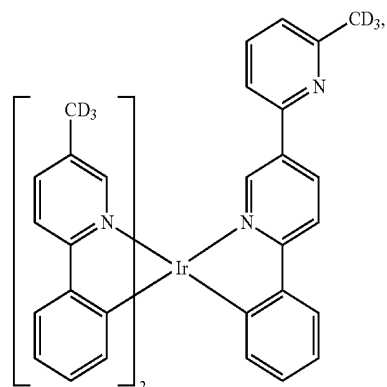

35

40

45

50

Compound 206

Compound 202

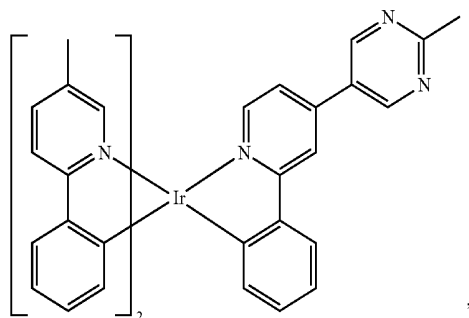

55

60

65

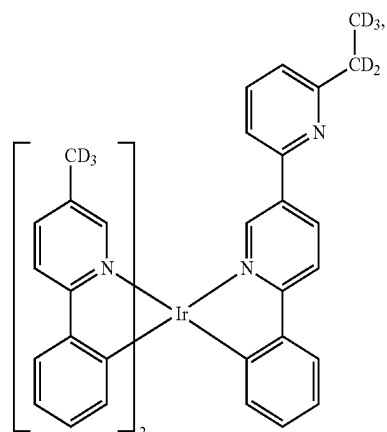

55

60

65

**131**  
-continued

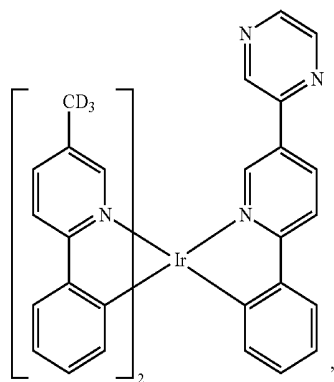
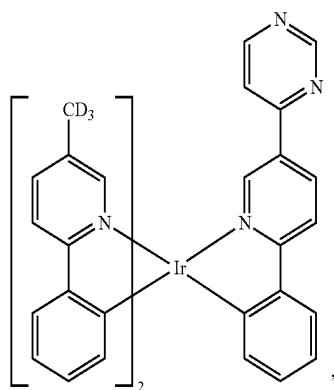
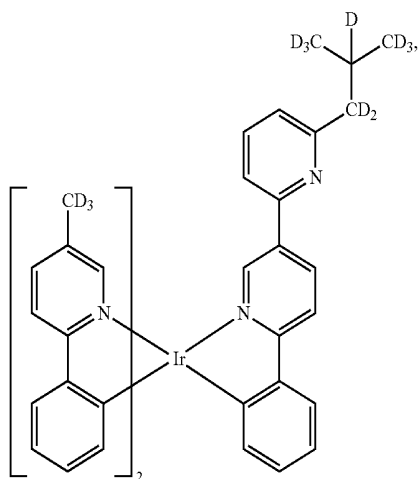
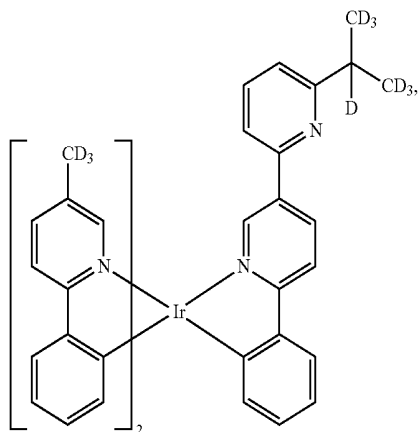

**132**  
-continued

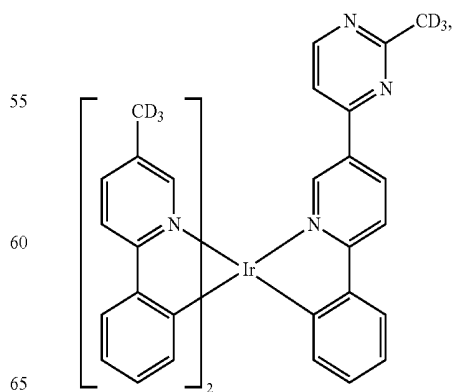
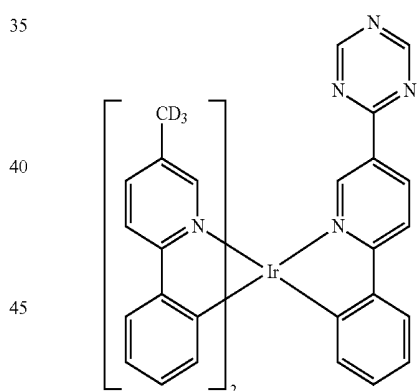
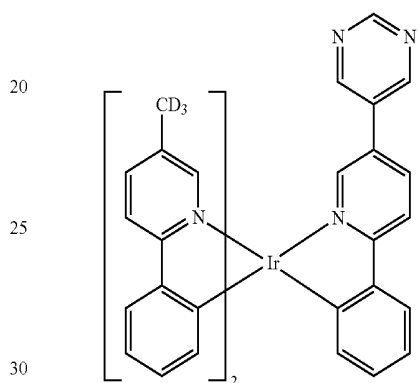
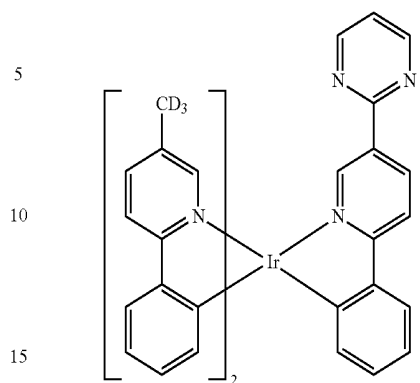

**133**  
-continued

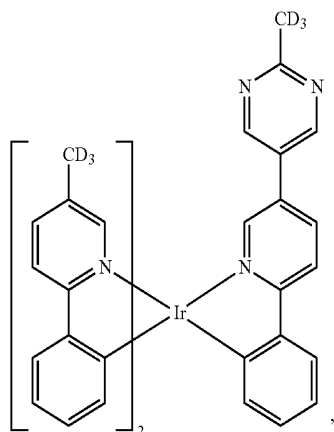

**134**  
-continued

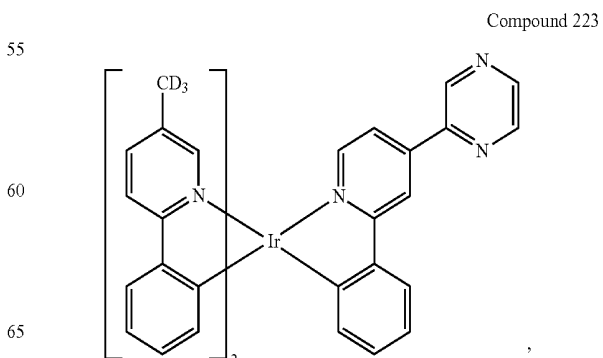
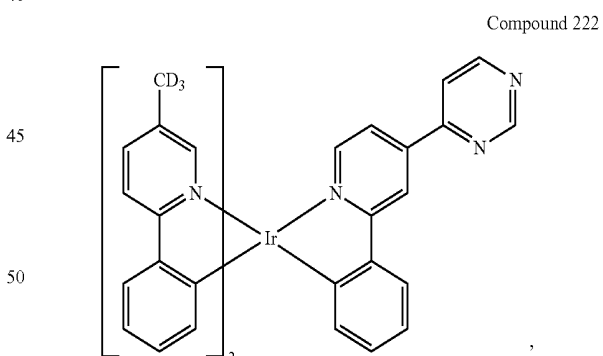
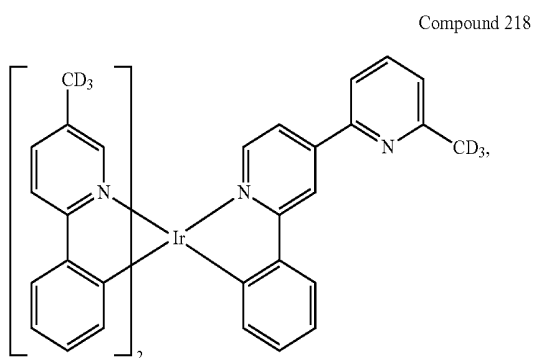
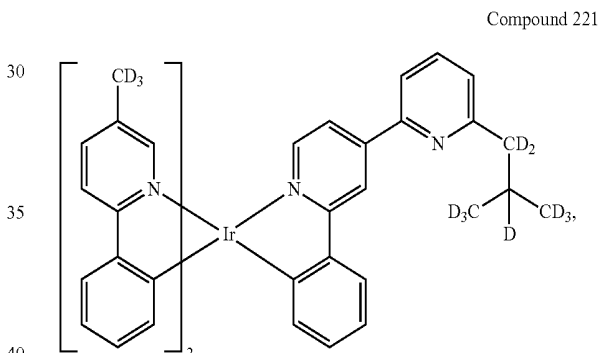
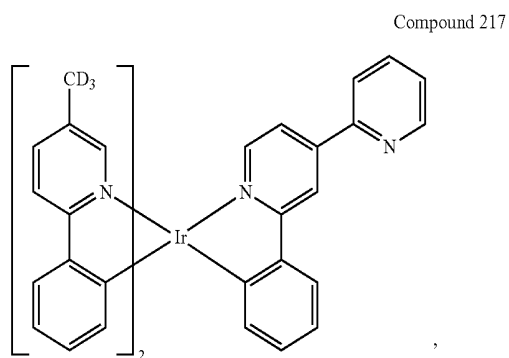
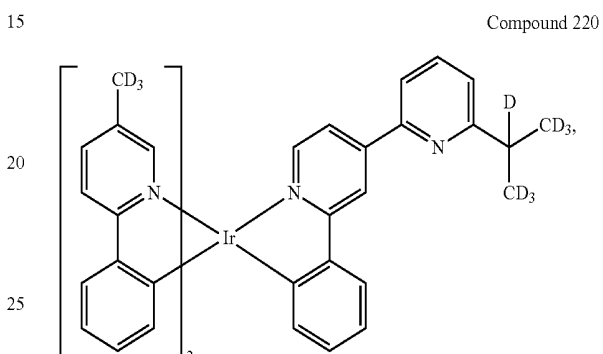
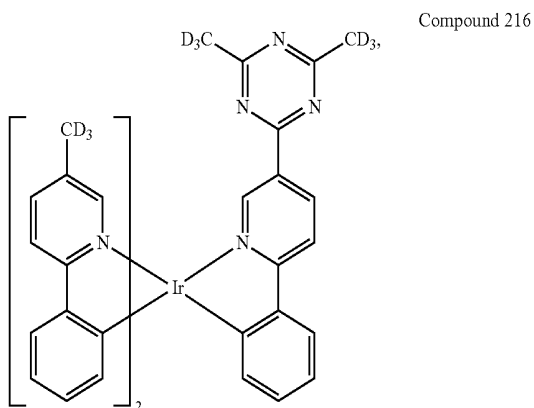
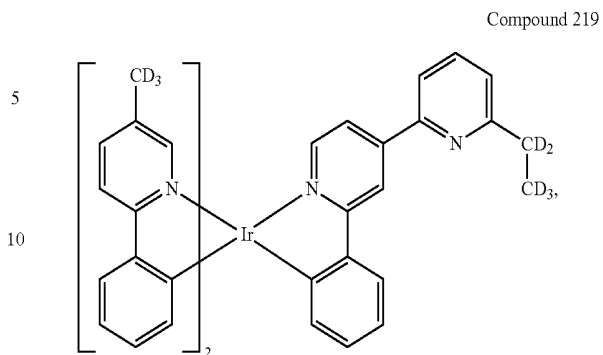

135

-continued

Compound 224

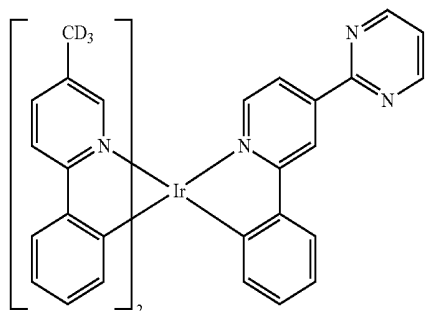

Compound 225 15

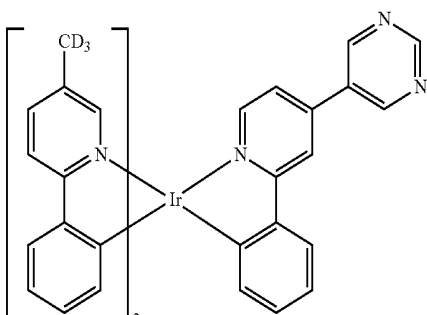

Compound 226

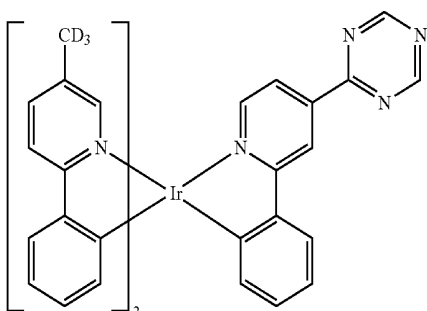

Compound 227

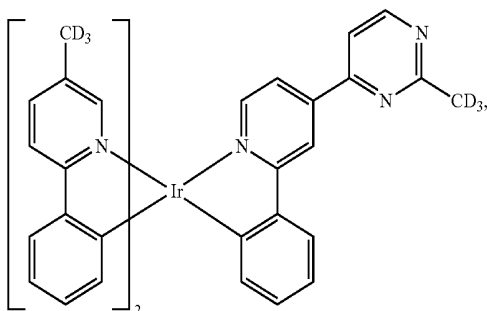

Compound 228

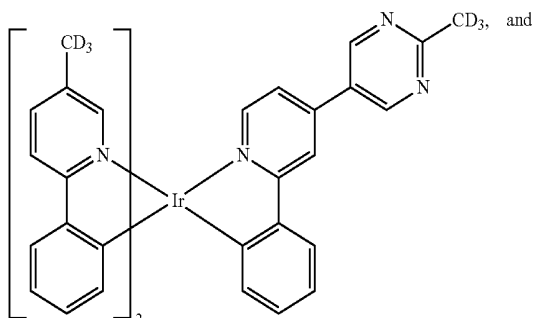

136

-continued

Compound 229

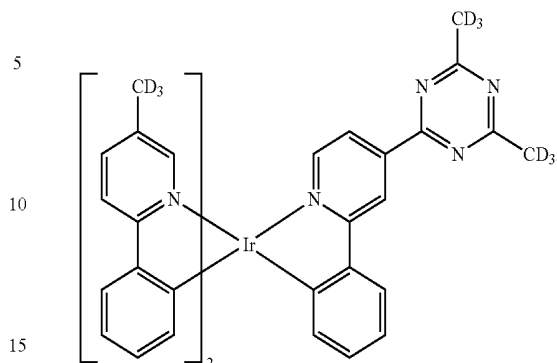

In one embodiment of the composition wherein the first compound and the second compound each independently has the formula of  $\text{Ir}(\text{L}^1)_2(\text{L}^2)$  as defined above, the mixture of the first compound and the second compound is selected from the group consisting of: (Compound 7 and Compound 130), (Compound 8 and Compound 131), (Compound 25 and Compound 131), (Compound 27 and Compound 135), (Compound 20 and Compound 145), (Compound 25 and Compound 148), (Compound 40 and Compound 174), (Compound 103 and Compound 204), and (Compound 116 and Compound 217).

In one embodiment of the composition comprising a mixture of a first compound and a second compound, wherein the first compound has a difference chemical structure than the second compound, wherein the first compound is capable of functioning as a phosphorescent emitter in an OLED at room temperature, the first compound has a structure according to Formula V:

Formula V

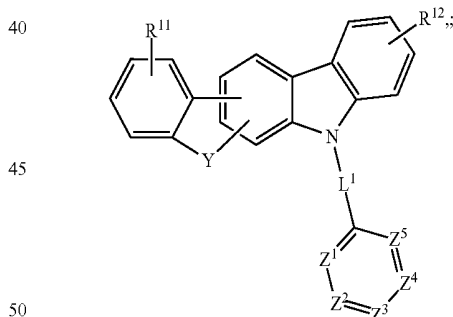

wherein  $\text{R}^{11}$  and  $\text{R}^{12}$  each independently represent mono, di, tri, tetra substitutions, or no substitution; Y is selected from the group consisting of O, S, Se,  $\text{NR}'$  and  $\text{CR}''\text{R}'''$ ;  $\text{L}^1$  is a single bond or comprises an aryl or heteroaryl group having from 5-24 carbon atoms, which is optionally further substituted;  $\text{Z}^1$ ,  $\text{Z}^2$ ,  $\text{Z}^3$ ,  $\text{Z}^4$  and  $\text{Z}^5$  are each independently selected from group consisting of  $\text{CR}''''$  and N; at least one of  $\text{Z}^1$ ,  $\text{Z}^2$ ,  $\text{Z}^3$ ,  $\text{Z}^4$  and  $\text{Z}^5$  is N; and  $\text{R}^{11}$ ,  $\text{R}^{12}$ ,  $\text{R}'$ ,  $\text{R}''$ ,  $\text{R}'''$  and  $\text{R}''''$  are each independently selected from the group consisting of hydrogen, deuterium, halide, alkyl, cycloalkyl, heteroalkyl, arylalkyl, alkoxy, aryloxy, amino, alkenyl, cycloalkenyl, heteroalkenyl, alkynyl,

137

aryl, heteroaryl, acyl, carbonyl, carboxylic acid, ester, nitrile, isonitrile, sulfanyl, sulfinyl, sulfonyl, phosphino, and combinations thereof; wherein the second compound has the Formula VI:

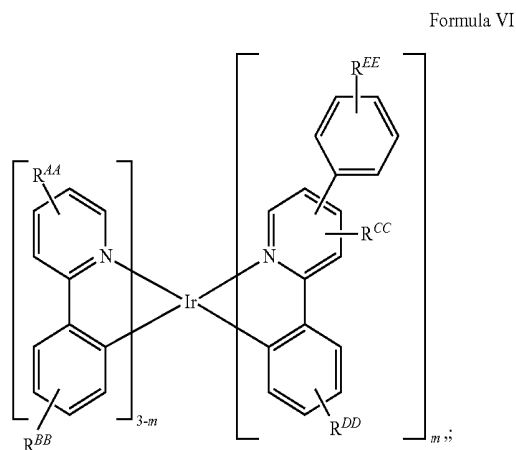

wherein  $R^{AA}$ ,  $R^{BB}$ ,  $R^{DD}$ , and  $R^{EE}$  each independently represent mono, di, tri, tetra substitutions, or no substitution;  $R^{CC}$  represent mono, di, tri substitutions, or no substitution;  $R^{AA}$ ,  $R^{BB}$ ,  $R^{CC}$ ,  $R^{DD}$ , and  $R^{EE}$  are each independently selected from the group consisting of hydrogen, deuterium, halide, alkyl, cycloalkyl, heteroalkyl, arylalkyl, alkoxy, aryloxy, amino, silyl, alkenyl, cycloalkenyl, heteroalkenyl, alkynyl, aryl, heteroaryl, acyl, carbonyl, carboxylic acid, ester, nitrite, isonitrile, sulfinyl, sulfonyl, phosphino, and combinations thereof; and  $m$  is 1 or 2.

In one embodiment, where the second compound has the structure according to Formula II defined above,  $X^1$ ,  $X^3$  and  $X^5$  are N; and  $X^2$  and  $X^4$  are  $CR^{mm}$ .

In one embodiment, where the second compound has the structure according to Formula VI,  $m$  is 1. In another embodiment,  $R^{AA}$ ,  $R^{BB}$ ,  $R^{CC}$ , and  $R^{DD}$  are each independently selected from the group consisting of hydrogen, deuterium, alkyl, cycloalkyl, and combinations thereof. In another embodiment,  $R^{EE}$  is selected from the group consisting of hydrogen, deuterium, halide, alkyl, cycloalkyl, and combinations thereof.

In another embodiment, where the second compound has the structure according to Formula VI defined above, the second compound is selected from the group consisting of:

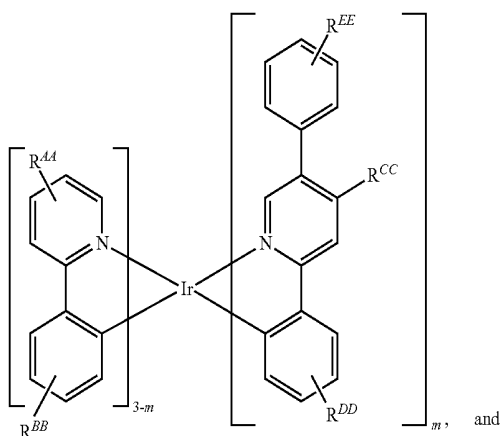

138

-continued

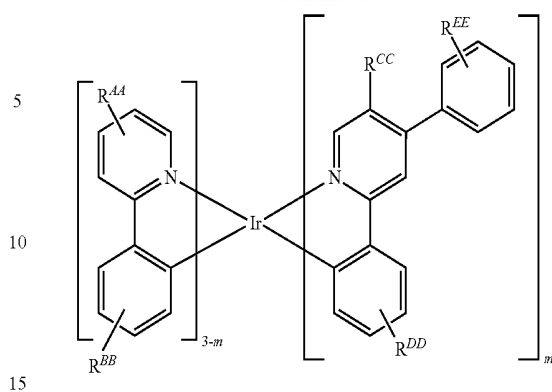

In another embodiment, where the first compound has the structure according to Formula V defined above, the first compound is selected from the group consisting of:

Compound EH1

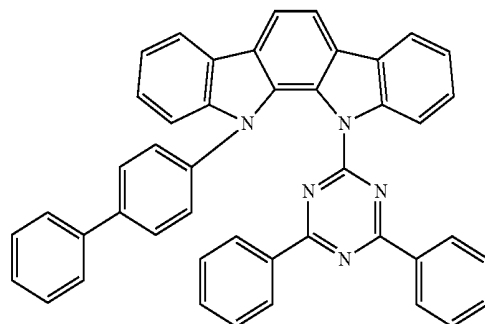

Compound EH2

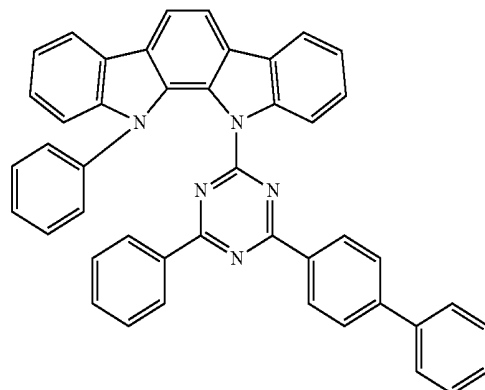

Compound EH3

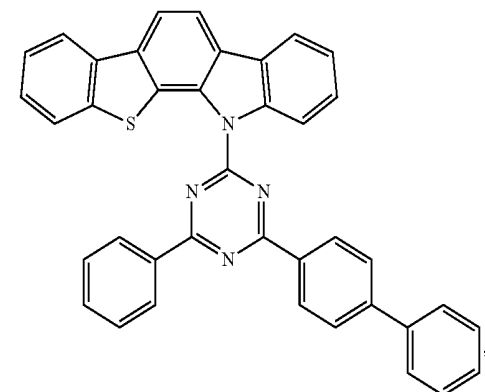

**139**  
-continued

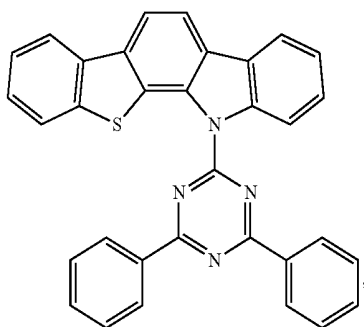

Compound EH4

5

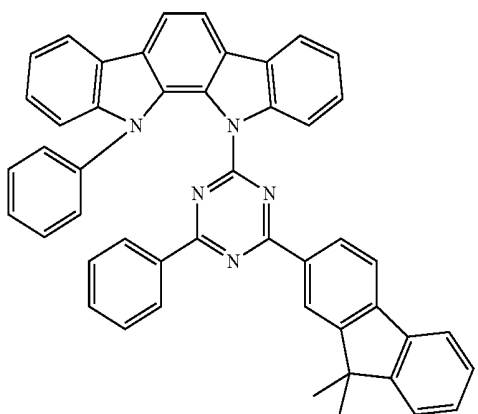

Compound EH5

15

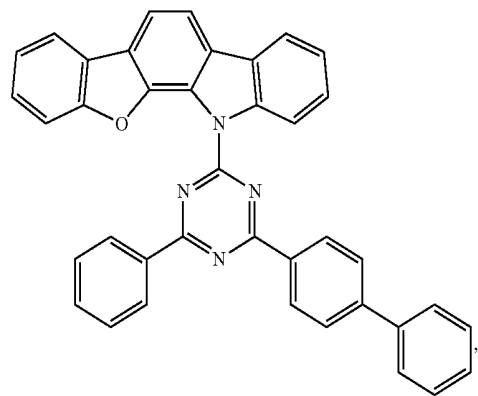

Compound EH6

25

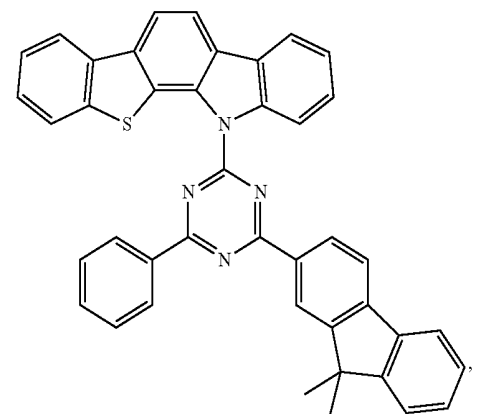

Compound EH7

50

**140**  
-continued

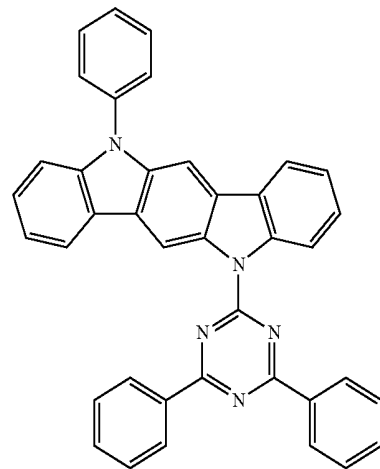

Compound EH8

10

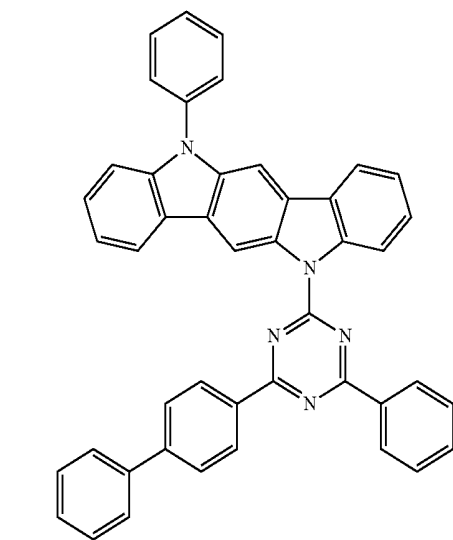

Compound EH9

30

35

40

45

50

55

60

65

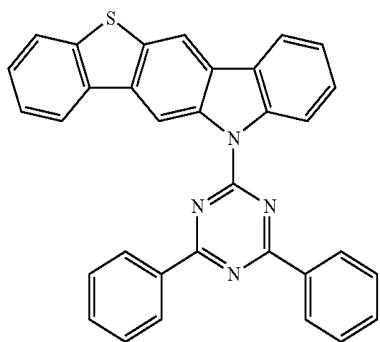

Compound EH10

**141**  
-continued

Compound EH11

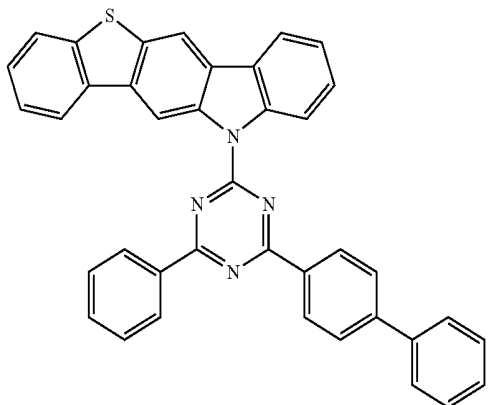

Compound EH12

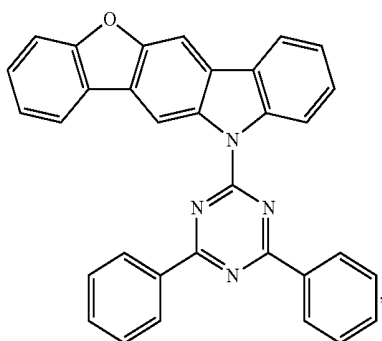

Compound EH13

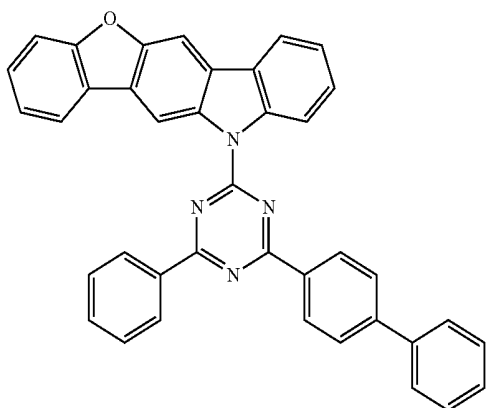

Compound EH14

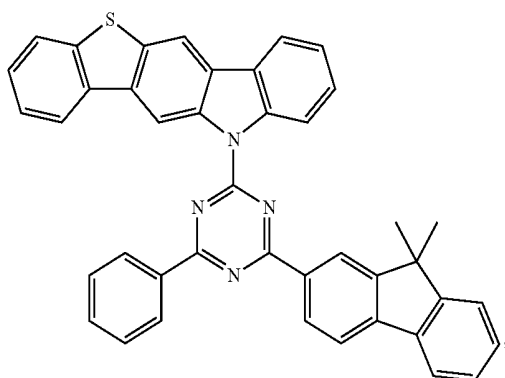

**142**  
-continued

Compound EH15

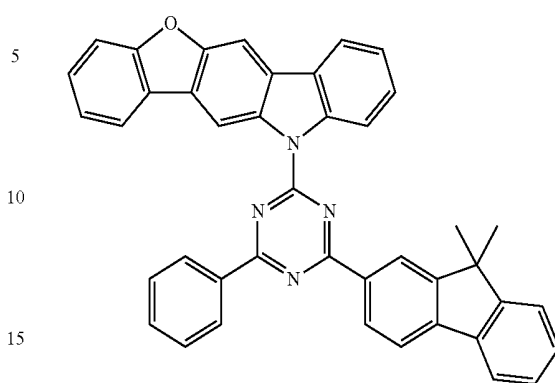

20

Compound EH16

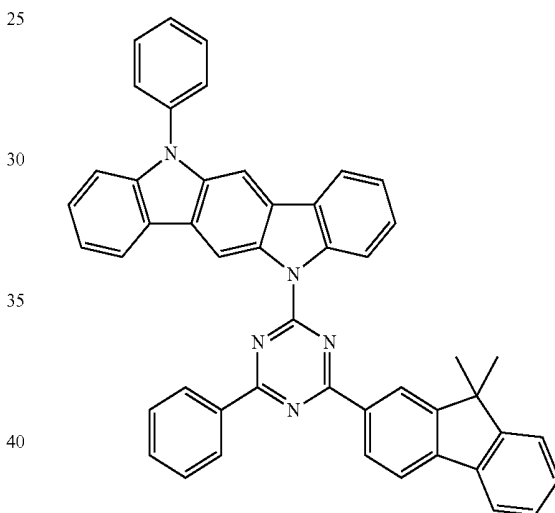

40

45

Compound EH17

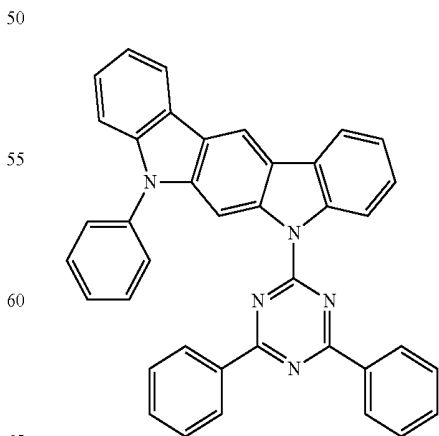

65

**143**  
-continued

Compound EH18

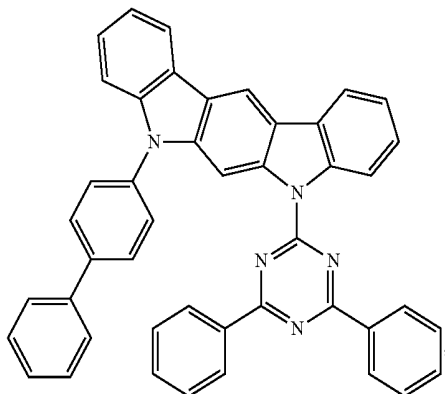

5

10

15

20

**144**  
-continued

Compound EH21

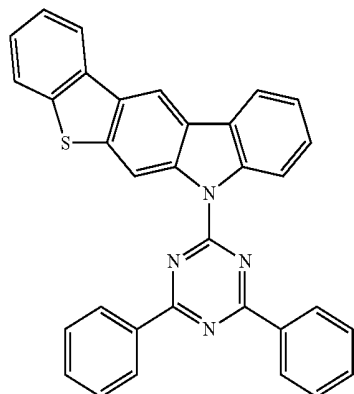

25

30

35

40

45

Compound EH19

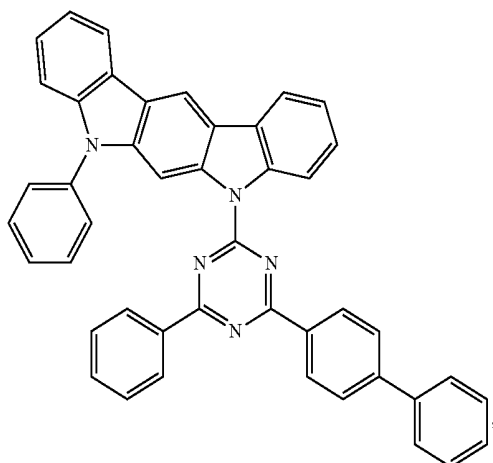

50

55

60

65

Compound EH22

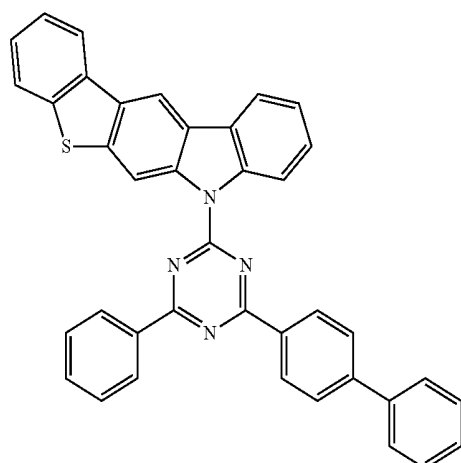

Compound EH23

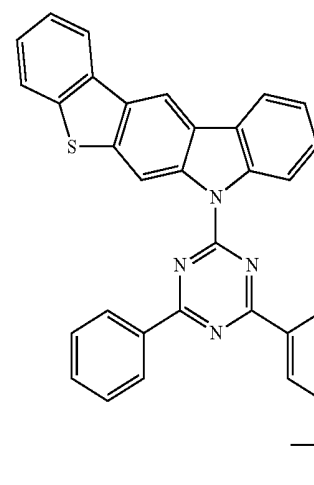
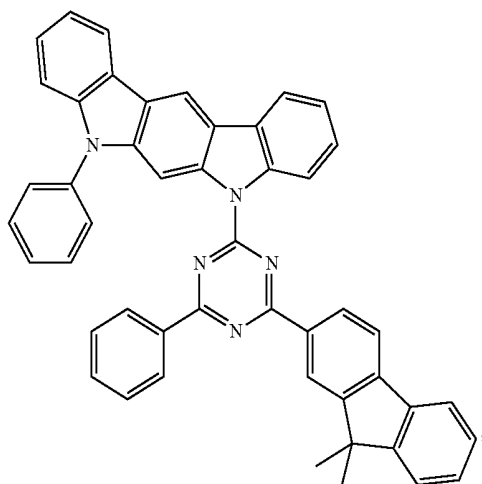

**145**  
-continued

Compound EH24

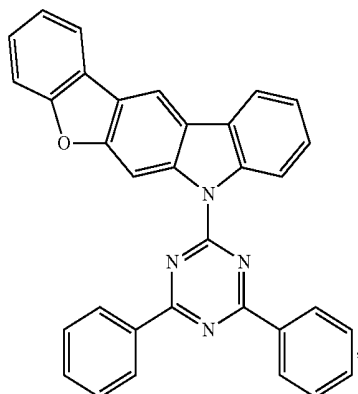

5

10

15

20

**146**  
-continued

Compound EH27

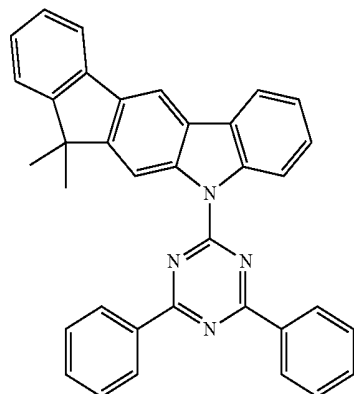

25

30

35

40

45

Compound EH25

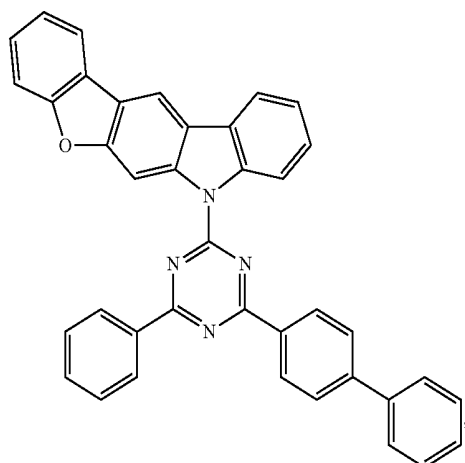

50

55

60

65

Compound EH28

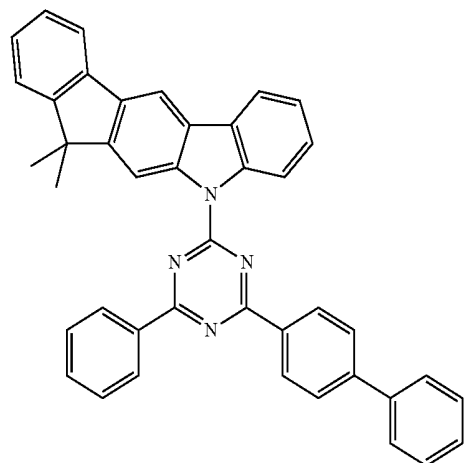

Compound EH26

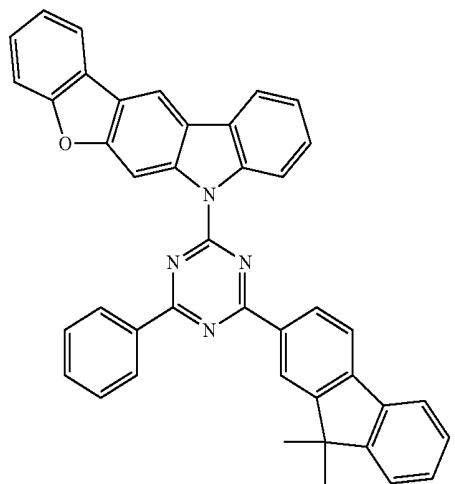

Compound EH29

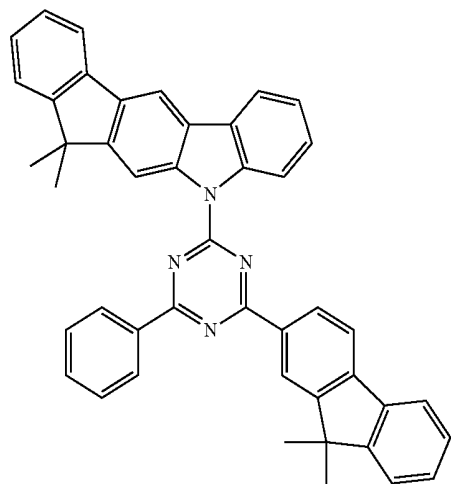

**147**  
-continued

**148**  
-continued

Compound EH30

Compound EH33

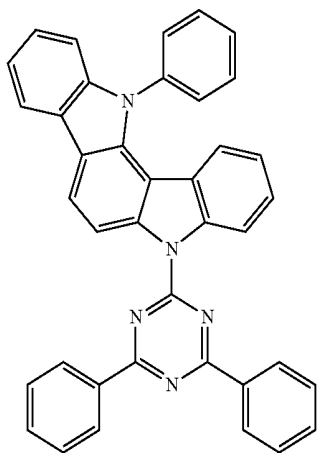

5

10

15

20

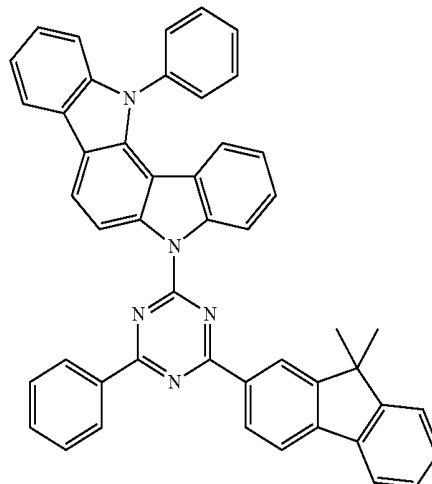

Compound EH31

Compound EH34

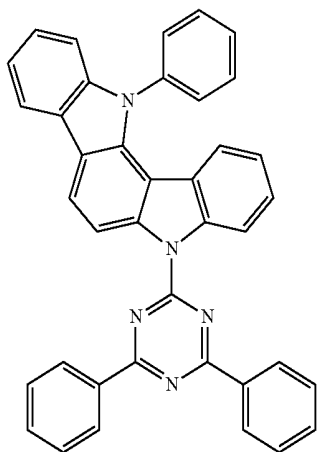

25

30

35

40

45

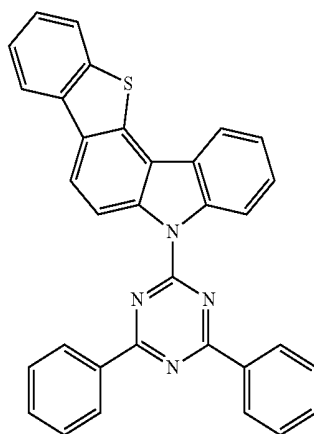

Compound EH32

Compound EH35

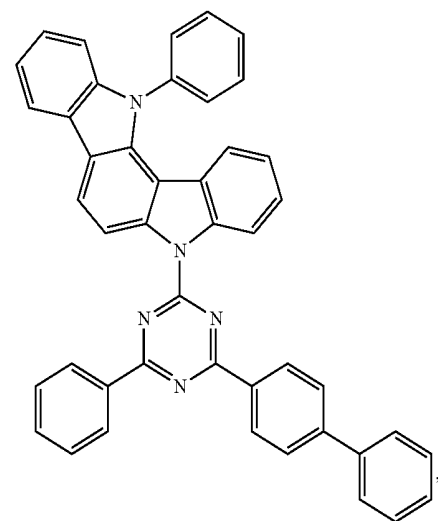

50

55

60

65

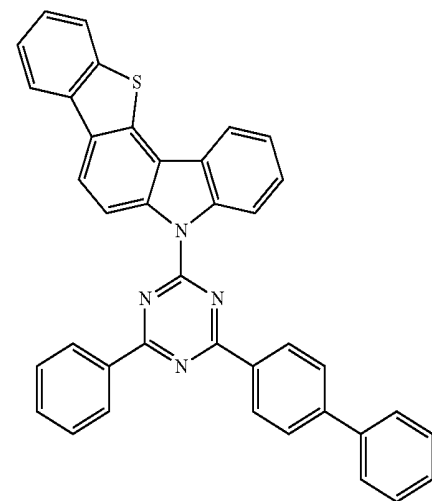

149  
-continued

Compound EH36

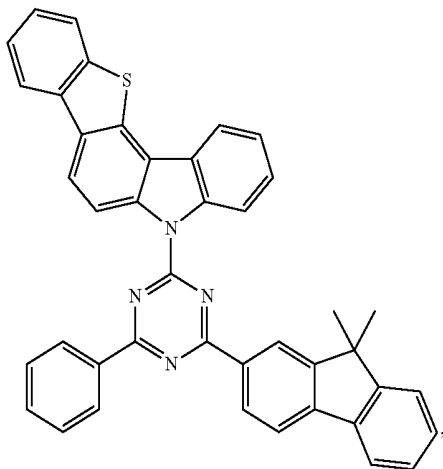

5

150  
-continued

Compound EH39

10

15

20

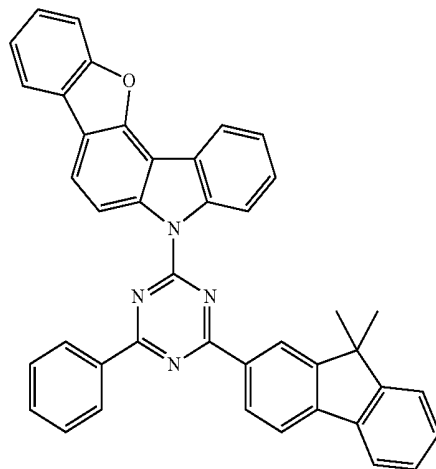

25

Compound EH37

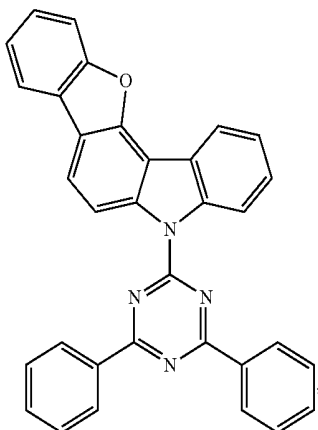

30

Compound EH40

35

40

45

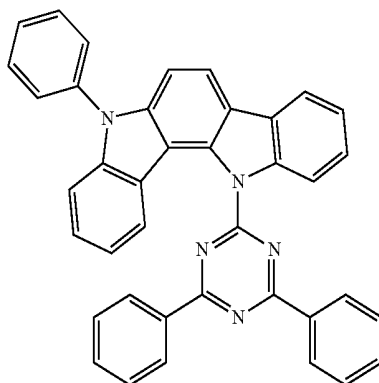

Compound EH38

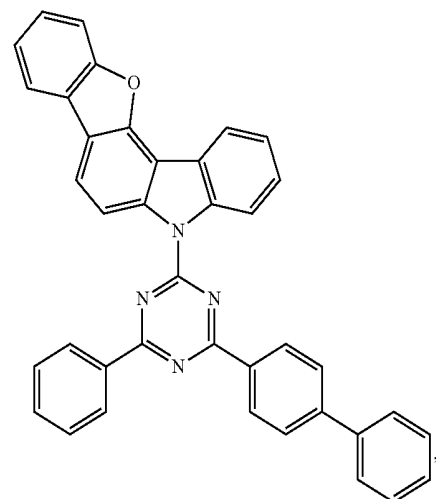

50

Compound EH41

55

60

65

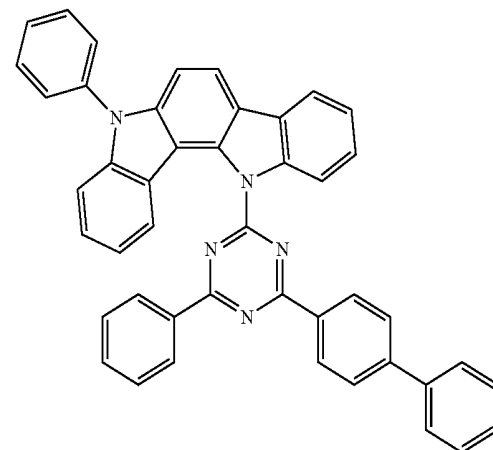

**151**  
-continued

Compound EH42

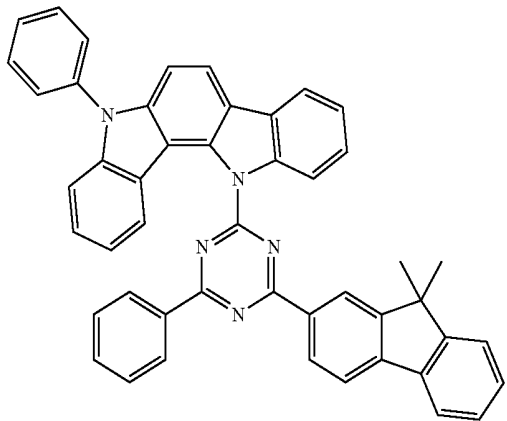

Compound EH43

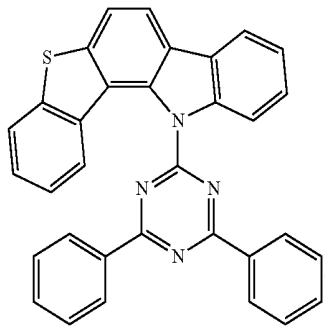

Compound EH44

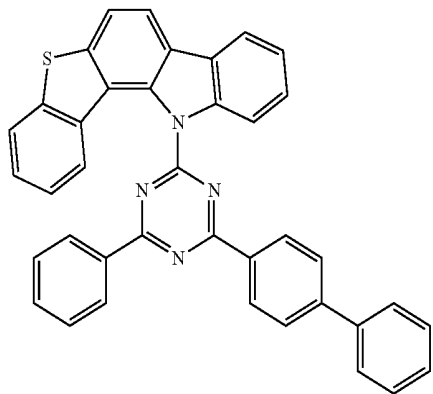

Compound EH45

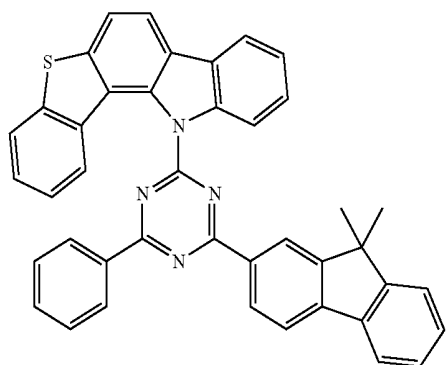

**152**  
-continued

Compound EH46

5

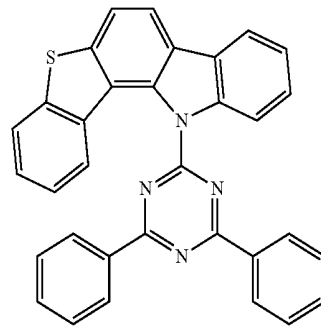

10

15

Compound EH47

20

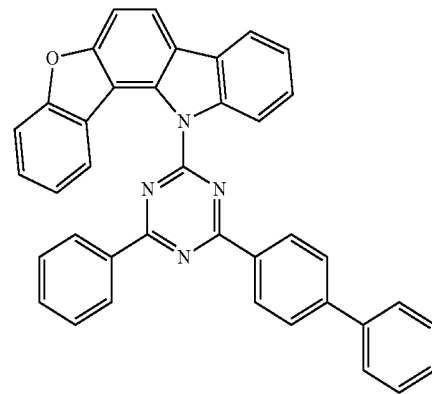

25

30

Compound EH48

35

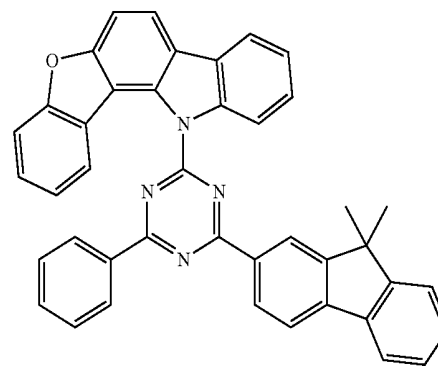

40

45

50

Compound EH49

55

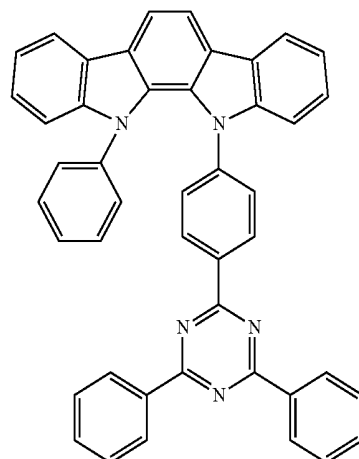

60

65

**153**  
-continued

Compound EH50

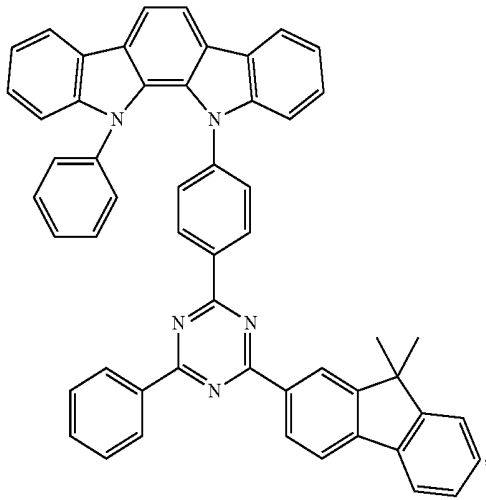

5

10

15

20

25

Compound EH51

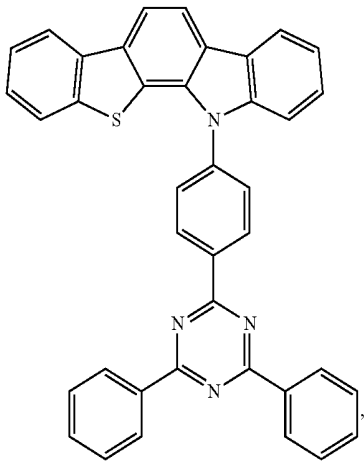

30

35

40

45

Compound EH52

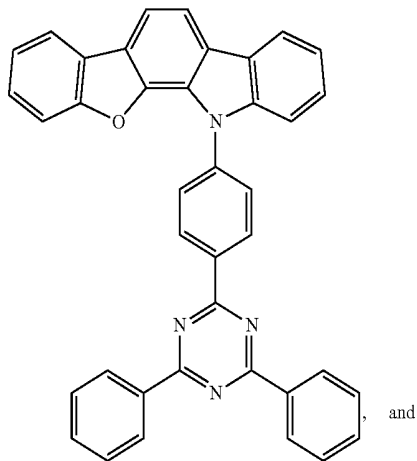

50

55

60

65

**154**  
-continued

Compound EH53

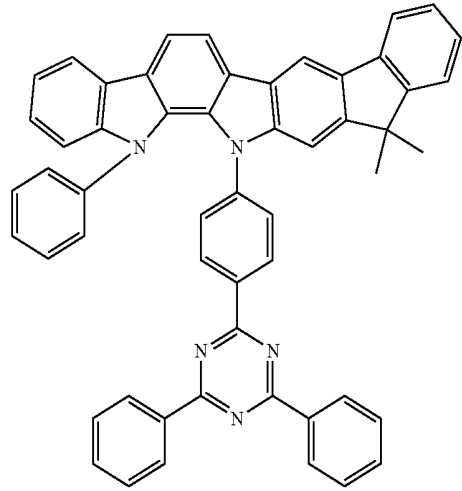

5

10

15

20

25

In one embodiment of the composition, where the second compound has the structure according to Formula VI, the second compound is selected from the group consisting of:

30

35

40

45

Compound 1

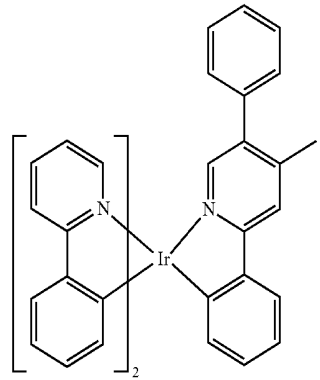

50

55

60

65

Compound 2

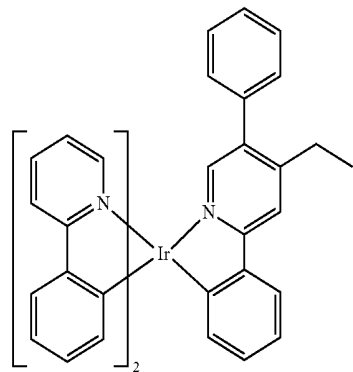

**155**  
-continued

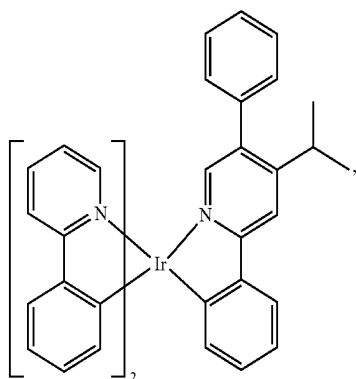

Compound 3

5

**156**  
-continued

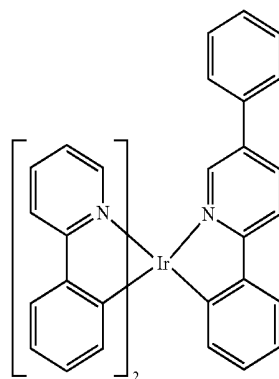

Compound 7

10

15

Compound 4

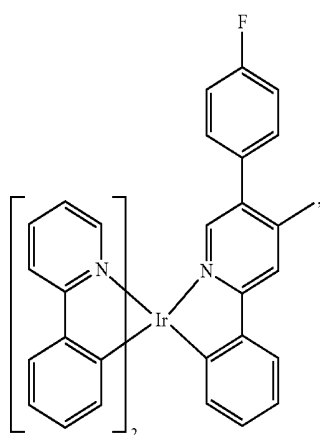

Compound 8

20

25

30

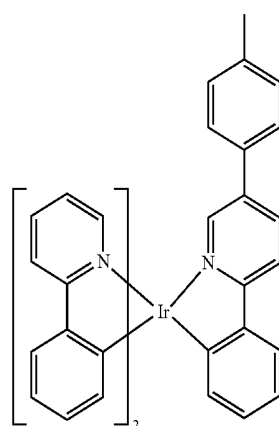

Compound 5

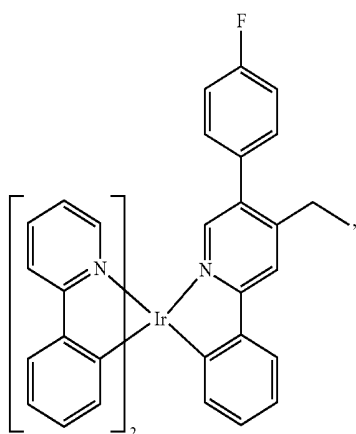

Compound 9

35

40

45

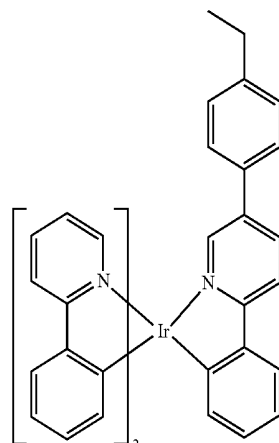

Compound 6

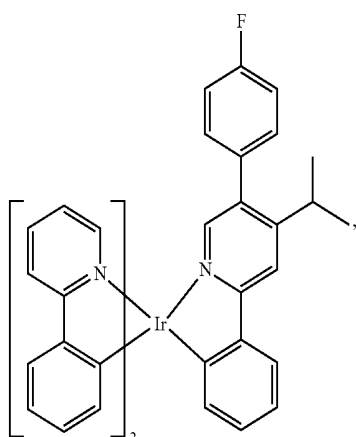

Compound 10

55

60

65

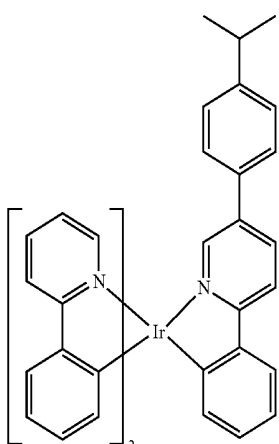

**157**  
-continued

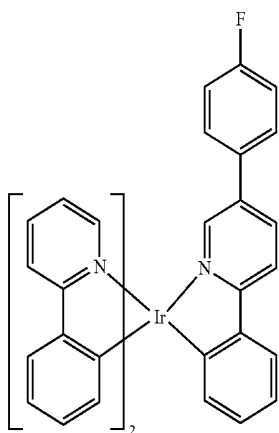

Compound 11

**158**  
-continued

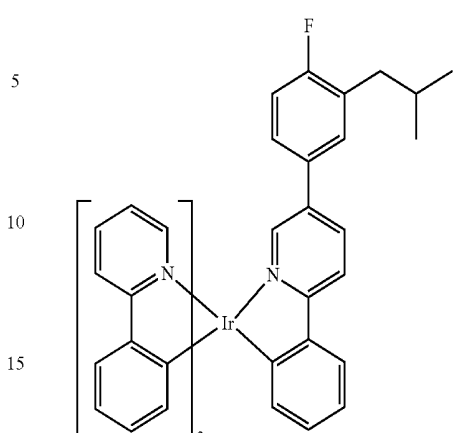

Compound 15

5

10

15

Compound 12

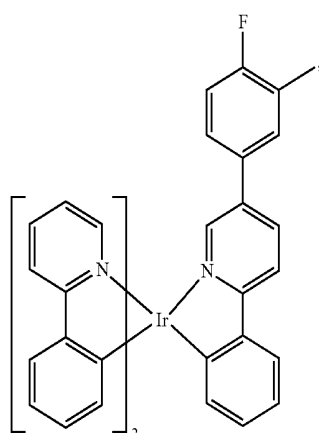

Compound 16

20

25

30

Compound 13

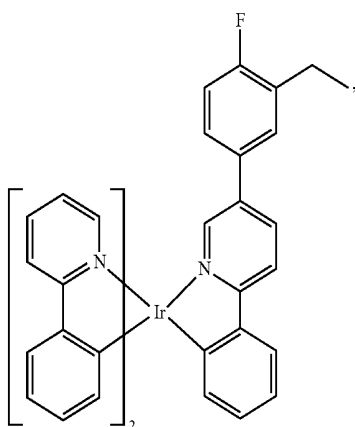

Compound 17

35

40

45

Compound 14

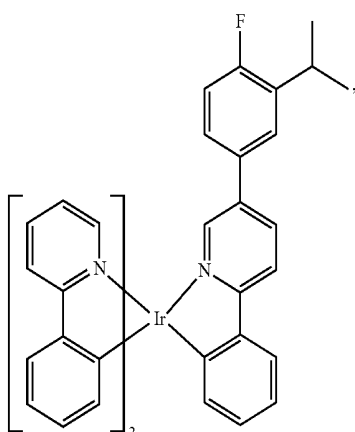

Compound 18

50

55

60

65

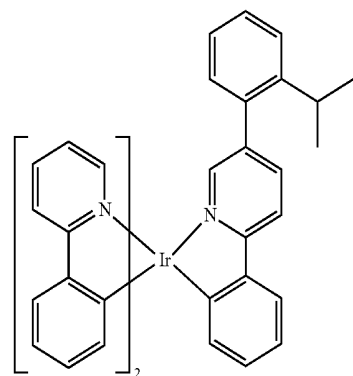
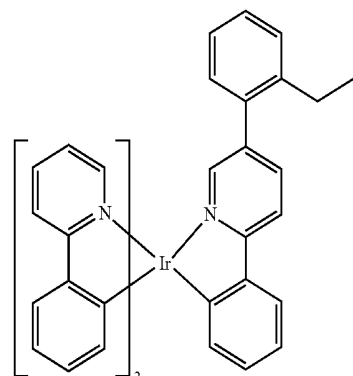
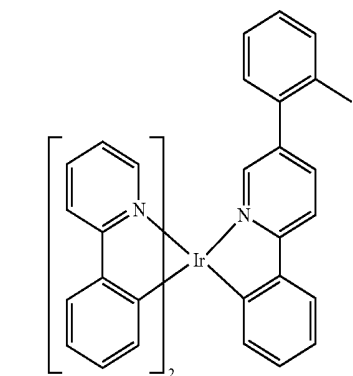

**159**  
-continued

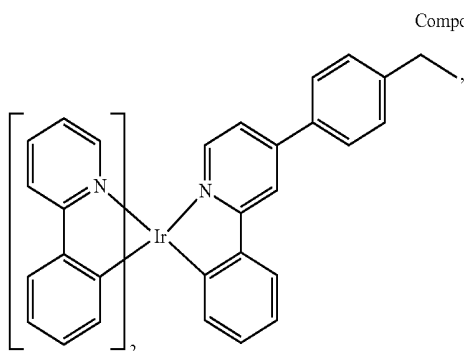
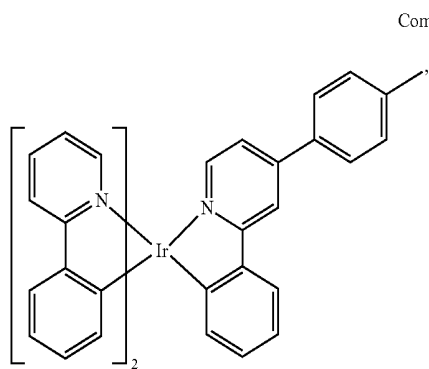
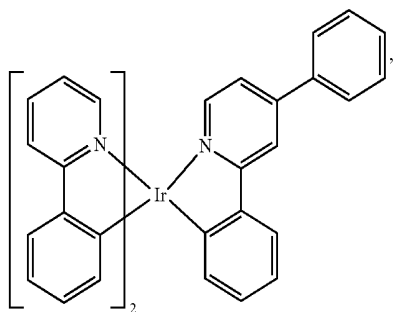
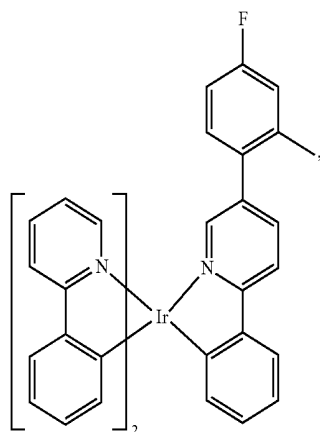

**160**  
-continued

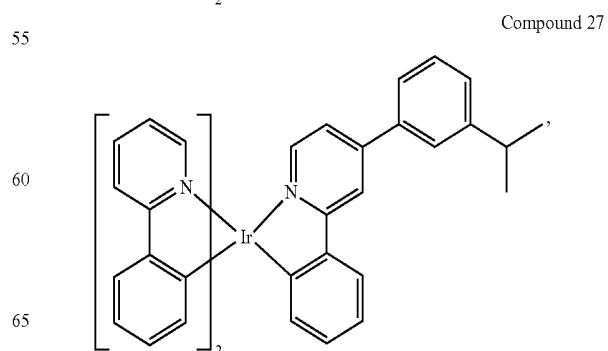
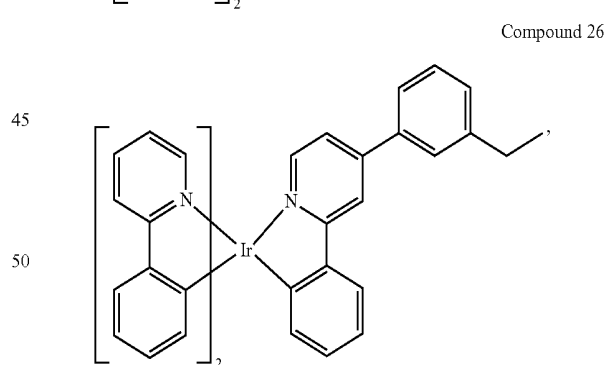
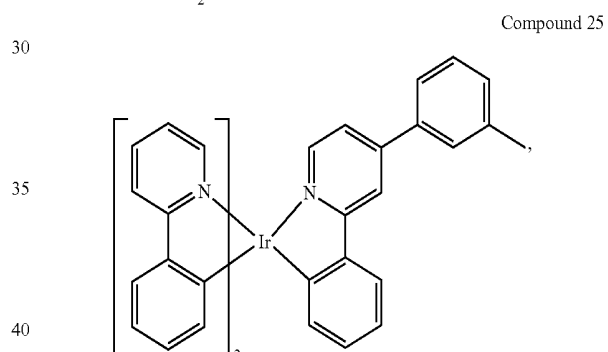
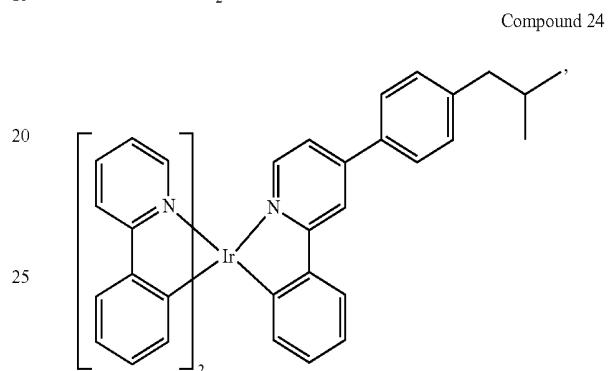
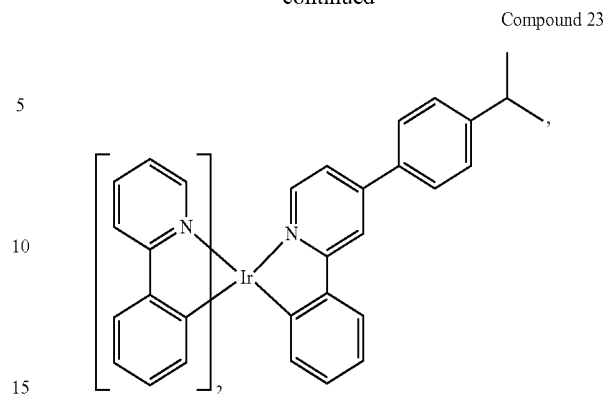

**161**  
-continued

Compound 28

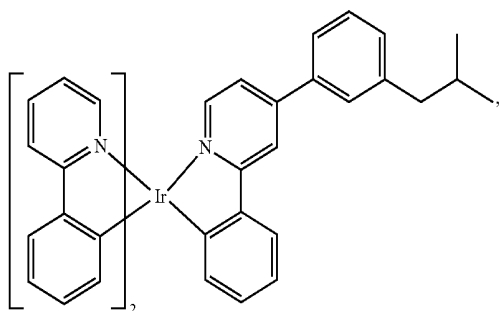

5

10

Compound 29 15

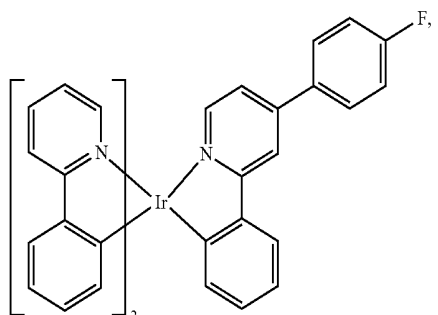

20

25

Compound 30

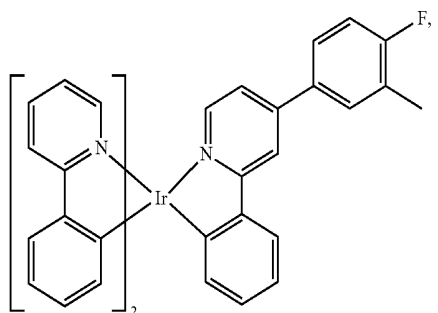

30

35

Compound 31

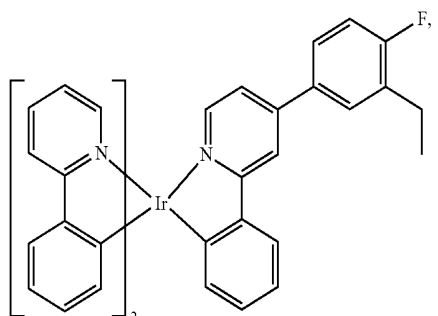

45

50

Compound 32

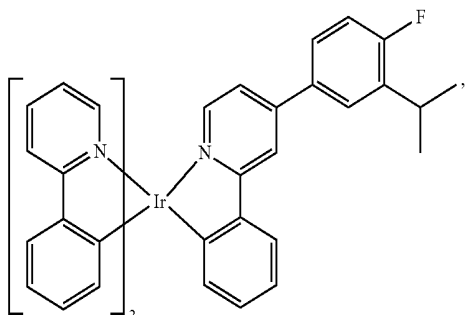

55

60

65

**162**

-continued

Compound 33

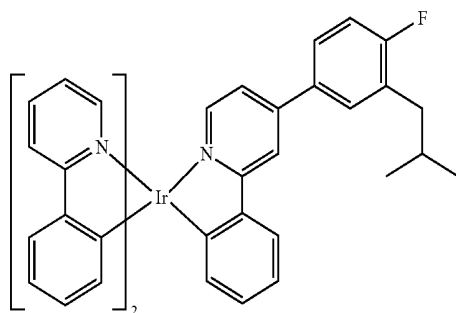

Compound 34

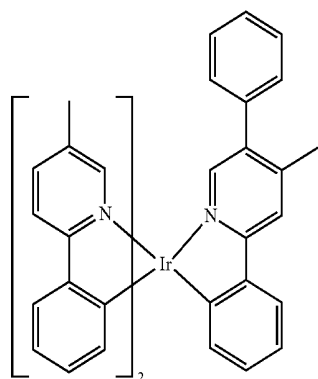

Compound 35

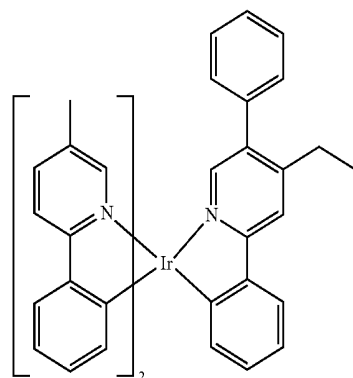

Compound 36

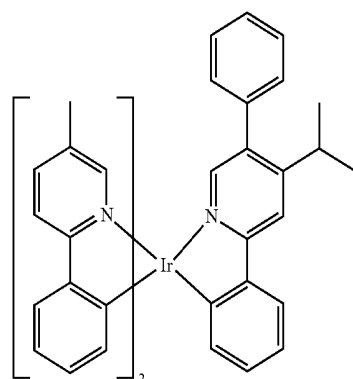

**163**  
-continued

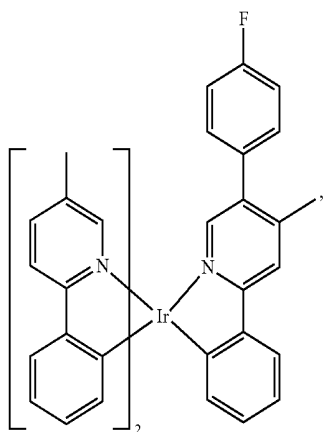

Compound 37

5

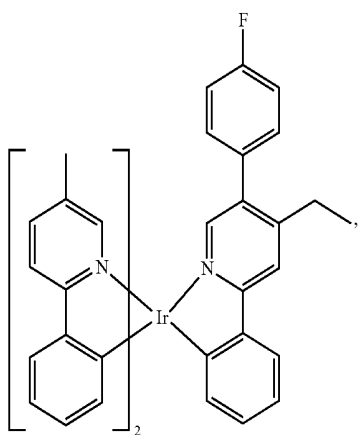

Compound 38

20

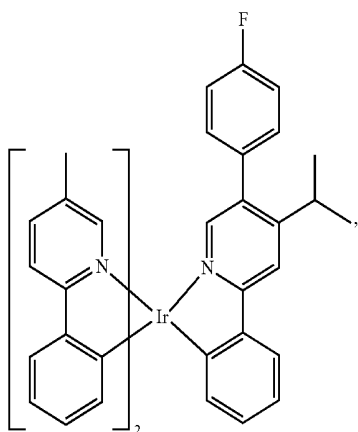

Compound 39

35

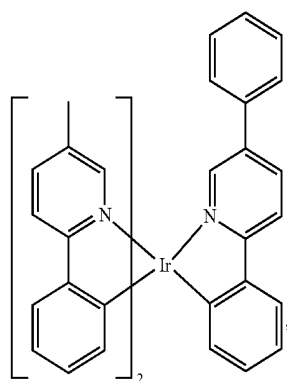

Compound 40

50

**164**  
-continued

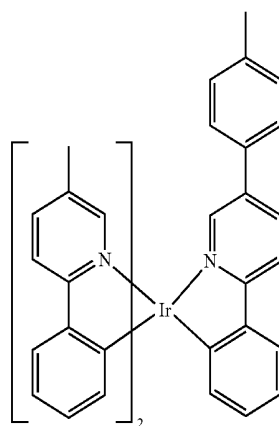

Compound 41

10

15

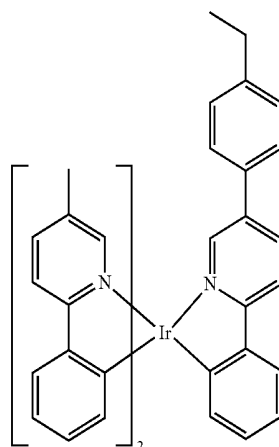

Compound 42

25

30

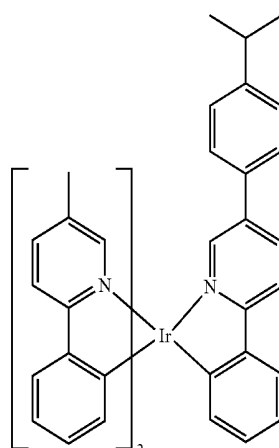

Compound 43

40

45

55

60

65

**165**  
-continued

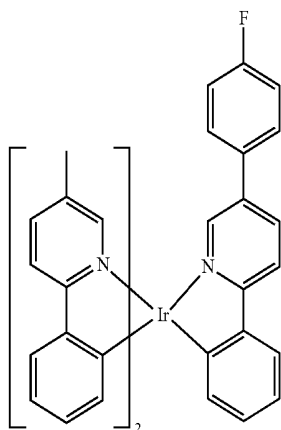

Compound 44

**166**  
-continued

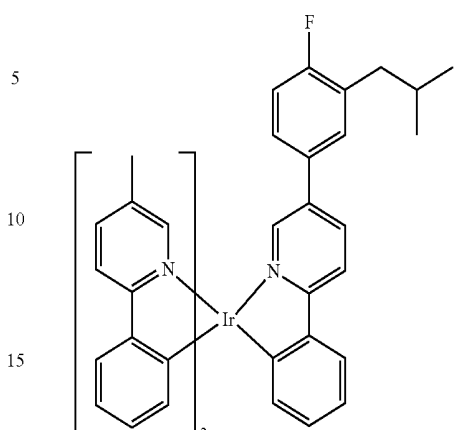

Compound 48

5

10

15

Compound 45

20

25

30

Compound 49

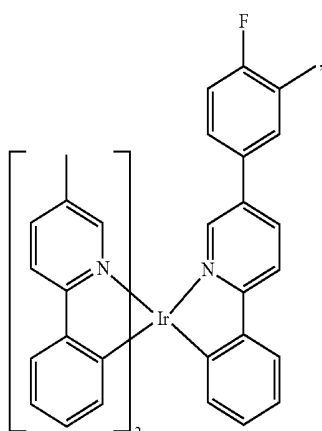

Compound 46

35

40

45

50

Compound 50

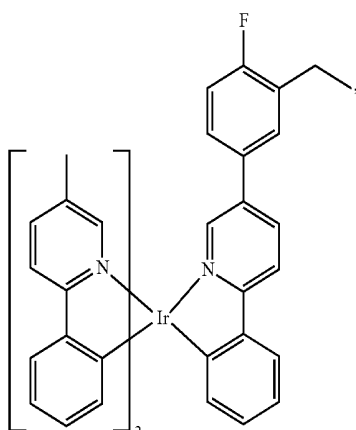

Compound 47

55

60

65

Compound 51

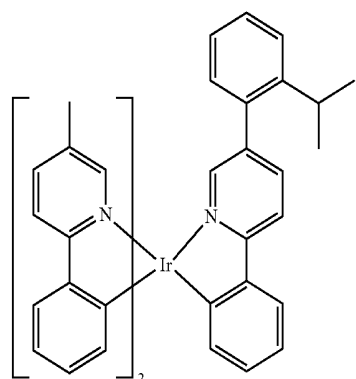
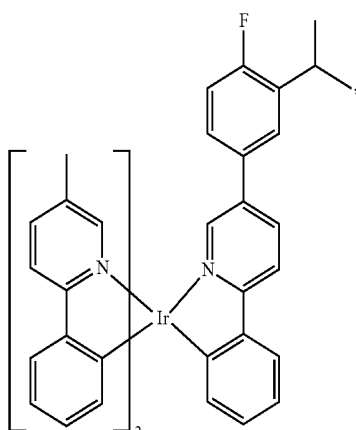

**167**  
-continued

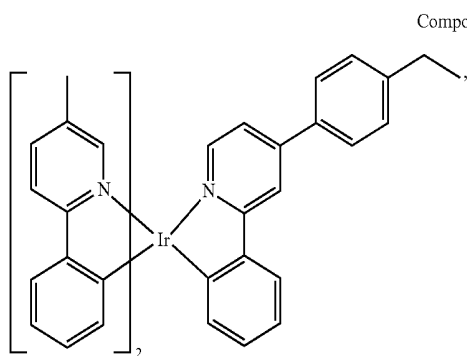
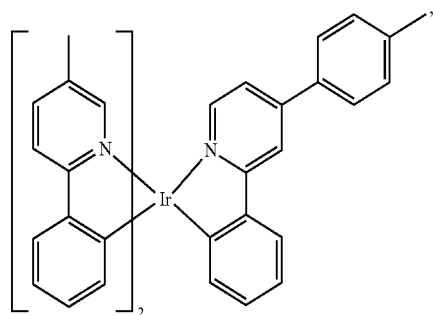
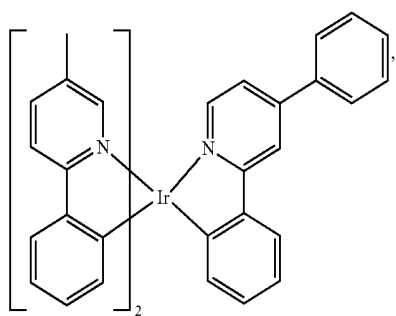
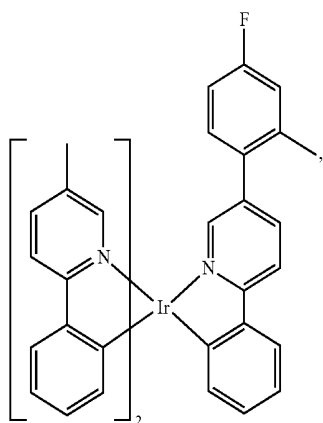

**168**  
-continued

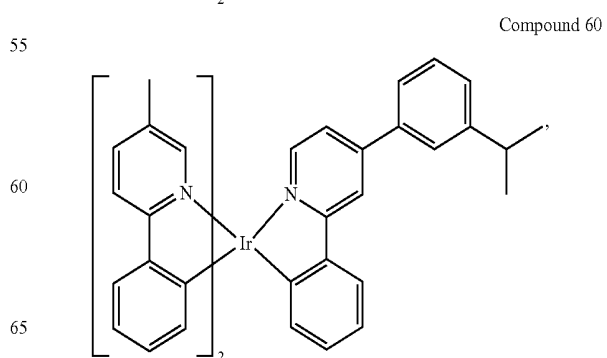
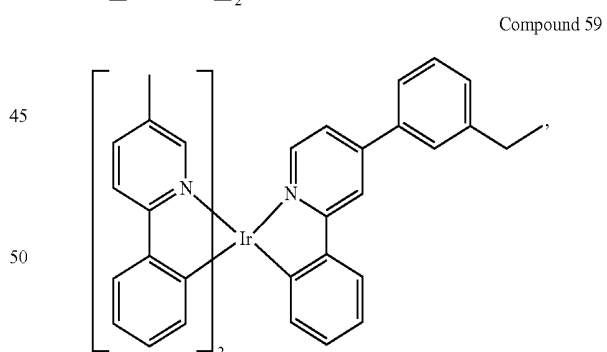
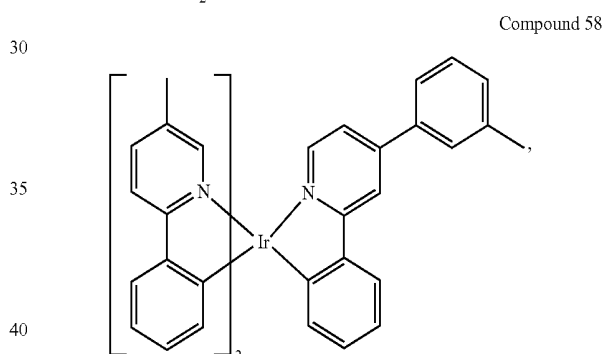
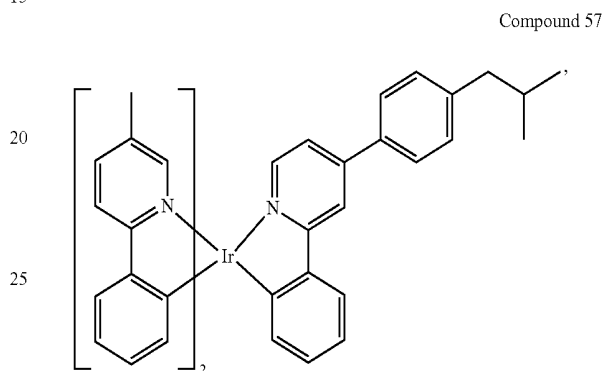
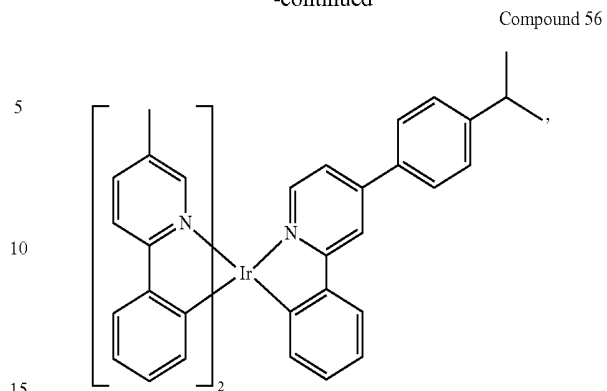

**169**  
-continued

**170**  
-continued

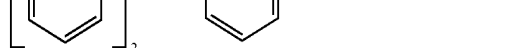
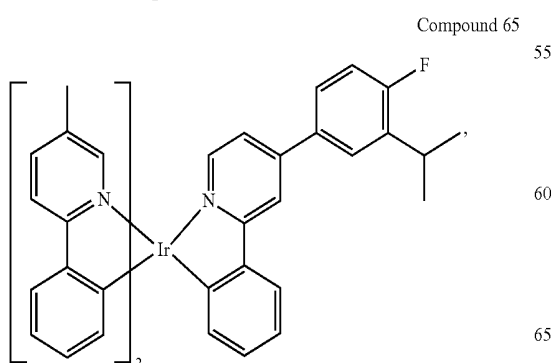
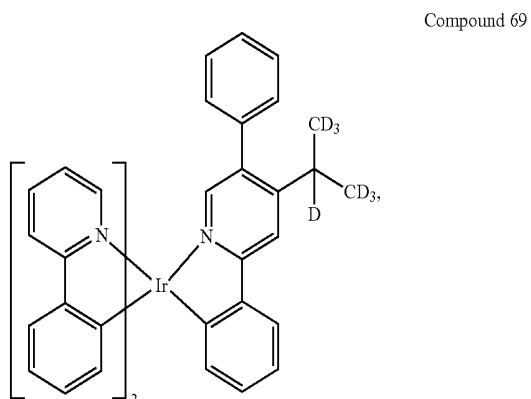
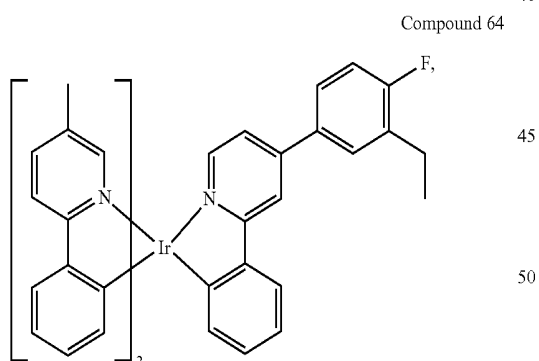
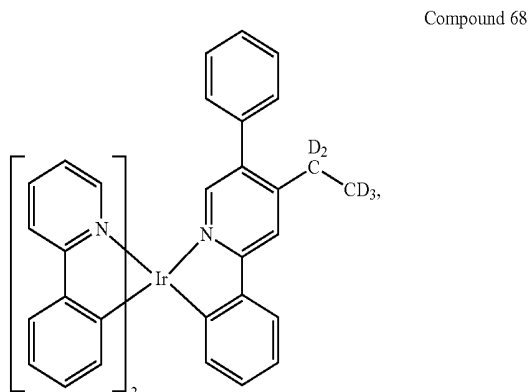
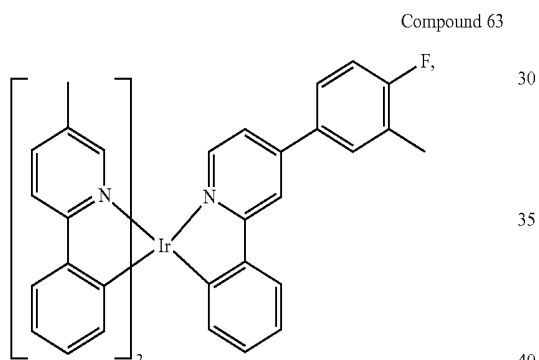
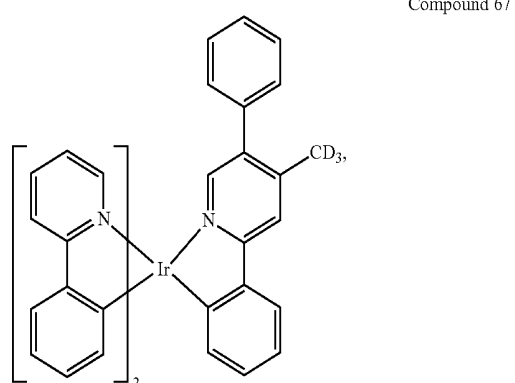
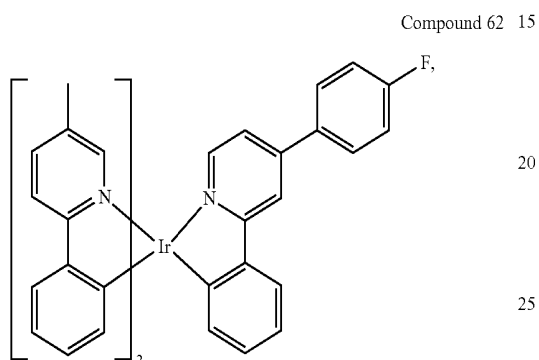
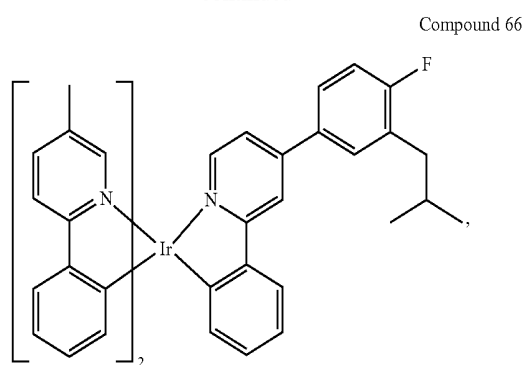
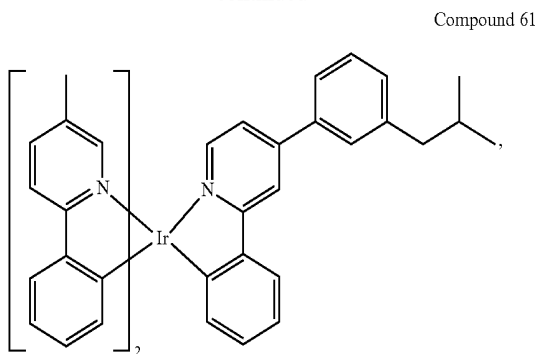

**171**  
-continued

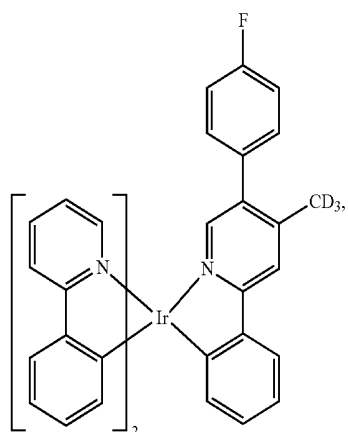

Compound 70

5

10

15

Compound 71

20

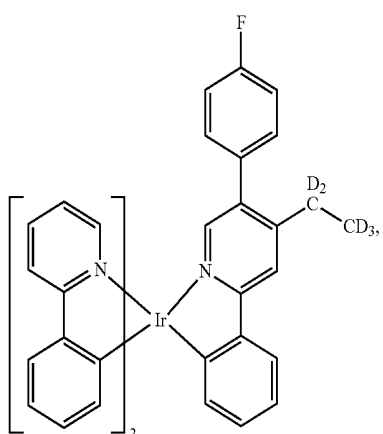

25

Compound 72

35

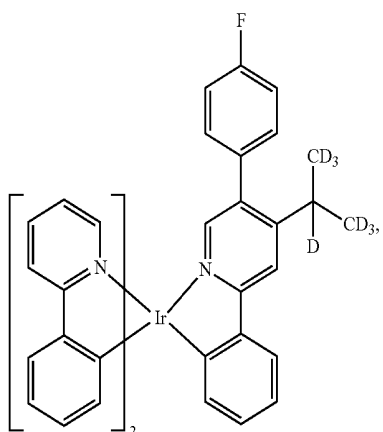

40

45

Compound 73

50

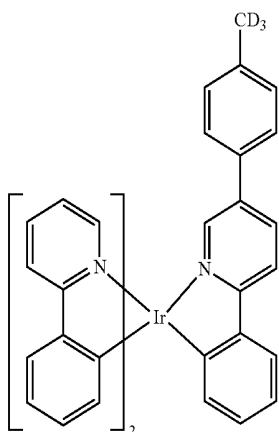

55

60

65

**172**  
-continued

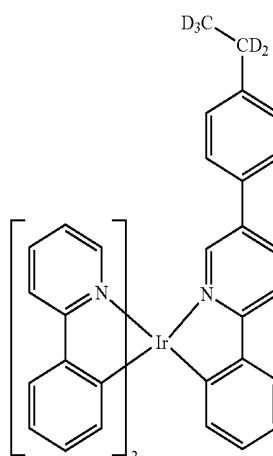

Compound 74

5

10

15

20

25

30

35

40

45

50

55

60

65

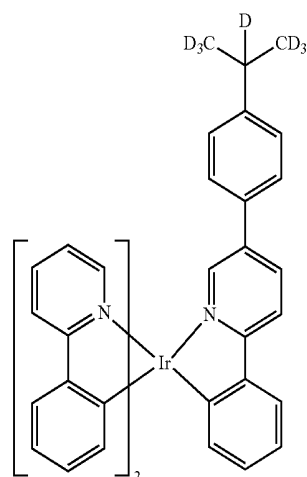

Compound 75

Compound 76

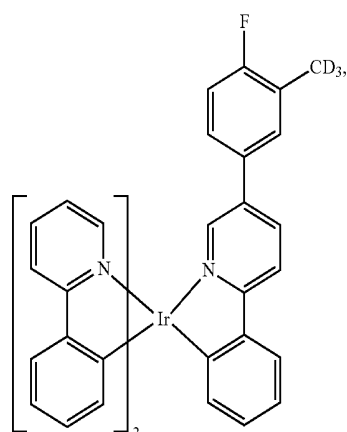

**173**  
-continued

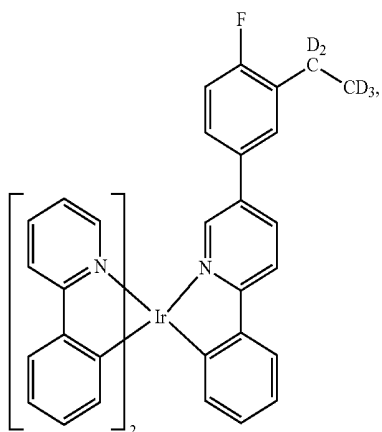

Compound 77

**174**  
-continued

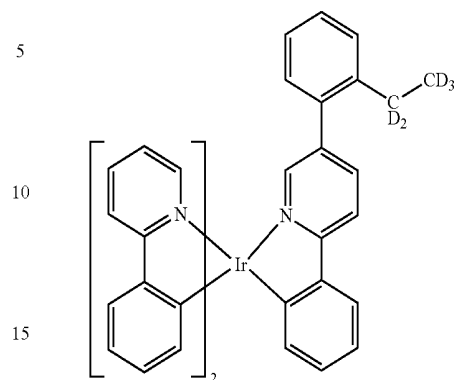

Compound 81

Compound 78

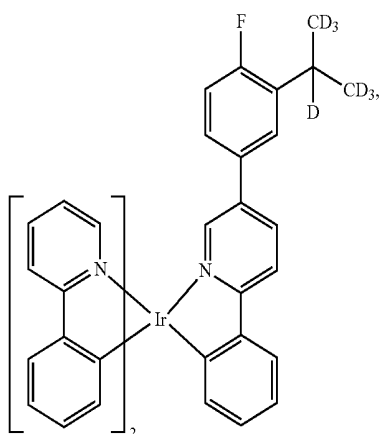

Compound 82

Compound 79

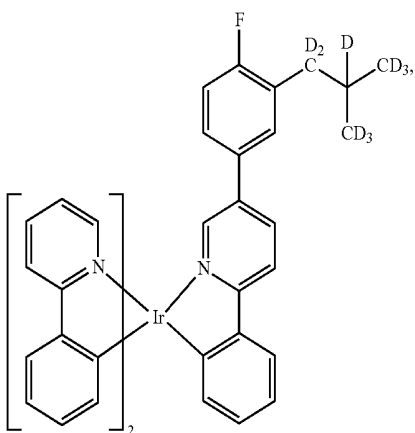

Compound 83

Compound 80

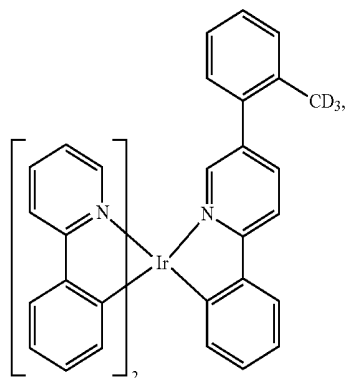

Compound 84

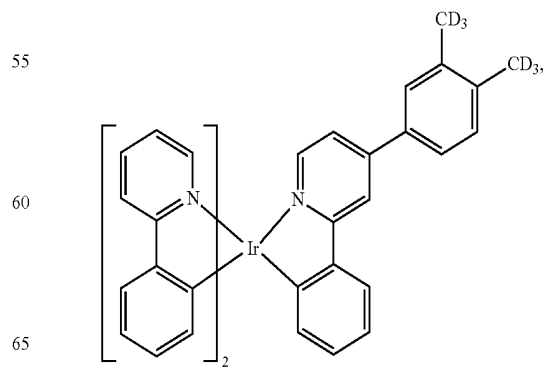

**175**  
-continued

Compound 85

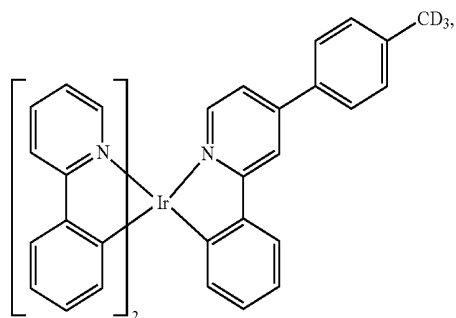

5

10

15

**176**  
-continued

Compound 89

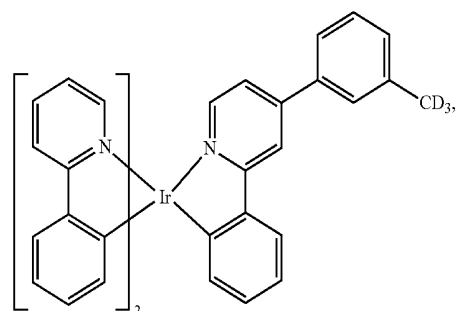

20

25

30

35

40

45

50

55

60

65

Compound 86

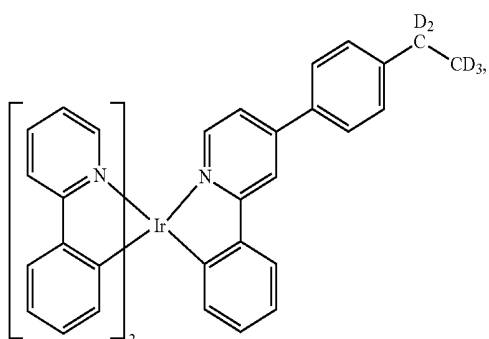

20

25

30

35

40

45

50

55

60

65

Compound 87

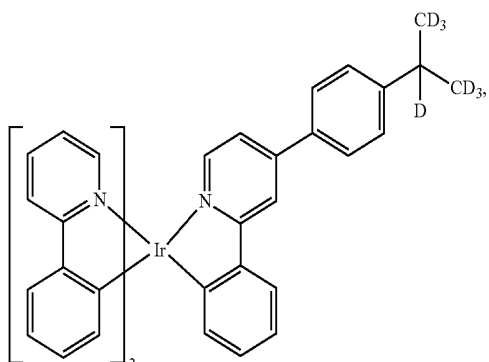

35

40

45

50

55

60

65

Compound 88

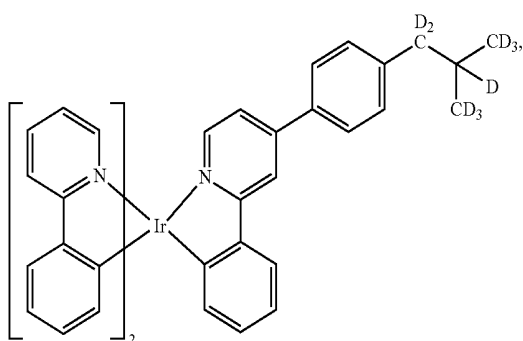

55

60

65

Compound 90

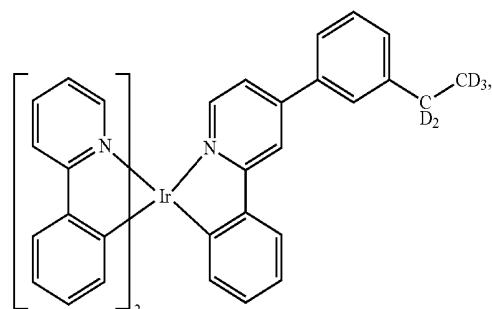

20

25

30

35

40

45

50

55

60

65

Compound 91

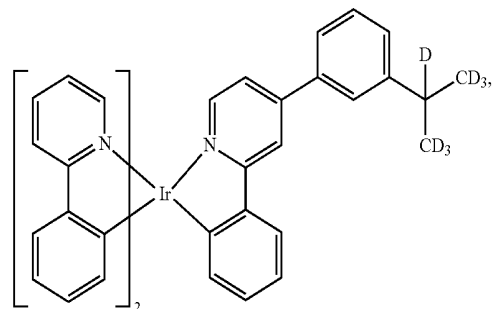

30

35

40

45

50

55

60

65

Compound 92

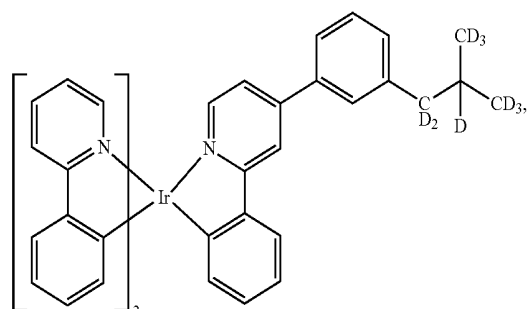

45

50

55

60

65

Compound 93

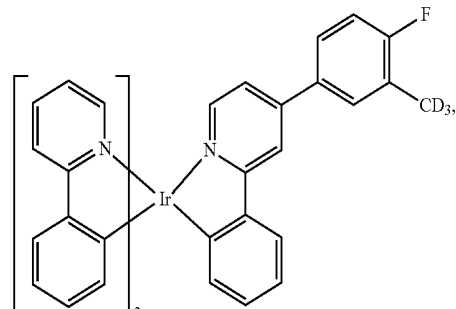

60

65

177  
-continued

178  
-continued

Compound 94

Compound 98

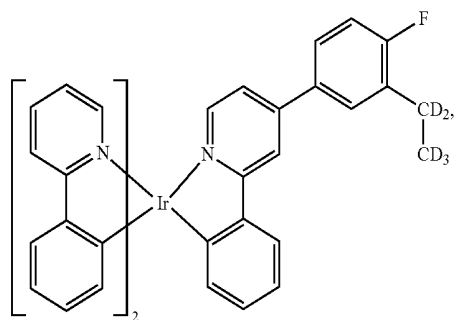

10

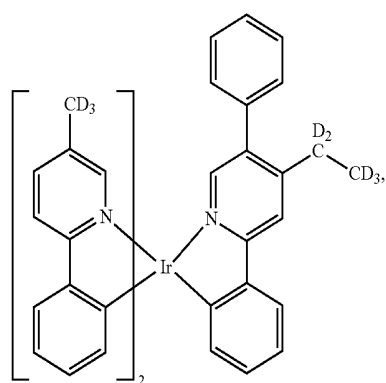

15

Compound 99

Compound 95

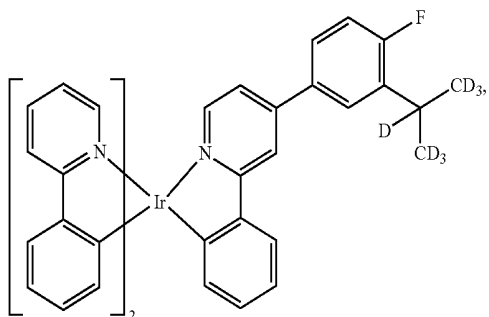

25

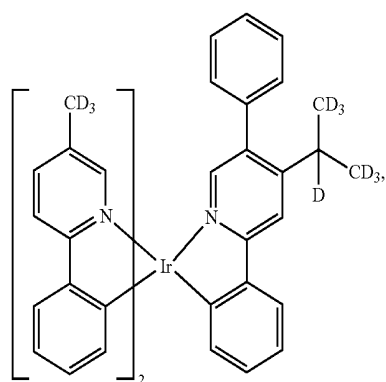

Compound 100

Compound 96

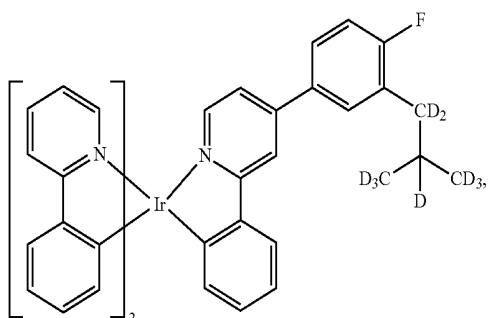

40

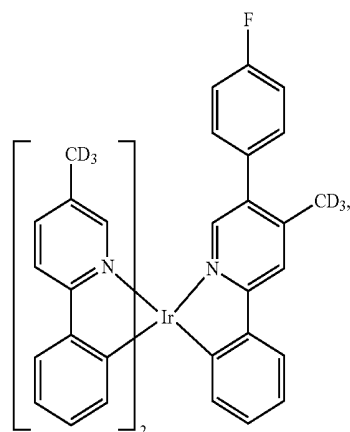

50

Compound 101

Compound 97

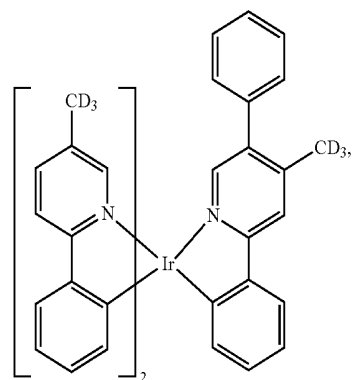

60

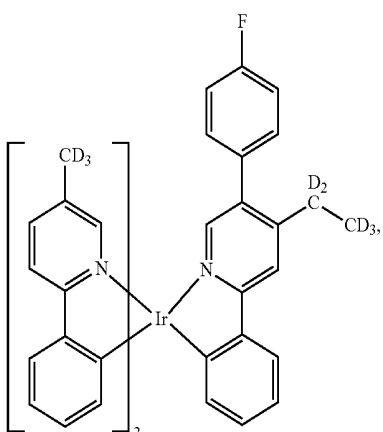

**179**  
-continued

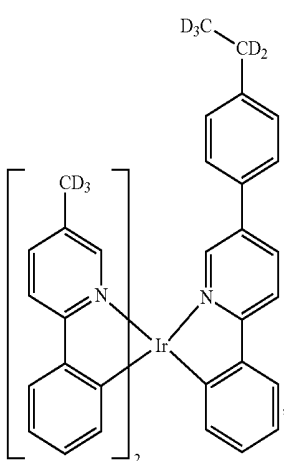
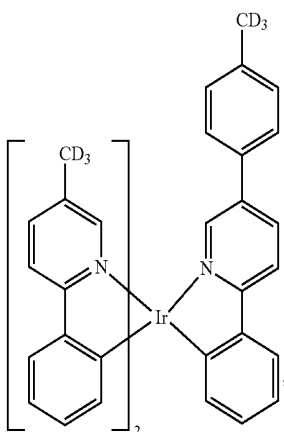
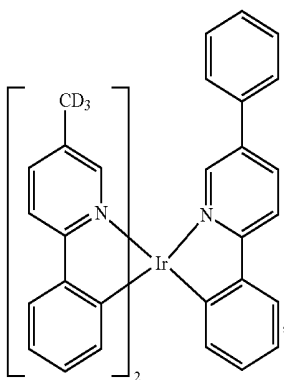
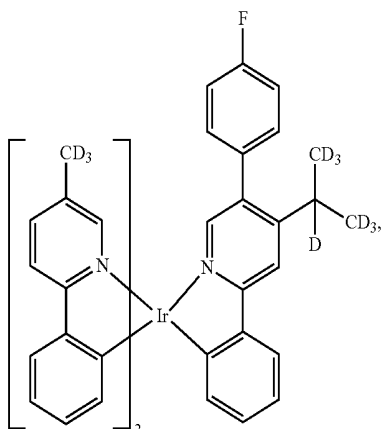

**180**  
-continued

Compound 102

5

10

15

Compound 103

20

25

Compound 104

35

40

45

Compound 105

50

55

60

65

Compound 106

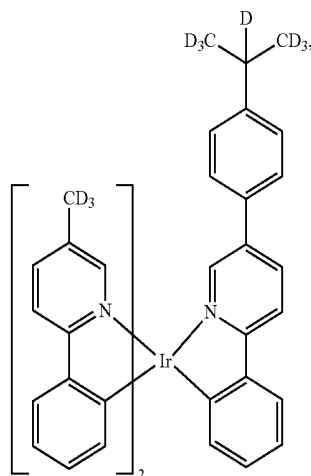

Compound 107

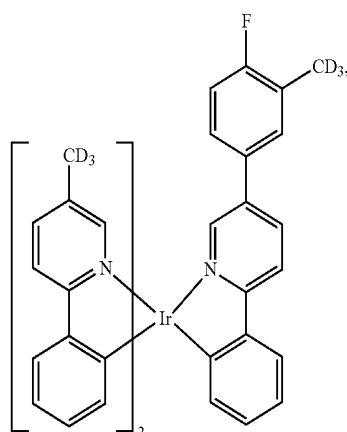

Compound 108

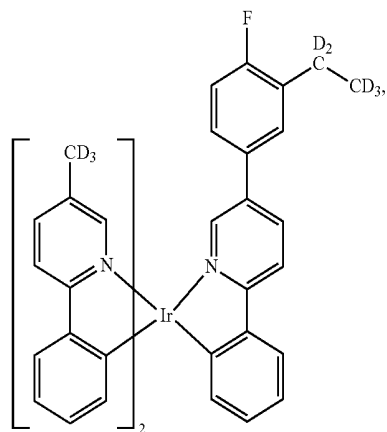

**181**  
-continued

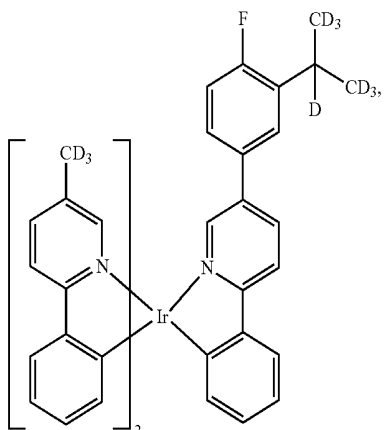

Compound 109

**182**  
-continued

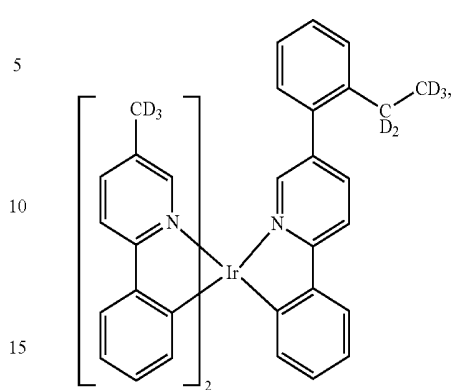

Compound 113

Compound 110

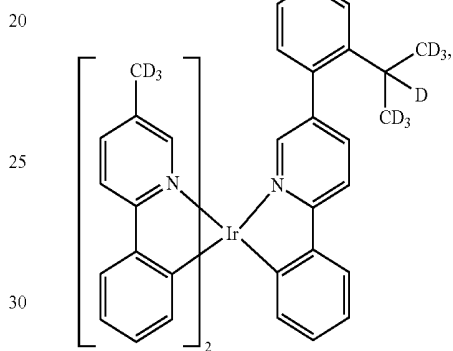
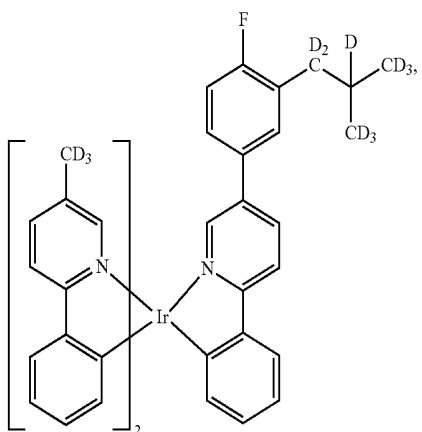

Compound 114

Compound 111

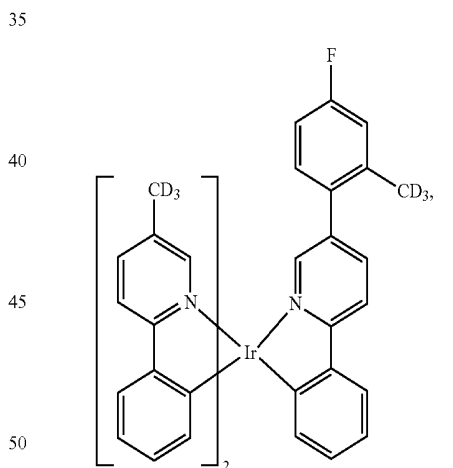
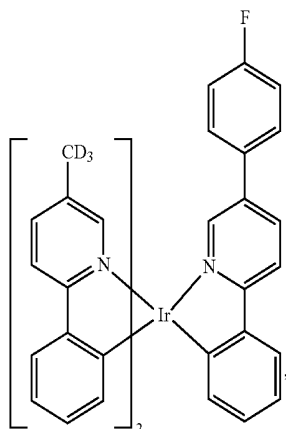

Compound 115

Compound 112

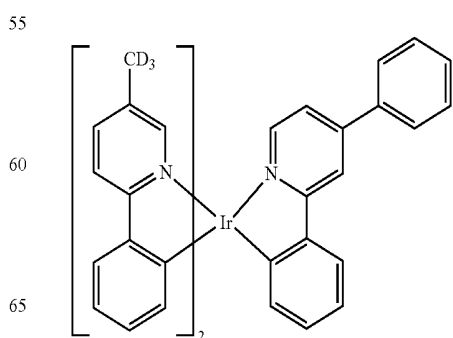
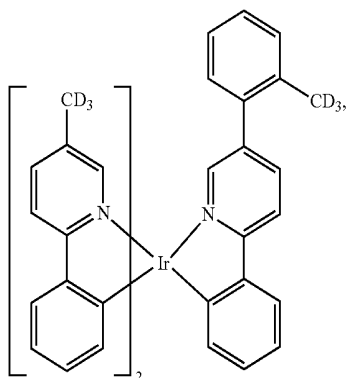

Compound 116

**183**  
-continued

**184**  
-continued

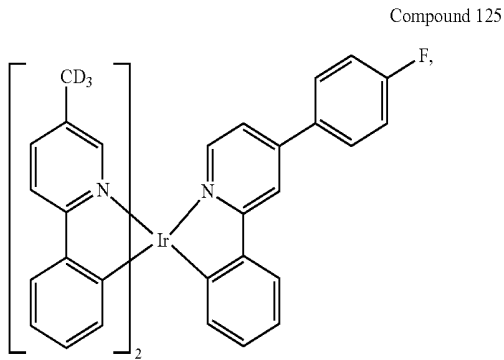
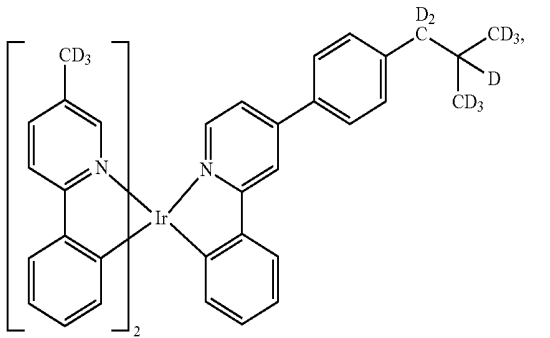
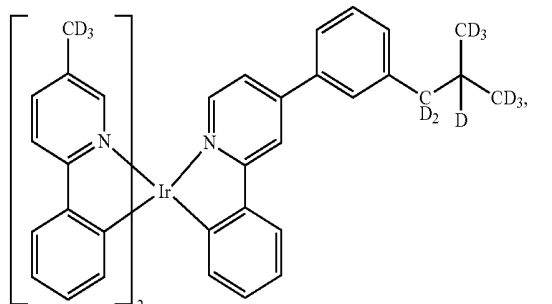
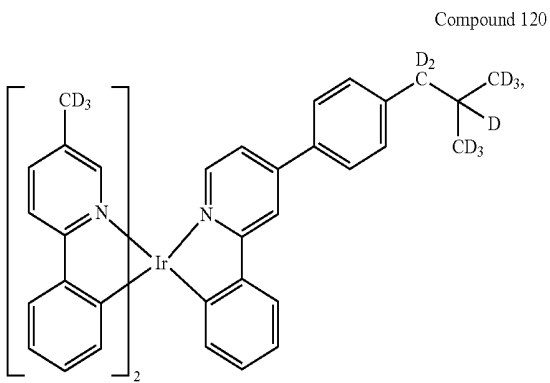
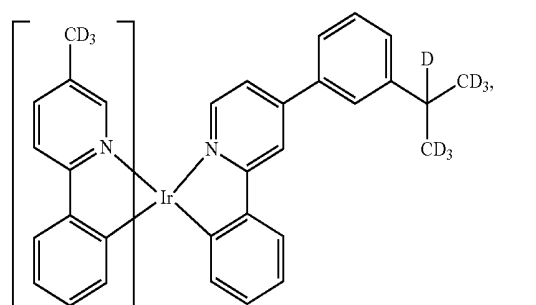
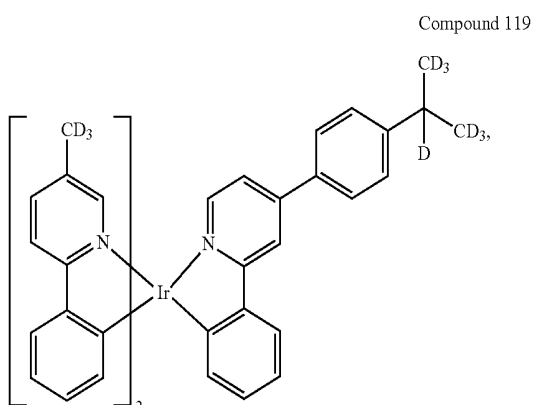
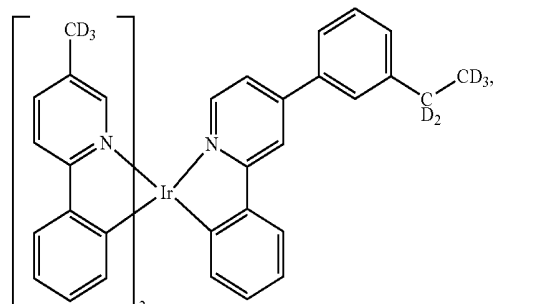
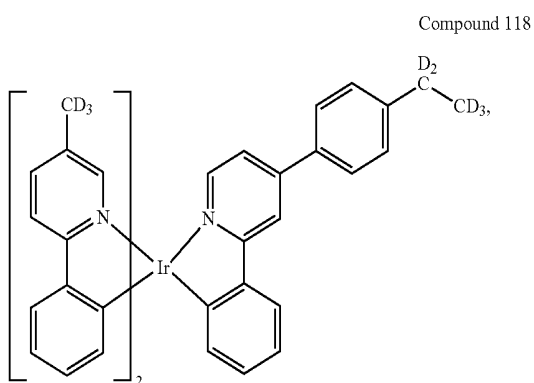
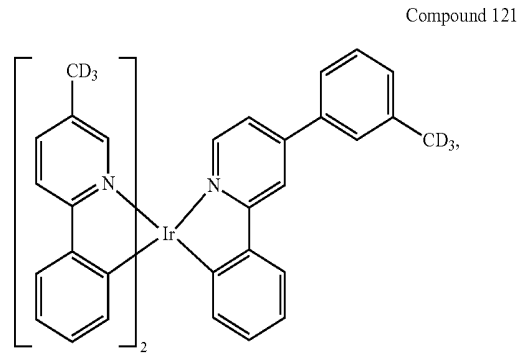
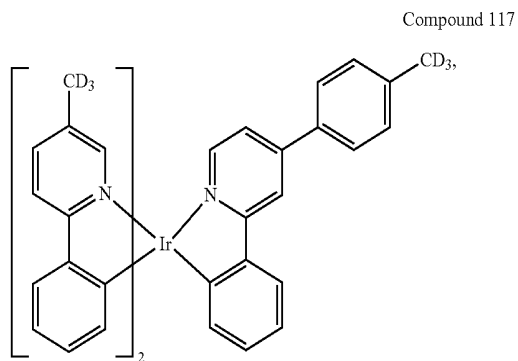

185

-continued

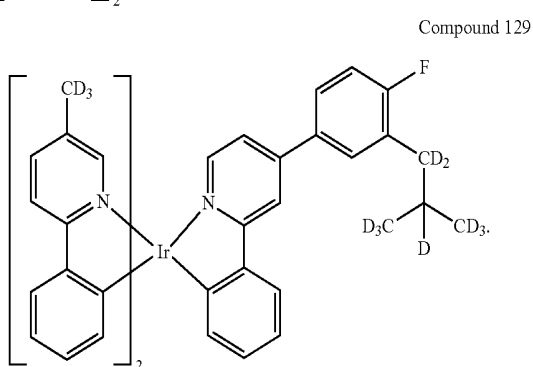
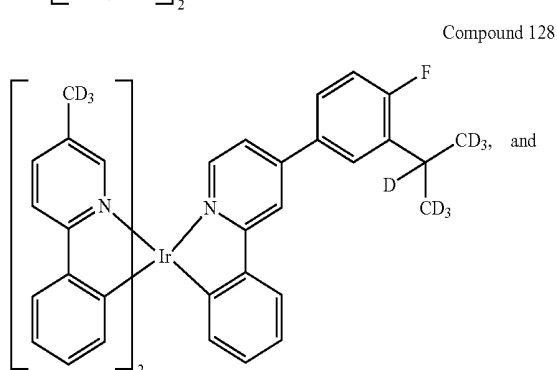
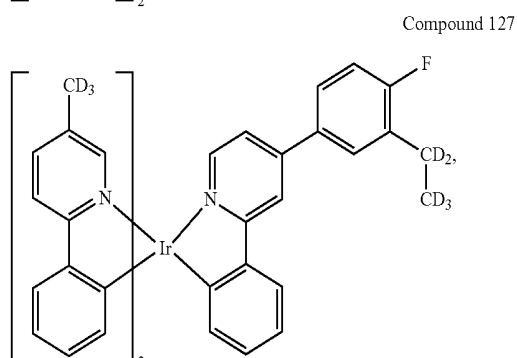
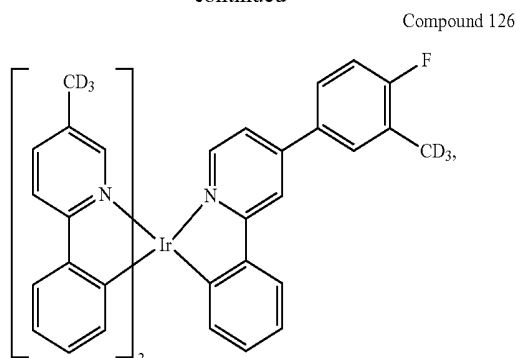

In one embodiment of the composition wherein the first compound has the structure according to Formula V and the second compound has the structure according to Formula VI defined above, the mixture of the first compound and the second compound is selected from the group consisting of: (Compound EH1 and Compound 4), (Compound EH2 and Compound 7), (Compound EH4 and Compound 3), (Compound EH5 and Compound 11), (Compound EH8 and Compound 1), (Compound EH8 and Compound 67), (Compound EH16 and Compound 21), (Compound EH28 and Compound 29), (Compound EH40 and Compound 34), and (Compound EH40 and Compound 97).

186

In another embodiment of the composition wherein the first compound has the structure according to Formula V and the second compound has the structure according to Formula VI defined above, the mixture of the first compound and the second compound is (Compound EH40 and Compound 97).

According to another aspect of the present disclosure, a first device comprising a first OLED is disclosed. The first OLED comprising: an anode; a cathode; and an organic layer disposed between the anode and the cathode, comprising a first composition comprising a mixture of a first compound and a second compound, wherein the first compound has different chemical structure than the second compound;

wherein the first compound is capable of functioning as a phosphorescent emitter in an organic light emitting device at room temperature;

wherein the first compound has an evaporation temperature T1 of 150 to 350° C.;

wherein the second compound has an evaporation temperature T2 of 150 to 350° C.;

wherein the absolute value of T1-T2 is less than 20° C.;

wherein the first compound has a concentration C1 in said mixture, and a concentration C2 in a film formed by evaporating the mixture in a vacuum deposition tool at a constant pressure between  $1 \times 10^{-6}$  Torr to  $1 \times 10^{-9}$  Torr, at a 2 Å/sec deposition rate on a surface positioned at a predefined distance away from the material; and

wherein the absolute value of  $(C1-C2)/C1$  is less than 5%.

Preferably the absolute value of  $(C1-C2)/C1$  is less than 3%.

In one embodiment of the first device, the organic layer is an emissive layer. In another embodiment of the first device, the organic layer is a non-emissive layer.

In one embodiment of the first device, the organic layer further comprises a phosphorescent emitting material.

In one embodiment of the first device, the organic layer further comprises a host.

In one embodiment of the first device, the first compound functions as a phosphorescent emitting material.

In one embodiment of the first device, the first compound functions as a host.

In one embodiment of the first device, the first device further comprises a second organic light emitting device separate from the first organic light emitting device, and wherein the second organic light emitting device comprises an emitting dopant having a peak wavelength of between 400 to 500 nanometers.

In one embodiment of the first device, the first organic light emitting device comprises a first emissive layer and a second emissive layer; wherein the first emissive layer comprises the first composition; and the second emissive layer comprises an emitting dopant having a peak wavelength of between 400 to 500 nanometers.

In one embodiment of the first device, the first device is a consumer product. In another embodiment, the first device is an organic light-emitting device. In another embodiment, the first device is a lighting panel.

In one embodiment of the first device, the first composition leaves a residue corresponding to less than 5 wt % of the original charge in the sublimation crucible after the depletion of the first composition in the evaporation process. Preferably, the first composition is deposited in a vacuum system having a pressure level in the range of  $1 \times 10^{-8}$  Torr to  $1 \times 10^{-12}$  Torr.

According to another aspect of the present disclosure, a method for fabricating an organic light emitting device comprising a first electrode, a second electrode, and a first

187

organic layer disposed between the first electrode and the second electrode, wherein the first organic layer comprises a first composition comprising a mixture of a first compound and a second compound is disclosed. The method comprises the following: providing a substrate having the first electrode disposed thereon; depositing the first composition over the first electrode; and depositing the second electrode over the first organic layer,

wherein the first compound has different chemical structure than the second compound,

wherein the first compound is capable of functioning as a phosphorescent emitter in an organic light emitting device at room temperature,

wherein the first compound has an evaporation temperature T1 of 150 to 350° C.,

wherein the second compound has an evaporation temperature T2 of 150 to 350° C.,

wherein the absolute value of T1-T2 is less than 20° C.,

wherein the first compound has a concentration C1 in said mixture, and a concentration C2 in a film formed by evaporating the mixture in a vacuum deposition tool at a constant pressure between  $1 \times 10^{-6}$  Torr to  $1 \times 10^{-9}$  Torr, at a 2 Å/sec deposition rate on a surface positioned at a predefined distance away from the material, and wherein the absolute value of  $(C1-C2)/C1$  is less than 5%.

#### Combination with Other Materials

The materials described herein as useful for a particular layer in an organic light emitting device may be used in combination with a wide variety of other materials present in the device. For example, emissive dopants disclosed herein may be used in conjunction with a wide variety of hosts, transport layers, blocking layers, injection layers, electrodes and other layers that may be present. The materials described or referred to below are non-limiting examples of materials that may be useful in combination with the compounds disclosed herein, and one of skill in the art can readily consult the literature to identify other materials that may be useful in combination.

#### HIL/HTL:

A hole injecting/transporting material to be used in the present invention is not particularly limited, and any compound may be used as long as the compound is typically used as a hole injecting/transporting material. Examples of the material include, but not limit to: a phthalocyanine or porphyrin derivative; an aromatic amine derivative; an indolocarbazole derivative; a polymer containing fluorohydrocarbon; a polymer with conductivity dopants; a conducting polymer, such as PEDOT/PSS; a self-assembly monomer derived from compounds such as phosphoric acid and silane derivatives; a metal oxide derivative, such as  $\text{MoO}_x$ ; a p-type semiconducting organic compound, such as 1,4,5,8,9,12-Hexaazatriphenylenehexacarbonitrile; a metal complex, and a cross-linkable compounds.

Examples of aromatic amine derivatives used in HIL or HTL include, but not limit to the following general structures:

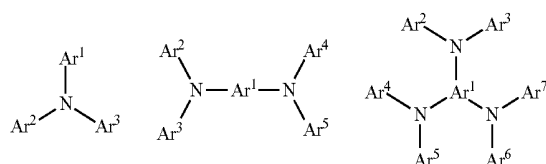

188

-continued

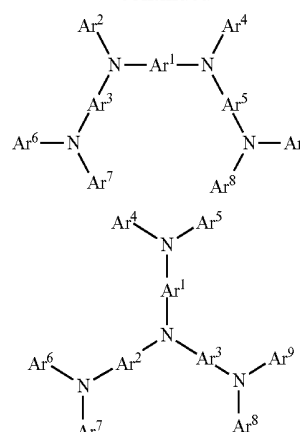

Each of Ar<sup>1</sup> to Ar<sup>9</sup> is selected from the group consisting of aromatic hydrocarbon cyclic compounds such as benzene, biphenyl, biphenyl, triphenylene, naphthalene, anthracene, phenalene, phenanthrene, fluorene, pyrene, chrysene, perylene, azulene; group consisting of aromatic heterocyclic compounds such as dibenzothiophene, dibenzofuran, dibenzoselenophene, thiophene, benzofuran, benzothiophene, benzoselenophene, carbazole, indolocarbazole, pyridylindole, pyrrolodipyridine, pyrazole, imidazole, triazole, oxazole, thiazole, oxadiazole, oxatriazole, dioxazole, thiazole, pyridine, pyridazine, pyrimidine, pyrazine, triazine, oxazine, oxathiazine, oxadiazine, indole, benzimidazole, indazole, indoxazine, benzoxazole, benzisoxazole, benzothiazole, quinoline, isoquinoline, cinnoline, quinazoline, quinoxaline, naphthyridine, phthalazine, pteridine, xanthene, acridine, phenazine, phenothiazine, phenoxazine, benzofuropyridine, furodipyridine, benzothienopyridine, thienodipyridine, benzoselenophenopyridine, and selenophenodipyridine; and group consisting of 2 to 10 cyclic structural units which are groups of the same type or different types selected from the aromatic hydrocarbon cyclic group and the aromatic heterocyclic group and are bonded to each other directly or via at least one of oxygen atom, nitrogen atom, sulfur atom, silicon atom, phosphorus atom, boron atom, chain structural unit and the aliphatic cyclic group. Wherein each Ar is further substituted by a substituent selected from the group consisting of hydrogen, deuterium, halide, alkyl, cycloalkyl, heteroalkyl, arylalkyl, alkoxy, aryloxy, amino, silyl, alkenyl, cycloalkenyl, heteroalkenyl, alkynyl, aryl, heteroaryl, acyl, carbonyl, carboxylic acids, ester, nitrile, isonitrile, sulfanyl, sulfinyl, sulfonyl, phosphino, and combinations thereof.

In one aspect, Ar<sup>1</sup> to Ar<sup>9</sup> is independently selected from the group consisting of:

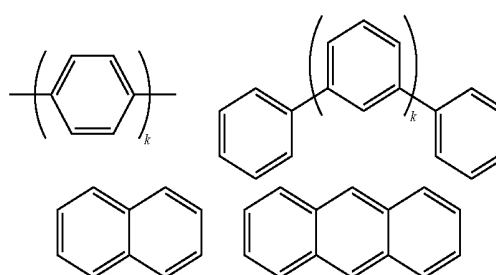

189

-continued

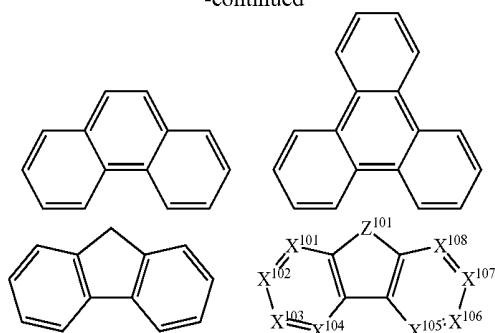

wherein k is an integer from 1 to 20; X<sup>101</sup> to X<sup>108</sup> is C (including CH) or N; Z<sup>101</sup> is NAr<sup>1</sup>, O, or S; Ar<sup>1</sup> has the same group defined above.

Examples of metal complexes used in HIL or HTL include, but not limit to the following general formula:

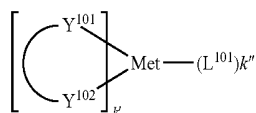

wherein Met is a metal, which can have an atomic weight greater than 40; (Y<sup>101</sup>-Y<sup>102</sup>) is a bidentate ligand, Y<sup>101</sup> and Y<sup>102</sup> are independently selected from C, N, O, P, and S; L<sup>101</sup> is an ancillary ligand; k' is an integer value from 1 to the maximum number of ligands that may be attached to the metal; and k'+k'' is the maximum number of ligands that may be attached to the metal.

In one aspect, (Y<sup>101</sup>-Y<sup>102</sup>) is a 2-phenylpyridine derivative. In another aspect, (Y<sup>101</sup>-Y<sup>102</sup>) is a carbene ligand. In another aspect, Met is selected from Ir, Pt, Os, and Zn. In a further aspect, the metal complex has a smallest oxidation potential in solution vs. Fe<sup>+</sup>/Fe couple less than about 0.6 V. Host:

The light emitting layer of the organic EL device of the present invention preferably contains at least a metal complex as light emitting material, and may contain a host material using the metal complex as a dopant material. Examples of the host material are not particularly limited, and any metal complexes or organic compounds may be used as long as the triplet energy of the host is larger than that of the dopant. While the Table below categorizes host materials as preferred for devices that emit various colors, any host material may be used with any dopant so long as the triplet criteria is satisfied.

Examples of metal complexes used as host are preferred to have the following general formula:

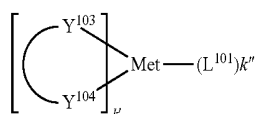

wherein Met is a metal; (Y<sup>103</sup>-Y<sup>104</sup>) is a bidentate ligand, Y<sup>103</sup> and Y<sup>104</sup> are independently selected from C, N, O, P, and S; L<sup>101</sup> is an another ligand; k' is an integer value from 1 to the maximum number of ligands that may be attached to the metal; and k'+k'' is the maximum number of ligands that may be attached to the metal.

190

In one aspect, the metal complexes are:

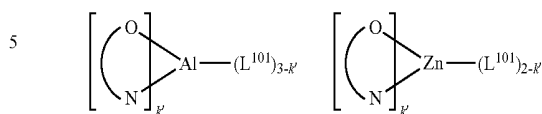

wherein (O—N) is a bidentate ligand, having metal coordinated to atoms O and N.

In another aspect, Met is selected from Ir and Pt. In a further aspect, (Y<sup>103</sup>-Y<sup>104</sup>) is a carbene ligand.

Examples of organic compounds used as host are selected from the group consisting aromatic hydrocarbon cyclic compounds such as benzene, biphenyl, triphenyl, triphenylene, naphthalene, anthracene, phenalene, phenanthrene, fluorene, pyrene, chrysene, perylene, azulene; group consisting aromatic heterocyclic compounds such as dibenzothiophene, dibenzofuran, dibenzoselenophene, furan, thiophene, benzofuran, benzothiophene, benzoselenophene, carbazole, indolocarbazole, pyridylindole, pyrrolodipyridine, pyrazole, imidazole, triazole, oxazole, thiazole, oxadiazole, oxatriazole, dioxazole, thiadiazole, pyridine, pyridazine, pyrimidine, pyrazine, triazine, oxazine, oxathiazine, oxadiazine, indole, benzimidazole, indazole, indoxazine, benzoxazole, benzisoxazole, benzothiazole, quinoline, isoquinoline, cinnoline, quinazoline, quinoxaline, naphthyridine, phthalazine, pteridine, xanthene, acridine, phenazine, phenothiazine, phenoxazine, benzofuropyridine, furodipyridine, benzothienopyridine, thienodipyridine, benzoselenophenopyridine, and selenophenodipyridine; and group consisting 2 to 10 cyclic structural units which are groups of the same type or different types selected from the aromatic hydrocarbon cyclic group and the aromatic heterocyclic group and are bonded to each other directly or via at least one of oxygen atom, nitrogen atom, sulfur atom, silicon atom, phosphorus atom, boron atom, chain structural unit and the aliphatic cyclic group. Wherein each group is further substituted by a substituent selected from the group consisting of hydrogen, deuterium, halide, alkyl, cycloalkyl, heteroalkyl, arylalkyl, alkoxy, aryloxy, amino, silyl, alkenyl, cycloalkenyl, heteroalkenyl, alkynyl, aryl, heteroaryl, acyl, carbonyl, carboxylic acids, ester, nitrile, isonitrile, sulfanyl, sulfinyl, sulfonyl, phosphino, and combinations thereof.

In one aspect, host compound contains at least one of the following groups in the molecule:

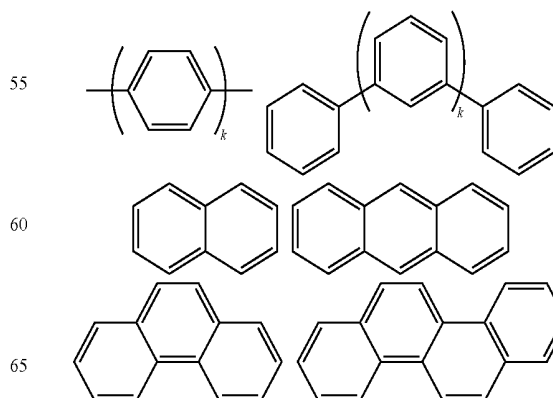

191

-continued

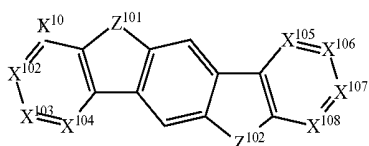
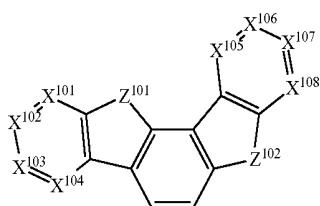
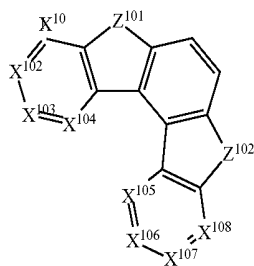
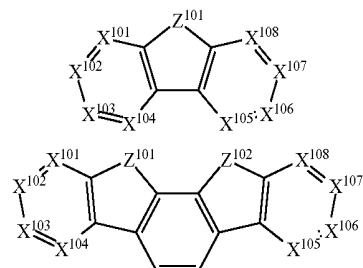
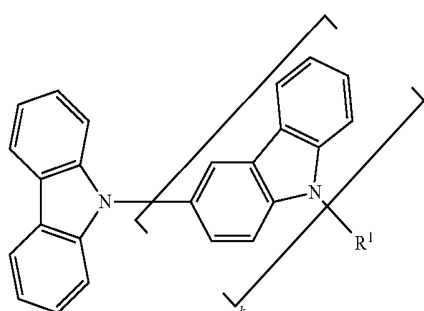
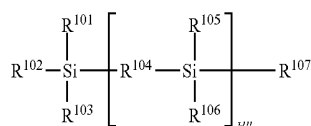
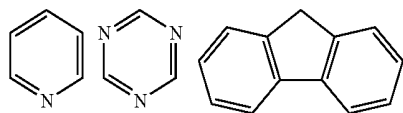
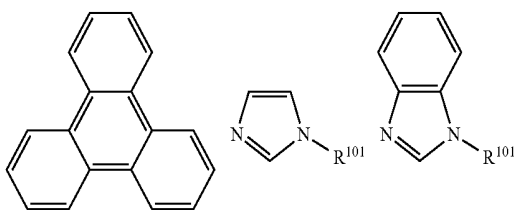

192

-continued

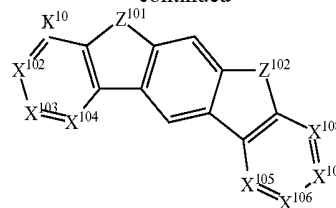

5

10

wherein  $R^{101}$  to  $R^{107}$  is independently selected from the group consisting of hydrogen, deuterium, halide, alkyl, cycloalkyl, heteroalkyl, arylalkyl, alkoxy, aryloxy, amino, silyl, alkenyl, cycloalkenyl, heteroalkenyl, alkynyl, aryl, heteroaryl, acyl, carbonyl, carboxylic acids, ester, nitrile, isonitrile, sulfanyl, sulfinyl, sulfonyl, phosphino, and combinations thereof, when it is aryl or heteroaryl, it has the similar definition as Ar's mentioned above.  $k$  is an integer from 0 to 20 or 1 to 20;  $k'''$  is an integer from 0 to 20.  $X^{101}$  to  $X^{108}$  is selected from C (including CH) or N.  $Z^{101}$  and  $Z^{102}$  is selected from  $NR^{101}$ , O, or S.

20

HBL:

A hole blocking layer (HBL) may be used to reduce the number of holes and/or excitons that leave the emissive layer. The presence of such a blocking layer in a device may result in substantially higher efficiencies as compared to a similar device lacking a blocking layer. Also, a blocking layer may be used to confine emission to a desired region of an OLED.

25

In one aspect, compound used in HBL contains the same molecule or the same functional groups used as host described above.

30

In another aspect, compound used in HBL contains at least one of the following groups in the molecule:

35

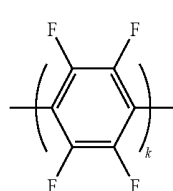

40

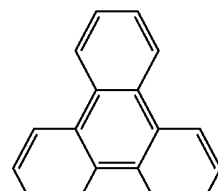

45

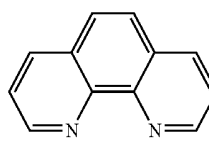

50

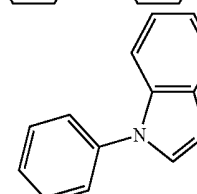

55

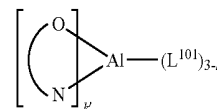
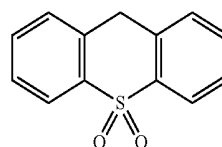

wherein  $k$  is an integer from 1 to 20;  $L^{101}$  is an another ligand,  $k'$  is an integer from 1 to 3.

60 ETL:

Electron transport layer (ETL) may include a material capable of transporting electrons. Electron transport layer may be intrinsic (undoped), or doped. Doping may be used to enhance conductivity. Examples of the ETL material are not particularly limited, and any metal complexes or organic compounds may be used as long as they are typically used to transport electrons.

65

In one aspect, compound used in ETL contains at least one of the following groups in the molecule:

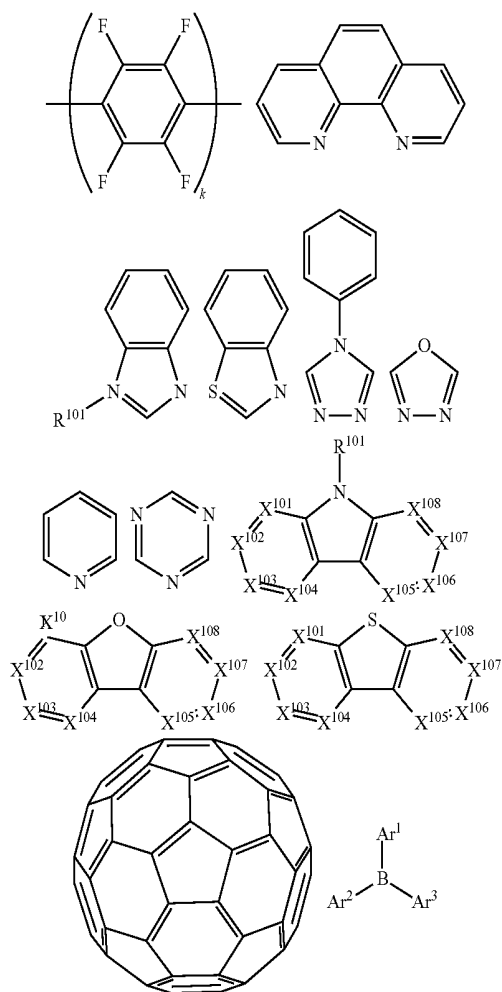

wherein R<sup>101</sup> is selected from the group consisting of hydrogen, deuterium, halide, alkyl, cycloalkyl, heteroalkyl, aryl-

alkyl, alkoxy, aryloxy, amino, silyl, alkenyl, cycloalkenyl, heteroalkenyl, alkynyl, aryl, heteroaryl, acyl, carbonyl, carboxylic acids, ester, nitrile, isonitrile, sulfanyl, sulfonyl, phosphino, and combinations thereof, when it is aryl or heteroaryl, it has the similar definition as Ar's mentioned above. Ar<sup>1</sup> to Ar<sup>3</sup> has the similar definition as Ar's mentioned above. k is an integer from 1 to 20. X<sup>101</sup> to X<sup>108</sup> is selected from C (including CH) or N.

In another aspect, the metal complexes used in ETL contains, but not limit to the following general formula:

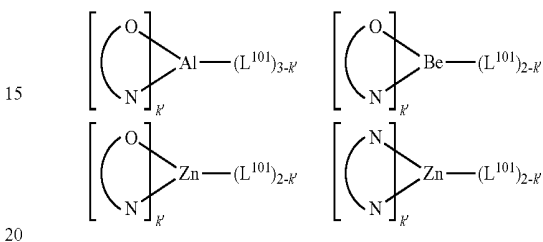

wherein (O—N) or (N—N) is a bidentate ligand, having metal coordinated to atoms O, N or N, N; L<sup>101</sup> is another ligand; k' is an integer value from 1 to the maximum number of ligands that may be attached to the metal.

In any above-mentioned compounds used in each layer of the OLED device, the hydrogen atoms can be partially or fully deuterated. Thus, any specifically listed substituent, such as, without limitation, methyl, phenyl, pyridyl, etc. encompasses undeuterated, partially deuterated, and fully deuterated versions thereof. Similarly, classes of substituents such as, without limitation, alkyl, aryl, cycloalkyl, heteroaryl, etc. also encompass undeuterated, partially deuterated, and fully deuterated versions thereof.

In addition to and/or in combination with the materials disclosed herein, many hole injection materials, hole transporting materials, host materials, dopant materials, exciton/hole blocking layer materials, electron transporting and electron injecting materials may be used in an OLED. Non-limiting examples of the materials that may be used in an OLED in combination with materials disclosed herein are listed in Table 5 below. Table 5 lists non-limiting classes of materials, non-limiting examples of compounds for each class, and references that disclose the materials.

TABLE 5

MATERIAL	EXAMPLES OF MATERIAL	PUBLICATIONS
Hole injection materials		

Phthalocyanine and porphyrin compounds

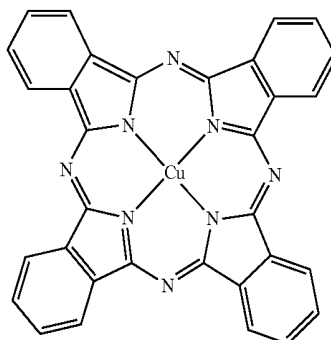

Appl. Phys. Lett. 69, 2160 (1996)

TABLE 5-continued

MATERIAL	EXAMPLES OF MATERIAL	PUBLICATIONS
Starburst triarylaminines		J. Lumin. 72-74, 985 (1997)
CF <sub>x</sub> Fluoro-hydrocarbon polymer	$\text{---}[\text{CH}_x\text{F}_y]_n\text{---}$	Appl. Phys. Lett. 78, 673 (2001)
Conducting polymers (e.g., PEDOT:PSS, polyaniline, polythiophene)		Synth. Met, 87, 171 (1997) WO2007002683
Phosphonic acid and silane SAMS		US20030162053
Triarylamine or polythiophene polymers with conductivity dopants		EP1725079A1
	and	

TABLE 5-continued

MATERIAL	EXAMPLES OF MATERIAL	PUBLICATIONS
----------	----------------------	--------------

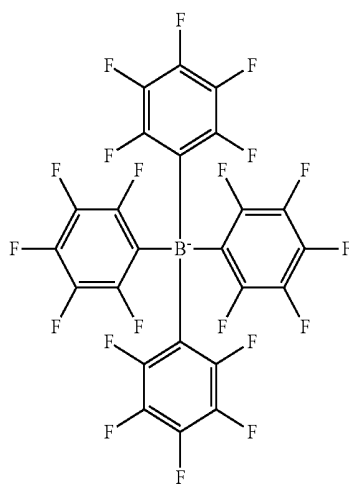
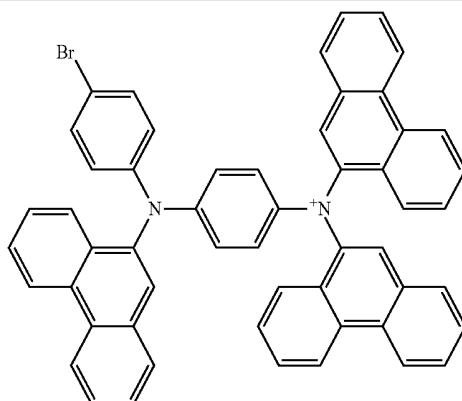

Organic compounds with conductive inorganic compounds, such as molybdenum and tungsten oxides

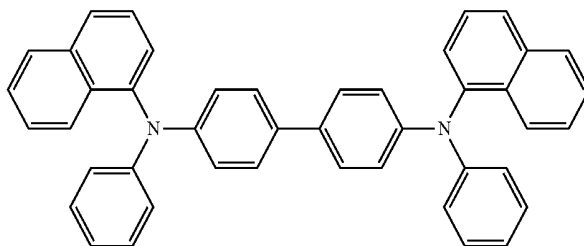

+ MoO<sub>x</sub>

US20050123751  
SID Symposium  
Digest, 37, 923 (2006)  
WO2009018009

n-type semi-conducting organic complexes

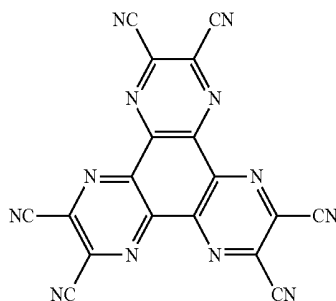

US20020158242

Metal organometallic complexes

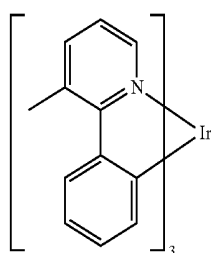

US20060240279

TABLE 5-continued

MATERIAL	EXAMPLES OF MATERIAL	PUBLICATIONS
Cross-linkable compounds		US20080220265
Polythiophene based polymers and copolymers		WO 2011075644 EP2350216
Hole transporting materials		
Triarylamines (e.g., TPD, $\alpha$ -NPD)		Appl. Phys. Lett. 51, 913 (1987)
		U.S. Pat. No. 5,061,569

TABLE 5-continued

MATERIAL

EXAMPLES OF MATERIAL

PUBLICATIONS

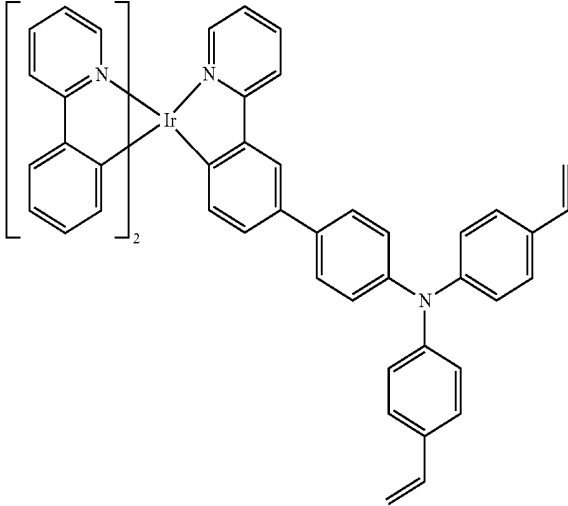
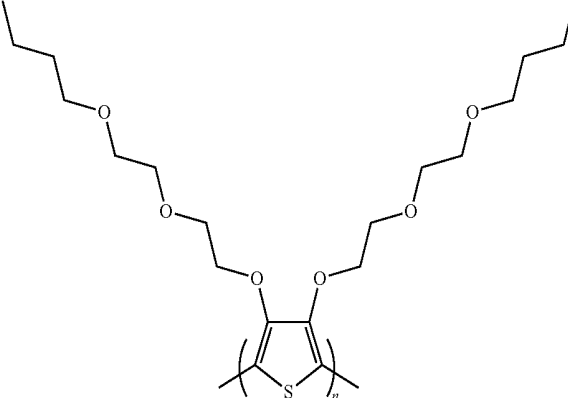
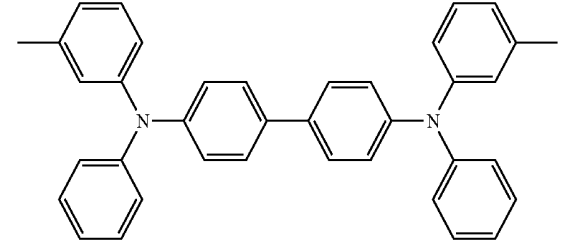
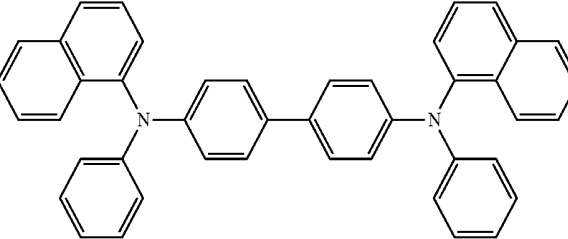
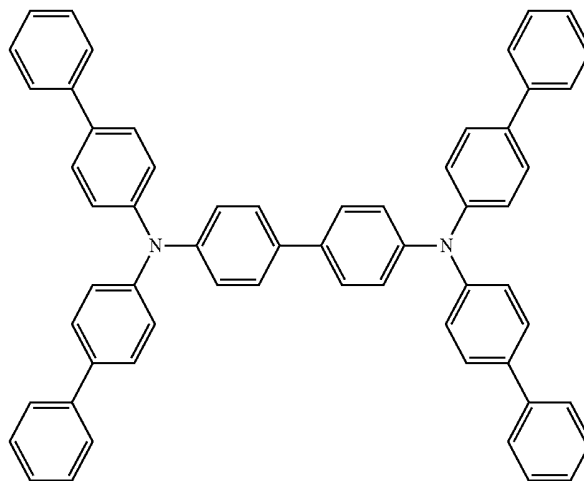

EP650955

J. Mater. Chem. 3, 319  
(1993)Appl. Phys. Lett. 90,  
183503 (2007)

TABLE 5-continued

MATERIAL	EXAMPLES OF MATERIAL	PUBLICATIONS
Triarylamine on spirofluorene core		Appl. Phys. Lett. 90, 183503 (2007)
Arylamine carbazole compounds		Adv. Mater. 6, 677 (1994), US20080124572
Triarylamine with (di)benzothiophene/ (di)benzofuran		US20070278938, US20080106190 US20110163302

TABLE 5-continued

MATERIAL	EXAMPLES OF MATERIAL	PUBLICATIONS
Indolocarbazotes		Synth. Met. 111, 421 (2000)
Isoindole compounds		Chem. Mater. 15, 3148 (2003)
Metal carbene complexes		US20080018221
Phosphorescent OLED host materials Red hosts		
Arylcarbazoles		Appl. Phys. Lett. 78, 1622 (2001)

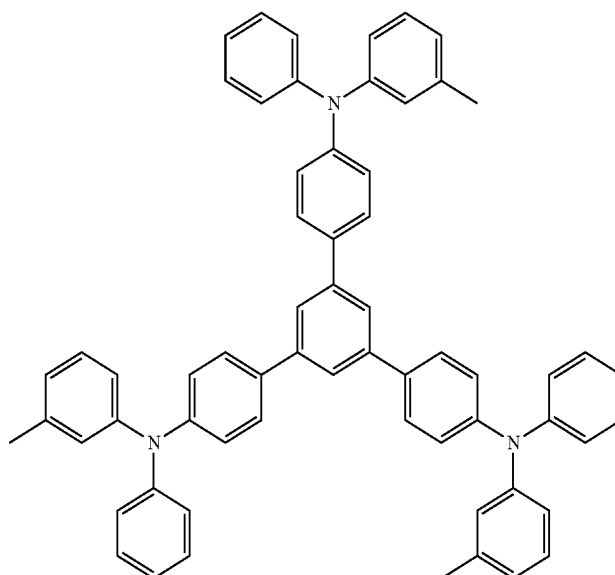
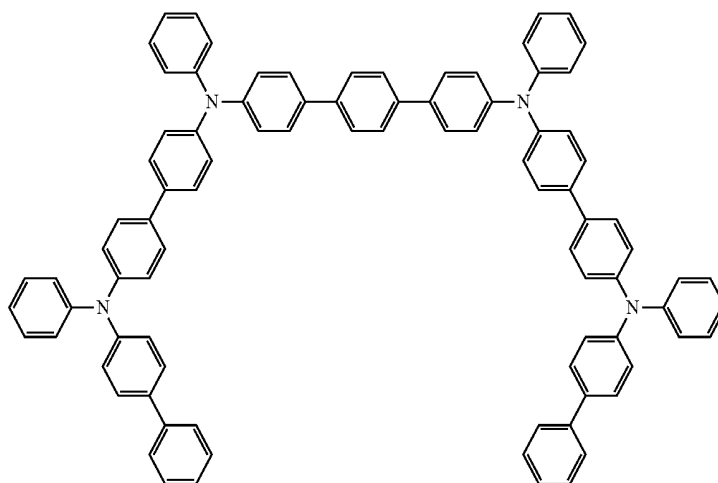
TABLE 5-continued

MATERIAL	EXAMPLES OF MATERIAL	PUBLICATIONS
Metal 8-hydroxyquinolates (e.g., Alq <sub>3</sub> , BALq)		Nature 395, 151 (1998)
		US20060202194
		WO2005014551
		WO2006072002
Metal phenoxy-benzothiazole compounds		Appl. Phys. Lett. 90, 123509 (2007)
Conjugated oligomers and polymers (e.g., polyfluorene)		Org. Electron. 1, 15 (2000)
Aromatic fused rings		WO2009066779, WO2009066778, WO2009063833, US20090045731, US20090045730, WO2009008311, US20090008605, US20090009065

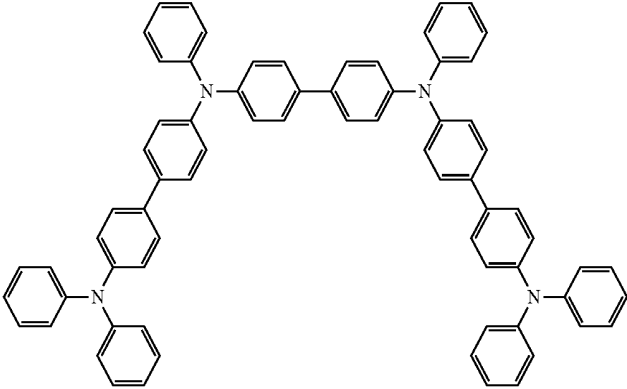
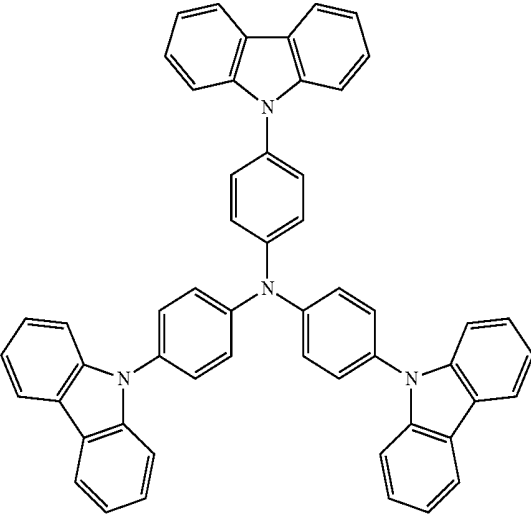
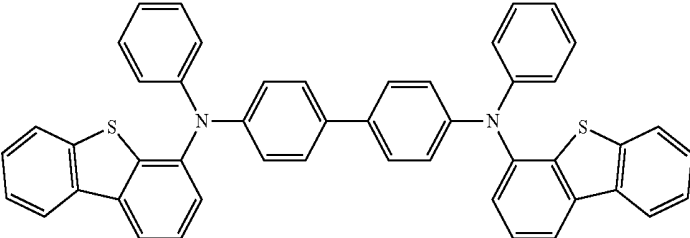
TABLE 5-continued

MATERIAL	EXAMPLES OF MATERIAL	PUBLICATIONS
Zinc complexes		WO2010056066
Chrysene based compounds		WO2011086863
Green hosts		
Arylcarbazoles		Appl. Phys. Lett. 78, 1622 (2001)
		US20030175553
		WO2001039234
Aryltriphenylene compounds		US20060280965

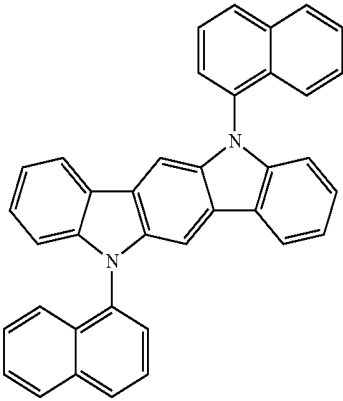
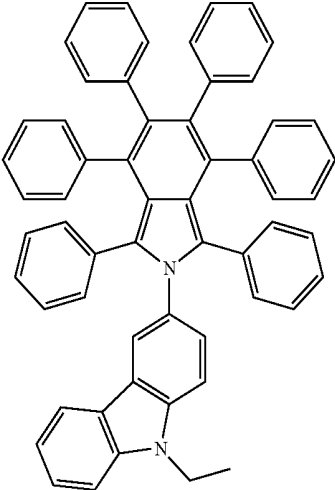
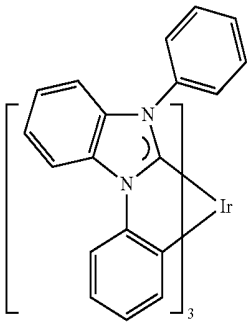
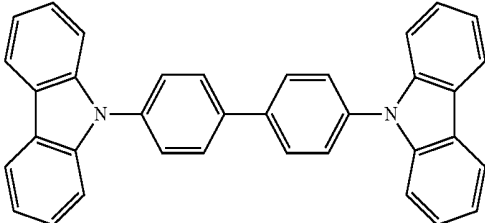
TABLE 5-continued

MATERIAL	EXAMPLES OF MATERIAL	PUBLICATIONS
		US20060280965
		WO2009021126
Poly-fused heteroaryl compounds		US20090309488 US20090302743 US20100012931
Donor acceptor type molecules		WO2008056746
		WO2010107244

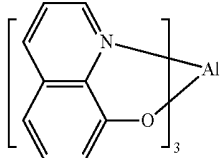
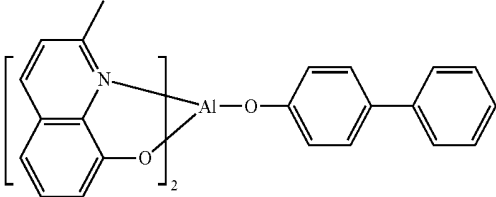
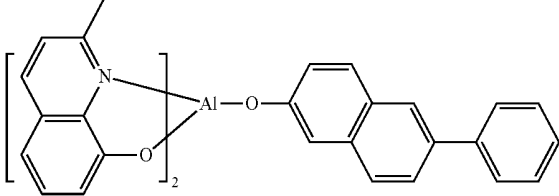
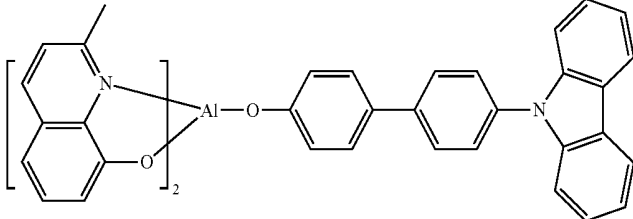
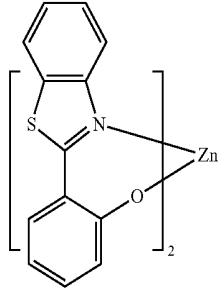
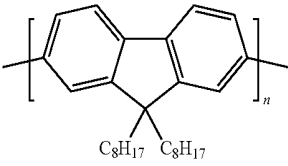
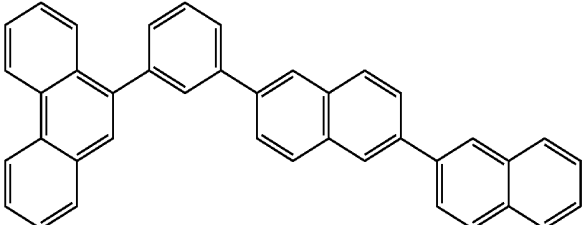
TABLE 5-continued

MATERIAL	EXAMPLES OF MATERIAL	PUBLICATIONS
Azacarbazole/ DBT/DBF		JP2008074939
		US20100187984
Polymers (e.g., PVK)		Appl Phys, Lett. 77, 2280 (2000)
Spirofluorene compounds		WO2004093207
Metal phenoxy- benzoxazole compounds		WO2005089025

TABLE 5-continued

MATERIAL	EXAMPLES OF MATERIAL	PUBLICATIONS
		WO2006132173
		JP200511610
Spirofluorene-carbazole compounds		JP2007254297
		JP2007254297
Indolocabazoles		WO2007063796

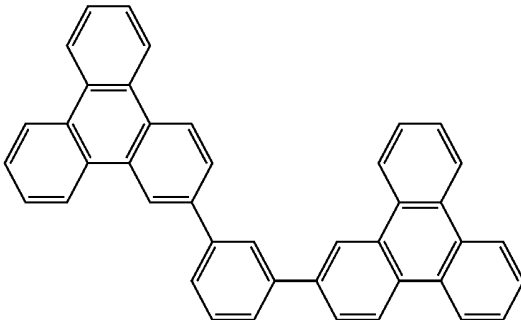
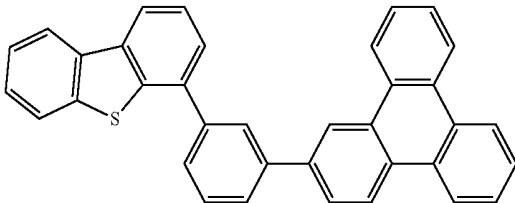
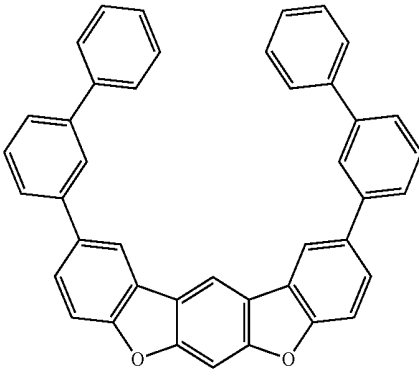
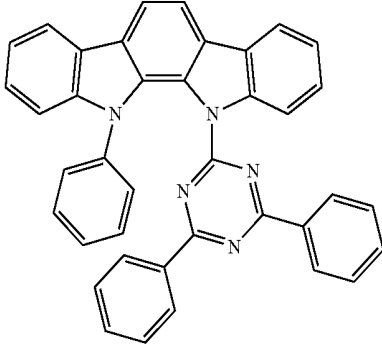
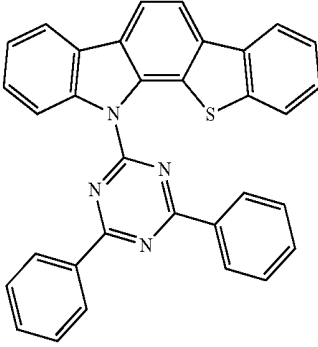
TABLE 5-continued

MATERIAL	EXAMPLES OF MATERIAL	PUBLICATIONS
5-member ring electron deficient heterocycles (e.g., triazole, oxadiazole)	 	WO2007063754  J. Appl. Phys. 90, 5048 (2001)
Tetraphenylene complexes	 	WO2004107822  US20050112407
Metal phenoxy-pyridine compounds		WO2005030900

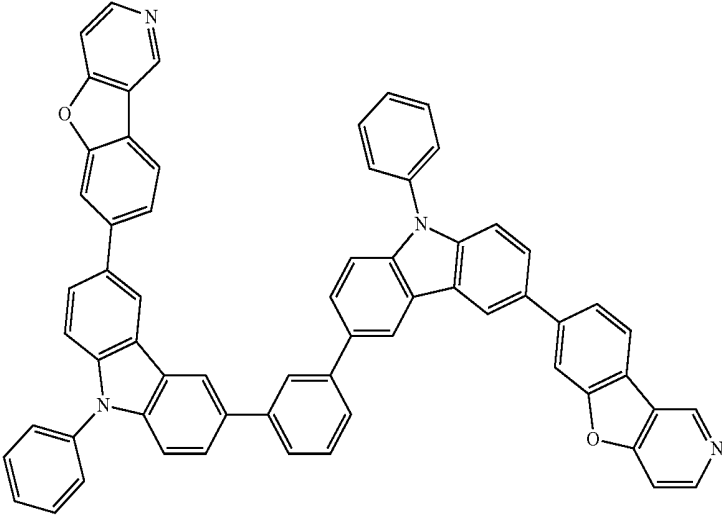
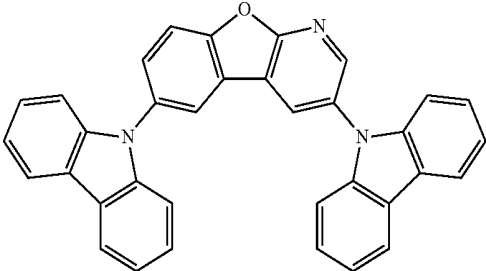
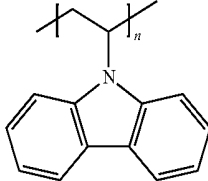
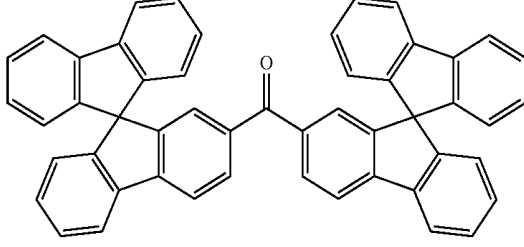
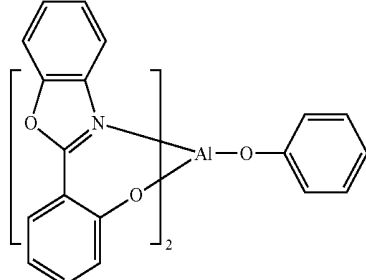
TABLE 5-continued

MATERIAL	EXAMPLES OF MATERIAL	PUBLICATIONS
Metal coordination complexes (e.g., Zn, Al with with (N N) ligands)		US20040137268, US20040137267
Blue hosts		
Arylcarbazoles		Appl. Phys. Lett., 82, 2422 (2003)
		US20070190359
Dibenzothiophene/ Dibenzofuran- carbazole compounds		WO2006114966, US20090167162
		US20090167162
		WO2009086028

TABLE 5-continued

MATERIAL	EXAMPLES OF MATERIAL	PUBLICATIONS
		US20090030202, US20090017330
		US20100084966
Silicon aryl compounds		US20050238919
		WO2009003898
Silicon/ Germanium aryl compounds		EP2034538A
Aryl benzoyl ester		WO2006100298

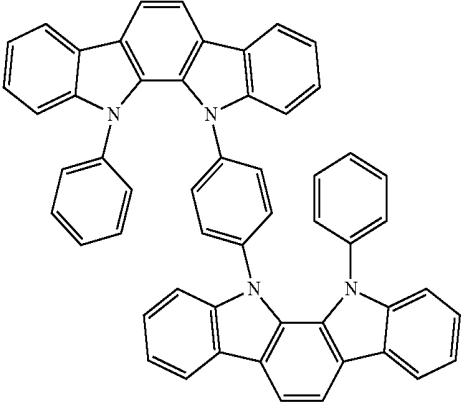
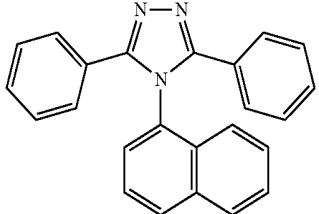
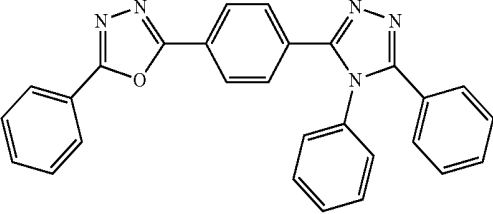
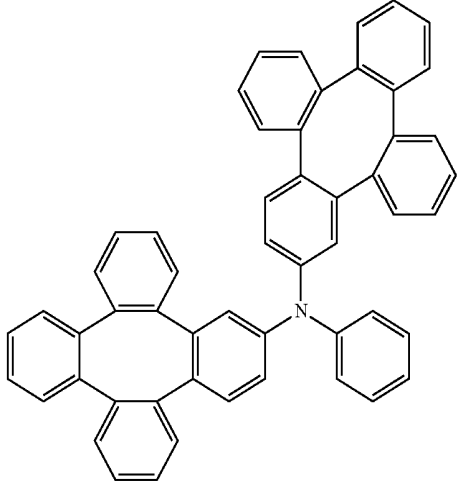
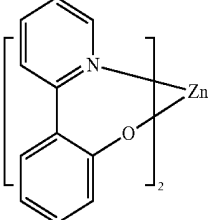
TABLE 5-continued

MATERIAL	EXAMPLES OF MATERIAL	PUBLICATIONS
Carbazole linked by non-conjugated groups		US20040115476
Aza-carbazoles		US20060121308
High triplet metal organometallic complex		U.S. Pat. No. 7,154,114
Phosphorescent dopants Red dopants		
Heavy metal porphyrins (e.g., PtOEP)		Nature 395. 151 (1998)
Iridium(III) organometallic complexes		Appl. Phys. Lett. 78, 1622 (2001)

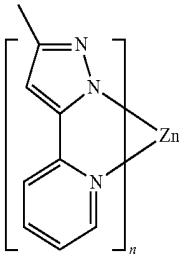
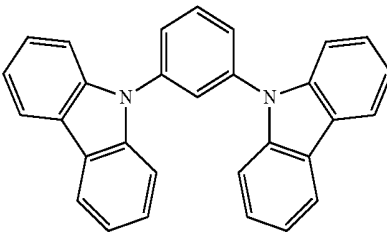
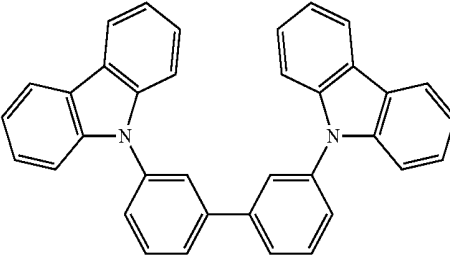
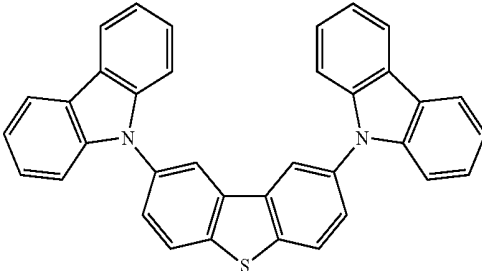
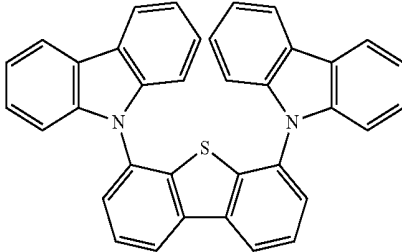
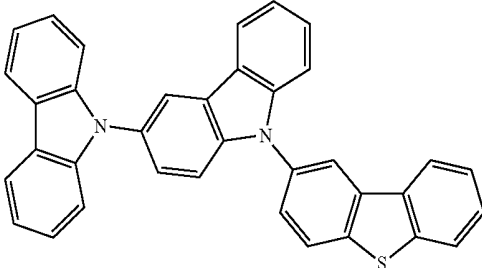
TABLE 5-continued

MATERIAL	EXAMPLES OF MATERIAL	PUBLICATIONS
		US20030072964
		US20030072964
		US20060202194
		US20060202194
		US20070087321

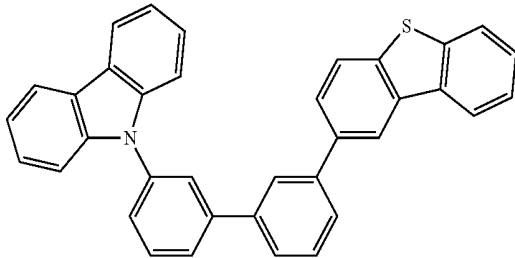
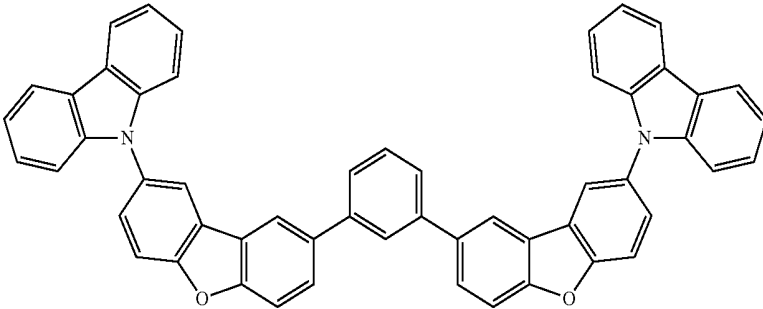
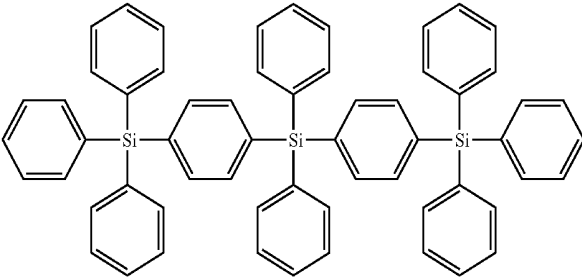
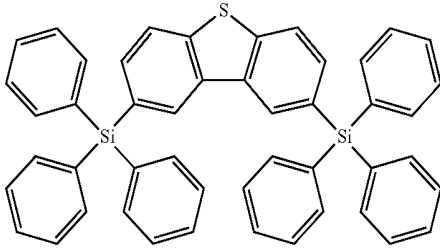
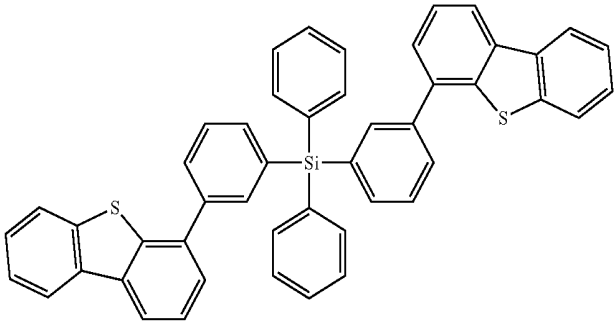
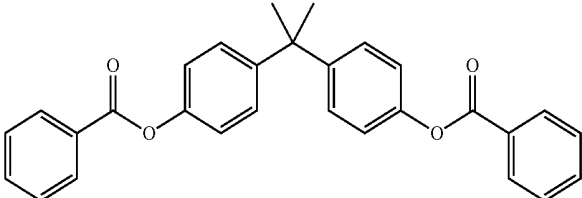
TABLE 5-continued

MATERIAL	EXAMPLES OF MATERIAL	PUBLICATIONS
		US20080261076 US20100090591
		US20070087321
	<p data-bbox="759 1256 807 1283">H<sub>17</sub>C<sub>8</sub></p>	Adv. Mater. 19, 739 (2007)
	<p data-bbox="943 1473 1002 1500">Ir(acac)</p>	WO2009100991
		WO2008101842

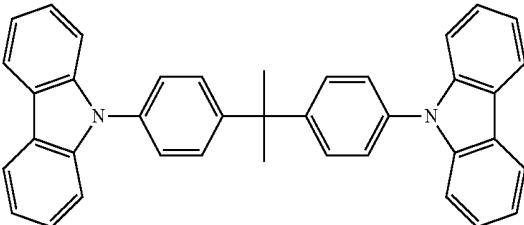
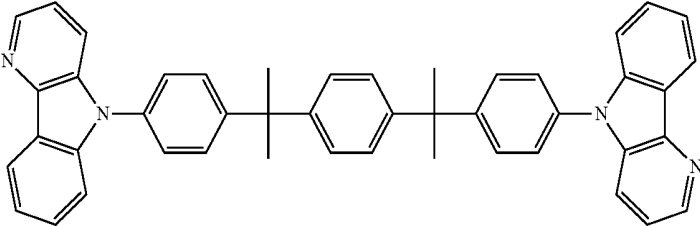
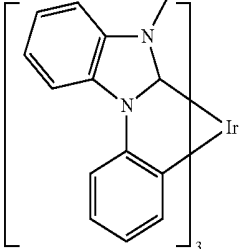
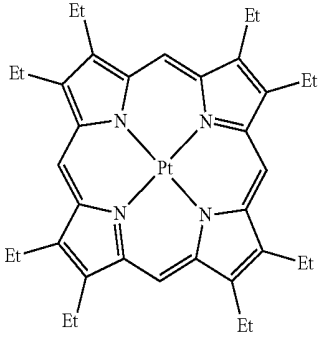
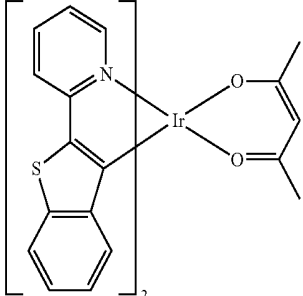
TABLE 5-continued

MATERIAL	EXAMPLES OF MATERIAL	PUBLICATIONS
Platinum(ii) organometallic complexes		U.S. Pat. No. 7,232,618
Ostaintim(III) complexes		WO2003040257
Ruthenium(II ) complexes		US20070103060
Rhenium (I), (II), and (III) complexes		Chem.. Mater. 17, 3532 (2005)
Ruthenium(II ) complexes		Adv. Mater. 17, 1059 (2005)
Rhenium (I), (II), and (III) complexes		US20050244673

TABLE 5-continued

MATERIAL	EXAMPLES OF MATERIAL	PUBLICATIONS
Iridium(III) organometallic complexes	Green dopants	
		Inorg. Chem. 40, 1704 (2001)
	and its derivative	
		US20020034656
		U.S. Pat. No. 7,332,232

TABLE 5-continued

MATERIAL	EXAMPLES OF MATERIAL	PUBLICATIONS
		US20090108737
		WO2010028151
		EP1841834B
		US20060127696
		US20090039776

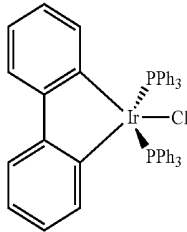
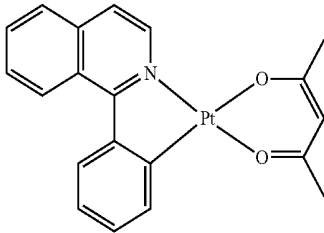
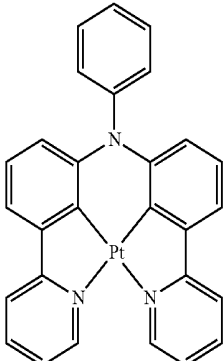
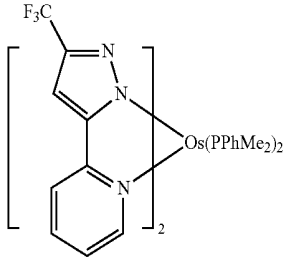
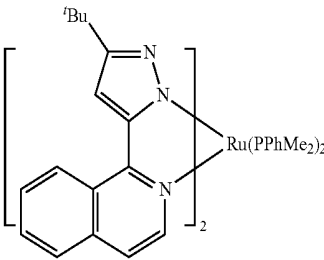
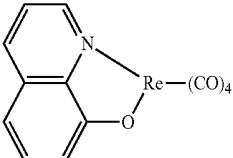
TABLE 5-continued

MATERIAL	EXAMPLES OF MATERIAL	PUBLICATIONS
		U.S. Pat. No. 6,921,915
		US20100244004
		U.S. Pat. No. 6,687,266
		Chem. Mater. 16, 2480 (2004)
		US20070190359

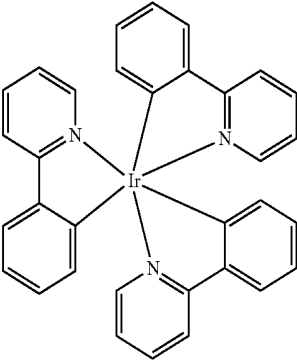
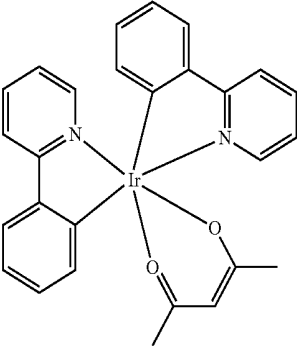
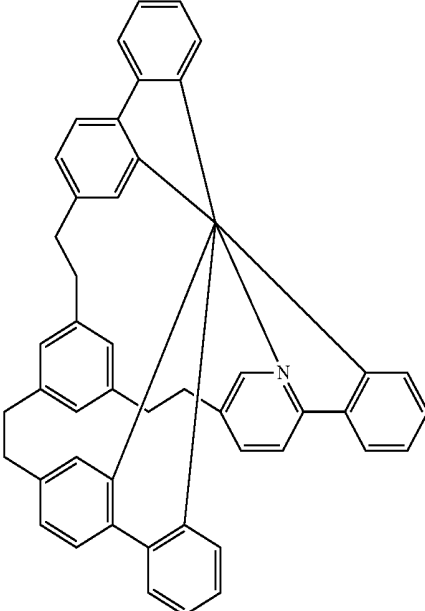
TABLE 5-continued

MATERIAL	EXAMPLES OF MATERIAL	PUBLICATIONS
		US 2006008670 JP2007123392
		WO2010086089, WO2011044988
		Adv. Mater. 16, 2003 (2004)
		Angew. Chem. Int. Ed. 2006, 45, 7800
		WO2009050290
		US20090165846

TABLE 5-continued

MATERIAL	EXAMPLES OF MATERIAL	PUBLICATIONS
		US20080015355
		US200101532
		US20100295032
Monomer for polymeric metal organometallic compounds		U.S. Pat. No. 7,250,226, U.S. Pat. No. 7,396,598
Pt(II) organometallic complexes, including polydentate ligands		Appl. Phys. Lett., 86, 153505 (2005)

TABLE 5-continued

MATERIAL	EXAMPLES OF MATERIAL	PUBLICATIONS
	<p>The structure shows a central platinum atom coordinated to three nitrogen atoms of a terpyridine-like ligand and one oxygen atom of a phenyl group.</p>	Appi. Phys. Lett. 86, 153505 (2005)
	<p>The structure shows a central platinum atom coordinated to two nitrogen atoms of a terpyridine-like ligand and two pentafluorophenyl groups (F<sub>5</sub>).</p>	Chem. Lett. 34, 592 (2005)
	<p>The structure shows a central platinum atom coordinated to two nitrogen atoms of a terpyridine-like ligand and two oxygen atoms of a 2,6-dimethylpyridine-3,5-dione ligand.</p>	WO2002015645
	<p>The structure shows a central platinum atom coordinated to two nitrogen atoms of a terpyridine-like ligand and two phenyl groups (Ph).</p>	US20060263635
	<p>The structure shows a central platinum atom coordinated to three nitrogen atoms of a terpyridine-like ligand and one phenyl group.</p>	US20060182992 US20070103060

TABLE 5-continued

MATERIAL	EXAMPLES OF MATERIAL	PUBLICATIONS
Cu complexes		WO2009000673
		US20070111026
Gold complexes		Chem. Commun. 2906 (2005)
Rhenium(III) complexes		Inorg. Chem. 42, 1248 (2003)

TABLE 5-continued

MATERIAL	EXAMPLES OF MATERIAL	PUBLICATIONS
Osmium(II) complexes		U.S. Pat. No. 7,279,704
Deuterated organometallic complexes		US20030138657
Organometallic complexes with two or more metal centers		US20030152802
		U.S. Pat. No. 7,090,928

TABLE 5-continued

MATERIAL	EXAMPLES OF MATERIAL	PUBLICATIONS
Iridium(III) organometallic complexes		WO2002002714
		WO2006009024
		US20060251923 US20110057559 US20110204333
		U.S. Pat. No. 7,393,599, WO2006056418, US20050260441, WO2005019373
		U.S. Pat. No. 7,534,505
		WO2011051404

TABLE 5-continued

MATERIAL	EXAMPLES OF MATERIAL	PUBLICATIONS
		U.S. Pat. No. 7,445,855
		US20070190359, US20080297033 US20100148663
		U.S. Pat. No. 7,338,722
		US20020134984
		Angew. Chem. Int. Ed. 47, 4542 (2008)

TABLE 5-continued

MATERIAL	EXAMPLES OF MATERIAL	PUBLICATIONS
		Chem. Mater. 18, 5119 (2006)
		Inorg. Chem. 46, 4308 (2007)
		WO2005123873
		WO2005123873
		WO2007004380

TABLE 5-continued

MATERIAL	EXAMPLES OF MATERIAL	PUBLICATIONS
Osmium(II) complexes		WO2006082742
Gold complexes		U.S. Pat. No. 7,279,704
Platinum(II) complexes		Organometallics 23, 3745 (2004)
Platinum(II) complexes		Appl. Phys. Lett. 74, 1361 (1999)

TABLE 5-continued

MATERIAL	EXAMPLES OF MATERIAL	PUBLICATIONS
Pt tetradentate complexes with at least one metal-carbene bond		U.S. Pat. No. 7,655,323
Exciton/hole blocking layer materials		
Bathocuprine compounds (e.g., BCP, BPhen)		Appl. Phys. Lett. 75, 4 (1999)
		Appl. Phys. Lett. 79, 449 (2001)
Metal 8-hydroxy-quinolates (e.g., BALq)		Appl. Phys. Lett. 81, 162 (2002)
5-member ring electron deficient heterocycles such as triazole, oxadiazole, imidazole, benzoimidazole		Appl. Phys. Lett. 81, 162 (2002)

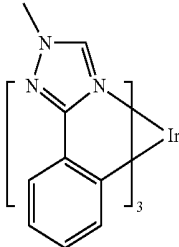
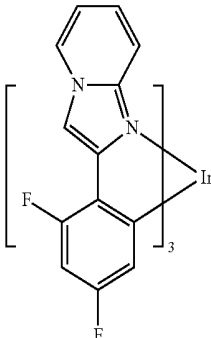
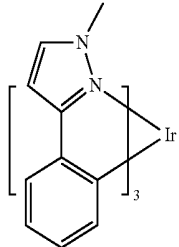
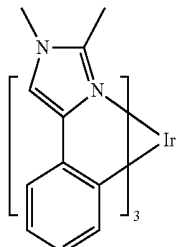
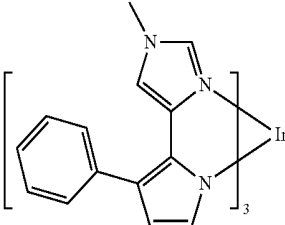
TABLE 5-continued

MATERIAL	EXAMPLES OF MATERIAL	PUBLICATIONS
Triphenylene compounds		US20050025993
Fluorinated aromatic compounds		Appl. Phys. Lett. 79, 156 (2001)
Phenothiazine-S-oxide		WO2008132085
Silylated five-membered nitrogen, oxygen, sulfur or phosphorus dibenzoheterocycles		WO2010079051

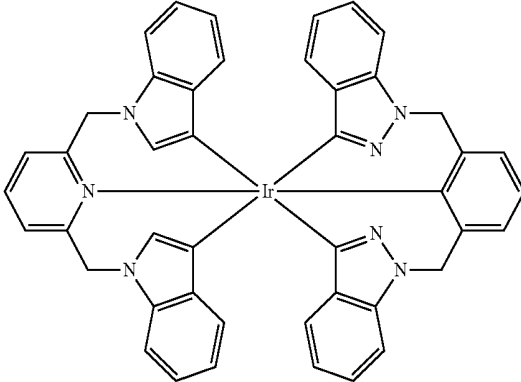
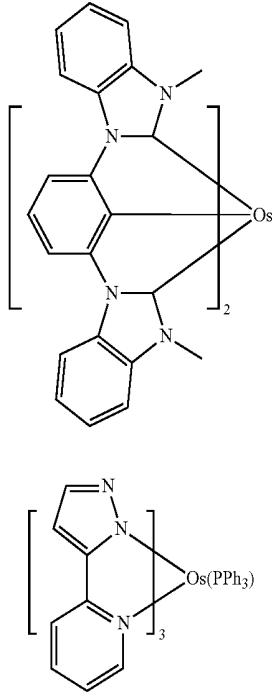
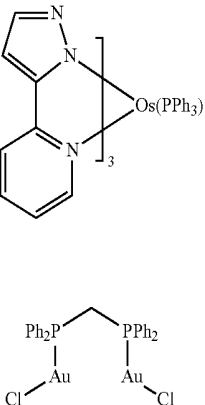
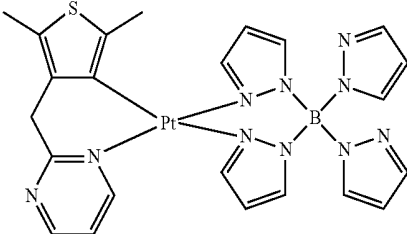
TABLE 5-continued

MATERIAL	EXAMPLES OF MATERIAL	PUBLICATIONS
Aza-carbazoles		US20060121308
Electron transporting materials		
Anthracene-benzimidazole compounds		WO2003060956
		US20090179554
Aza triphenylene derivatives		US20090115316
Anthracene-benzothiazole compounds		Appl. Phys. Lett. 89, 063504 (2006)

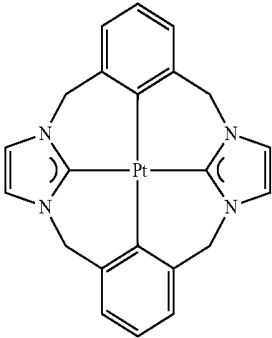
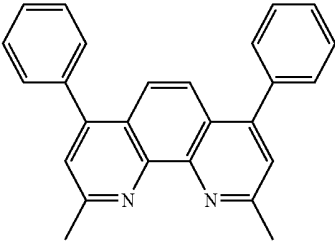
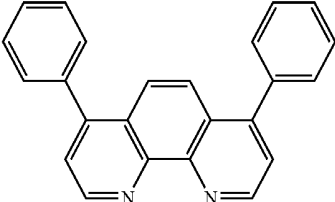
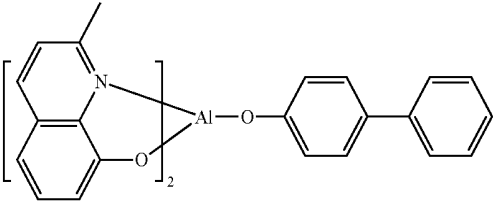
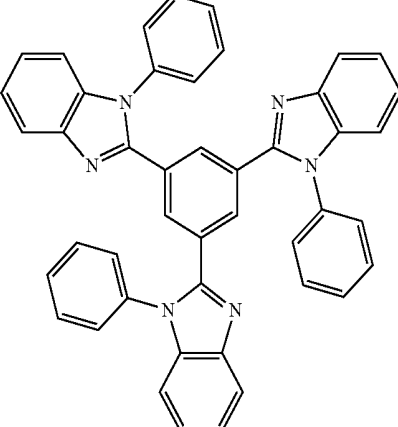
TABLE 5-continued

MATERIAL	EXAMPLES OF MATERIAL	PUBLICATIONS
Metal 8-hydroxy-quinolates (e.g., Alq <sub>3</sub> Zrq <sub>4</sub> )		Appl. Phys. Lett. 51, 913 (1987) U.S. Pat. No. 7,230,107
Metal hydroxy-benzoquinolates		Chem. Lett. 5, 905 (1993)
Bathocuprine compounds such as BCP, BPhen, etc		Appl. Phys. Lett. 91, 263503 (2007)
		Appl. Phys. Lett. 79, 449 (2001)
5-member ring electron deficient heterocycles (e.g., triazole, oxadiazole, imidazole, benzoimidazole)		Appl. Phys. Lett. 74, 865 (1999)
		Appl. Phys. Lett. 55, 1489 (1989)

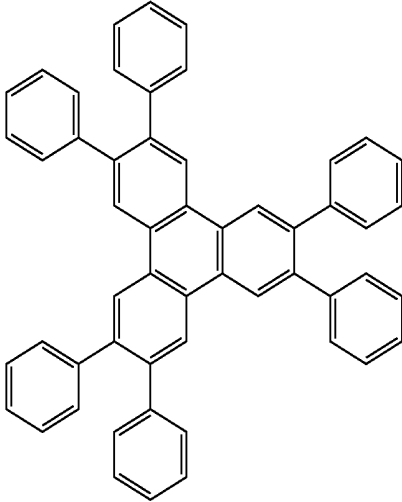
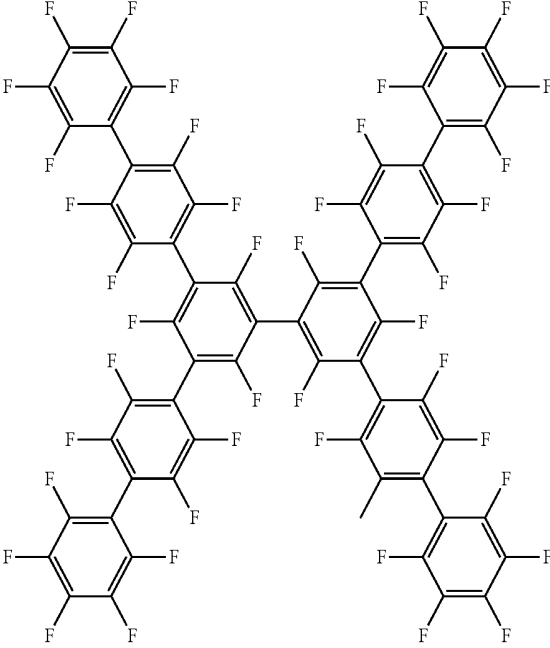
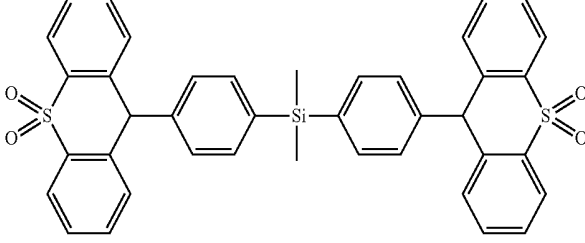
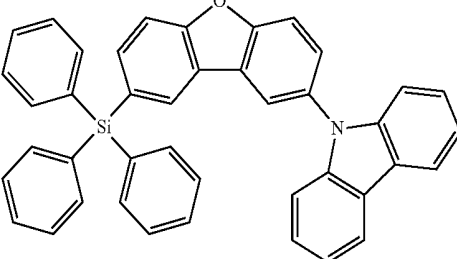
TABLE 5-continued

MATERIAL	EXAMPLES OF MATERIAL	PUBLICATIONS
Silole compounds		Jpn. J. Apply. Phys. 32, L917 (1993)
Arylboration compounds		Org. Electron. 4, 113 (2003)
Fluorinated aromatic compounds		J. Am. Chem. Soc. 120, 9714 (1998)
Fullerene (e.g., C60)		US20090101870
Triazine complexes		US20040036077

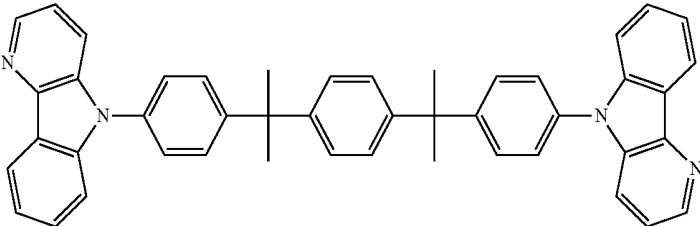
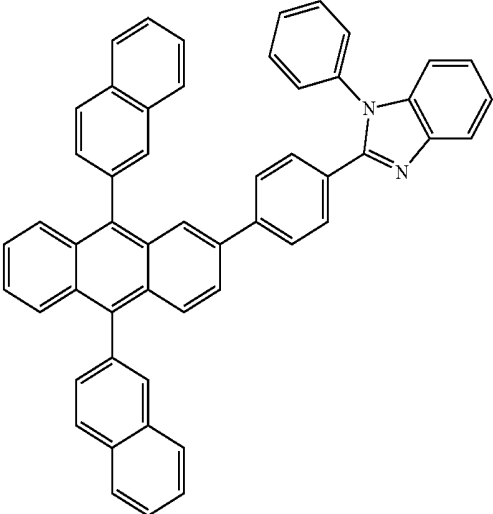
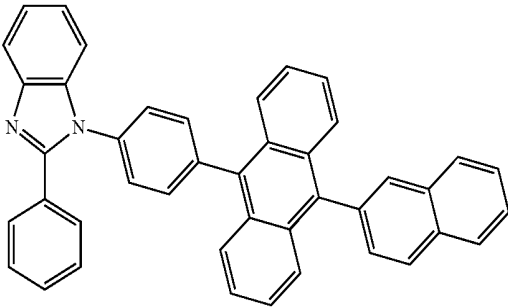
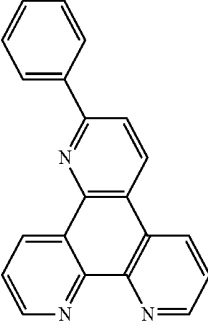
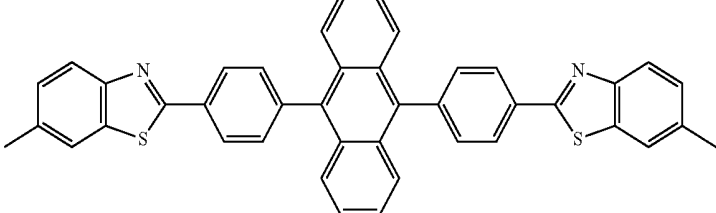
TABLE 5-continued

MATERIAL	EXAMPLES OF MATERIAL	PUBLICATIONS
Zn (N <sup>^</sup> N) complexes		U.S. Pat. No. 6,528,187

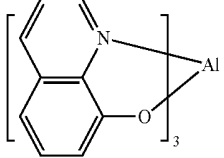
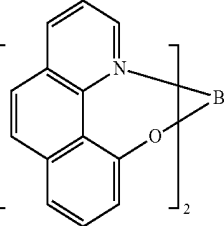
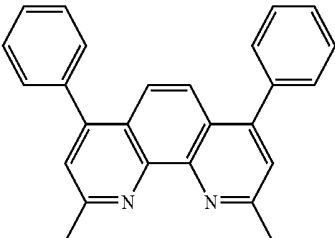
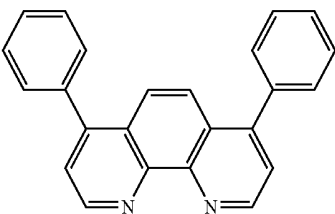
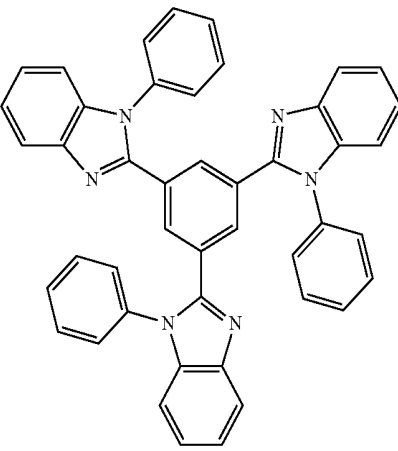
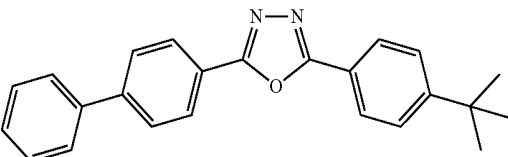
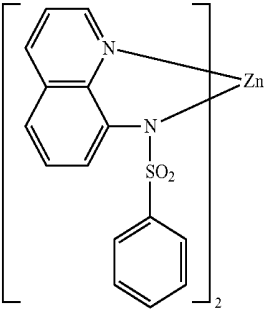
It is understood that the various embodiments described herein are by way of example only, and are not intended to limit the scope of the invention. For example, many of the materials and structures described herein may be substituted with other materials and structures without deviating from the spirit of the invention. The present invention as claimed may therefore include variations from the particular examples and preferred embodiments described herein, as will be apparent to one of skill in the art. It is understood that various theories as to why the invention works are not intended to be limiting.

What is claimed is:

1. A composition comprising: a mixture of a first compound and a second compound;

wherein the first compound has a different chemical structure than the second compound;

wherein the first compound is capable of functioning as a phosphorescent emitter in an organic light emitting device at room temperature;

wherein the first compound has an evaporation temperature T1 of 150 to 350° C.;

wherein the second compound has an evaporation temperature T2 of 150 to 350° C., wherein the evaporation temperature of a compound is measured in a vacuum deposition tool at a constant pressure, between  $1 \times 10^{-7}$  Torr to  $1 \times 10^{-8}$  Torr, at a 2 Å/sec deposition rate on a surface positioned at a set distance away from the evaporating compound;

wherein the absolute value of T1-T2 is less than 20° C.;

wherein the first compound has a concentration C1 in said mixture and a concentration C2 in a film formed by evaporating the mixture in a vacuum deposition tool at a constant pressure between  $1 \times 10^{-6}$  Torr to  $1 \times 10^{-9}$  Torr, at a 2 Å/sec deposition rate on a surface position at a predefined distance away from the mixture being evaporated; and

wherein the absolute value of (C1-C2)/C1 is less than 5%;

wherein the first compound has a structure according to Formula I:

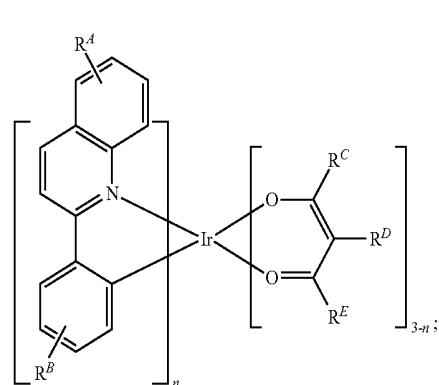

35 wherein

R<sup>A</sup> represents mono, di, tri, tetra, penta, hexa substitutions, or no substitution;

R<sup>B</sup> represents mono, di, tri, tetra substitutions, or no substitution;

R<sup>A</sup>, R<sup>B</sup>, R<sup>C</sup>, R<sup>D</sup>, and R<sup>E</sup> are each independently selected from the group consisting of hydrogen, deuterium, halogen, alkyl, cycloalkyl, heteroalkyl, arylalkyl, alkoxy, aryloxy, amino, cyclic amino, silyl, alkenyl, cycloalkenyl, heteroalkenyl, alkynyl, aryl, heteroaryl, acyl, carbonyl, carboxylic acid, ether, ester, nitrile, isonitrile, sulfanyl, sulfinyl, sulfonyl, phosphino, and combinations thereof;

wherein n is 1 or 2;

wherein the second compound has a structure according to Formula II:

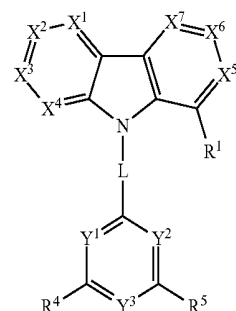

267

wherein  $X^1$ ,  $X^2$ ,  $X^3$ ,  $X^4$ ,  $X^5$ ,  $X^6$ ,  $X^7$ ,  $Y^1$ ,  $Y^2$ , and  $Y^3$  are each independently selected from the group consisting of CR and N;

wherein at least two of  $Y^1$ ,  $Y^2$ , and  $Y^3$  are N; and wherein  $R^1$ ,  $R^4$  and  $R^5$  are independently selected from group consisting of non-fused aryl, non-fused heteroaryl, and combinations thereof;

wherein L is selected from the group consisting of a direct bond, non-fused aryl, non-fused heteroaryl, and combinations thereof; and

wherein each R is independently selected from the group consisting of hydrogen, deuterium, non-fused aryl, non-fused heteroaryl and combinations thereof.

2. The composition of claim 1, wherein the first compound has a vapor pressure of P1 at T1 at 1 atm, the second compound has a vapor pressure of P2 at T2 at 1 atm; and wherein the ratio of P1/P2 is within the range of 0.90 to 1.10.

3. The composition of claim 1, wherein the first compound has a first mass loss rate and the second compound has a second mass loss rate, wherein the ratio between the first mass loss rate and the second mass loss rate is within the range of 0.90 to 1.10.

4. The composition of claim 1, wherein the phosphorescent emitter is capable of emitting light from a triplet excited state to a ground singlet state at room temperature.

5. The composition of claim 1, wherein the second compound is capable of functioning as a host in an organic light emitting device at room temperature.

6. The composition of claim 1, wherein the composition is in liquid form at a temperature less than T1 and T2.

7. The composition of claim 1, wherein  $R^1$  is selected from the group consisting of phenyl, biphenyl, terphenyl, tetraphenyl, pentaphenyl, pyridine, phenyl pyridine and pyridyl phenyl.

8. The composition of claim 1, wherein L is selected from the group consisting of phenyl, pyridyl, biphenyl, terphenyl and a direct bond.

9. The composition of claim 1, wherein  $R^4$  and  $R^5$  are each independently selected from the group consisting of phenyl, pyridyl, biphenyl, and terphenyl.

10. The composition of claim 1, wherein the second compound has a structure according to Formula III:

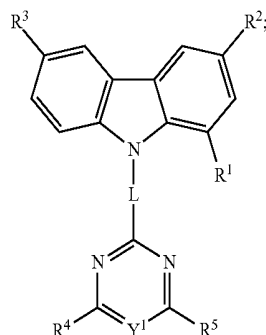

Formula III

wherein  $R^2$  and  $R^3$  are each independently selected from the group consisting of hydrogen, deuterium, halogen, alkyl, cycloalkyl, heteroalkyl, arylalkyl, alkoxy, aryloxy, amino, cyclic amino, silyl, alkenyl, cycloalkenyl, heteroalkenyl, alkynyl, aryl, heteroaryl, acyl, carbonyl, carboxylic acid, ether, ester, nitrile, isonitrile, sulfanyl, sulfinyl, sulfonyl, phosphino, and combinations thereof.

268

11. The composition of claim 10, wherein  $R^2$  and  $R^3$  are each independently selected from the group consisting of hydrogen, deuterium, non-fused aryl, non-fused heteroaryl and combinations thereof.

12. The composition of claim 10, wherein the second compound has a structure selected from the group consisting of:

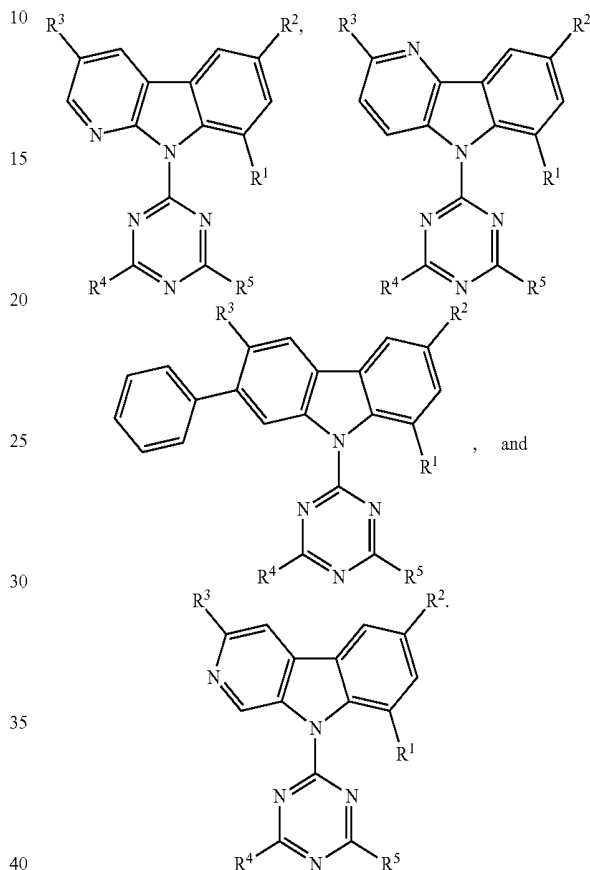

13. The composition of claim 1, wherein n is 1.

14. The composition of claim 1, wherein  $R^A$ ,  $R^B$ ,  $R^C$ ,  $R^D$ , and  $R^E$  are each independently selected from the group consisting of hydrogen, deuterium, alkyl, cycloalkyl, and combinations thereof.

15. The composition of claim 1, wherein at least one of  $R^C$  and  $R^E$  contains a branched alkyl moiety with branching at a position further than the  $\alpha$  position to the carbonyl group.

16. The composition of claim 1, wherein  $R^D$  is hydrogen.

17. The composition of claim 1, wherein at least one of  $R^C$  and  $R^E$  has the following structure:

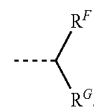

wherein  $R^F$ , and  $R^G$  are independently selected from group consisting of alkyl and cycloalkyl; and wherein at least one of  $R^F$ , and  $R^G$  has at least two C.

18. The composition of claim 1, wherein the first compound has a structure according to Formula IV:

269

Formula IV

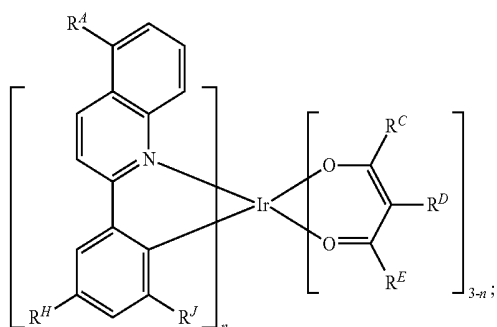

wherein  $R^H$  and  $R^J$  are each independently selected from the group consisting of hydrogen, deuterium, halogen, alkyl, cycloalkyl, heteroalkyl, arylalkyl, alkoxy, aryloxy, amino, cyclic amino, silyl, alkenyl, cycloalkenyl, heteroalkenyl, alkynyl, aryl, heteroaryl, acyl, carbonyl, carboxylic acid, ether, ester, nitrile, isonitrile, sulfanyl, sulfinyl, sulfonyl, phosphino, and combinations thereof.

19. The composition of claim 18, wherein  $R^H$  and  $R^J$  are each independently selected from the group consisting of hydrogen, deuterium, alkyl, cycloalkyl, and combinations thereof.

20. The composition of claim 18, wherein  $R^H$  and  $R^J$  are methyl.

21. The composition of claim 1, wherein the second compound is selected from the group consisting of:

270

-continued

Compound H3

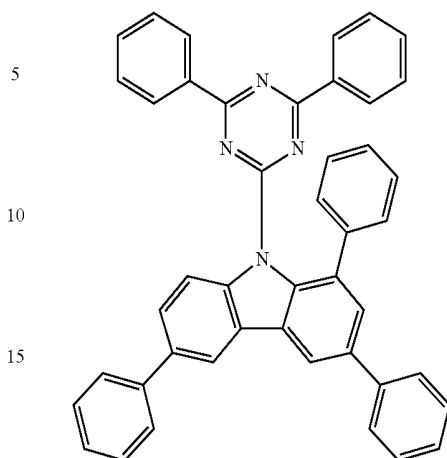

Compound H4

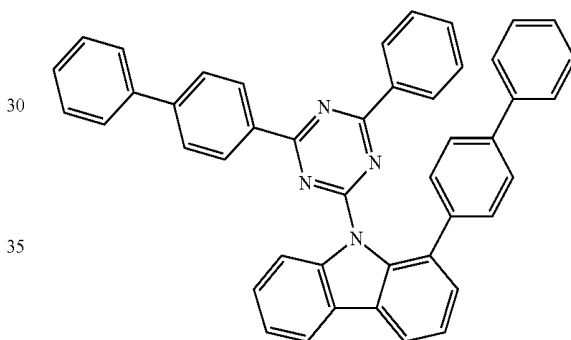

Compound H1

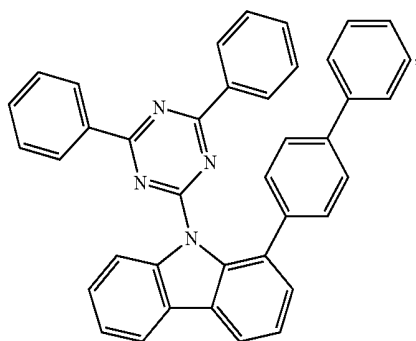

Compound H2

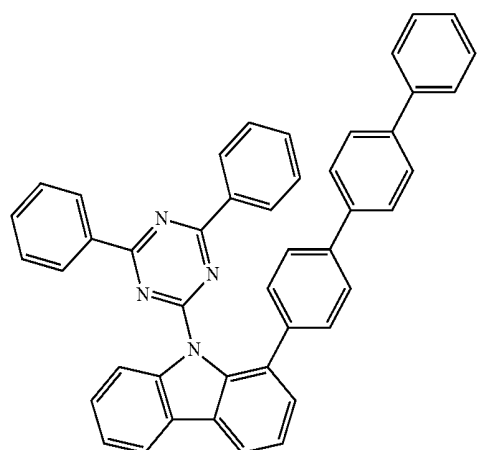

Compound H5

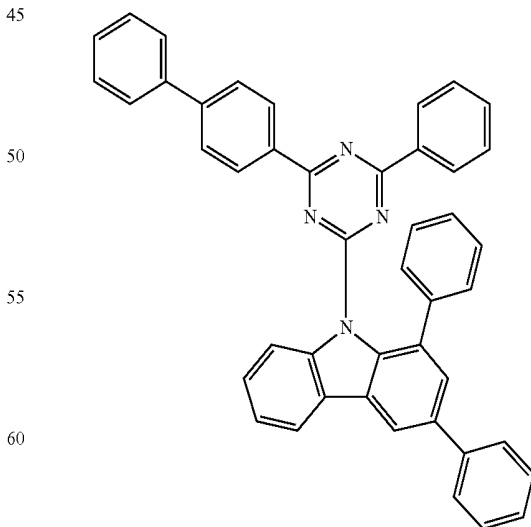

271  
-continued

Compound H6

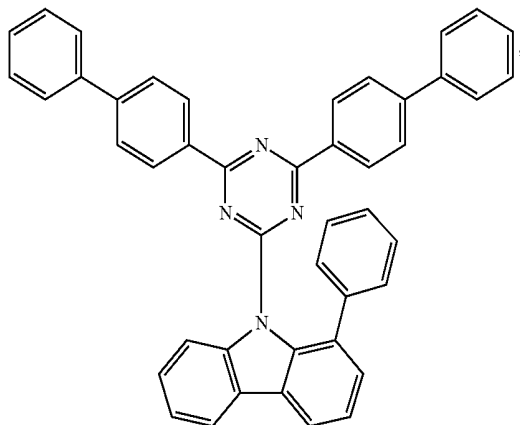

272  
-continued

Compound H9

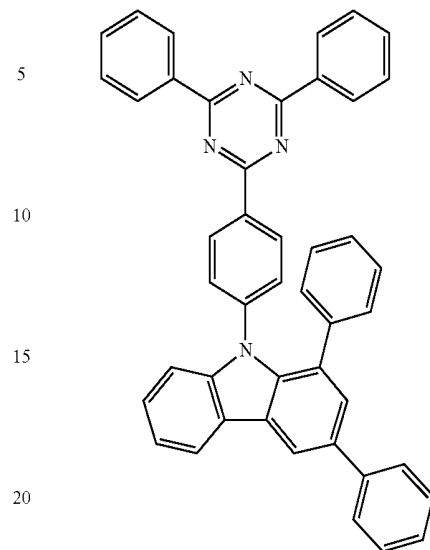

Compound H7

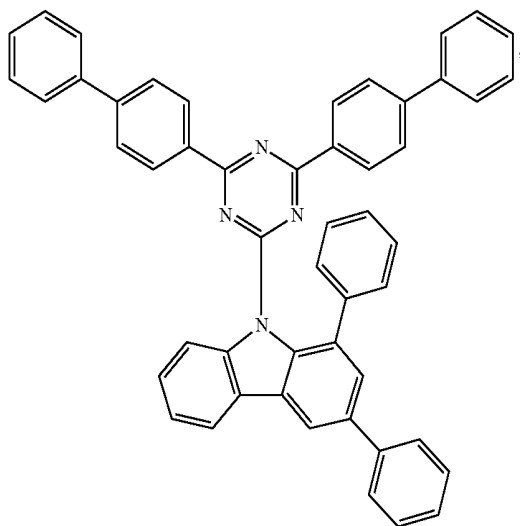

Compound H10

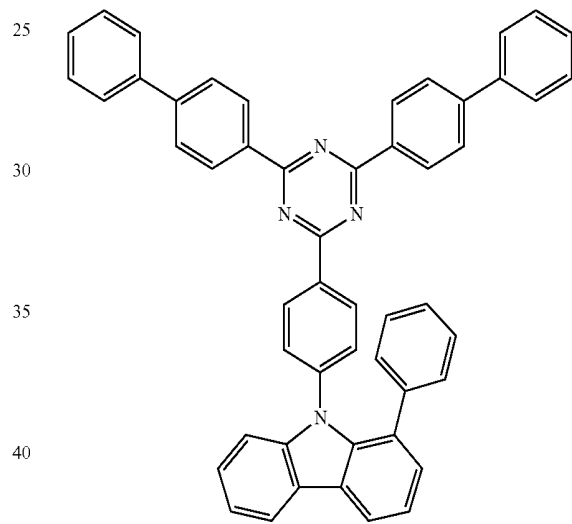

Compound H8

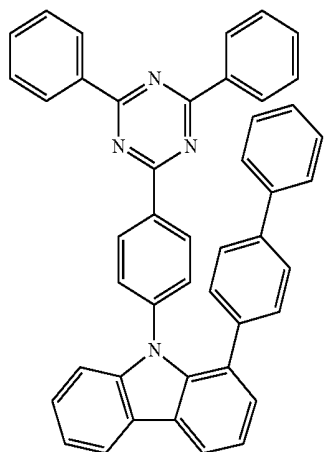

Compound H11

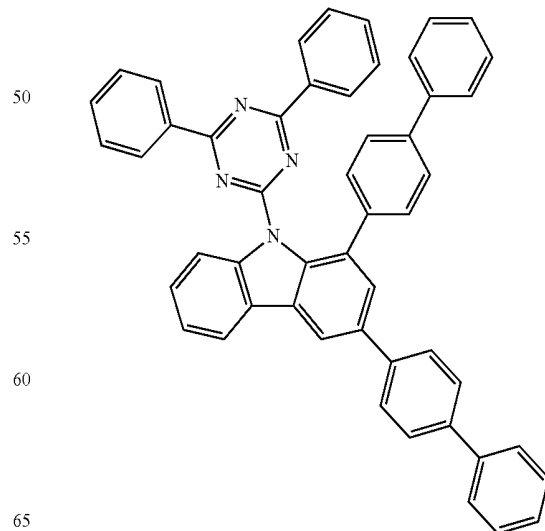

273  
-continued

Compound H12

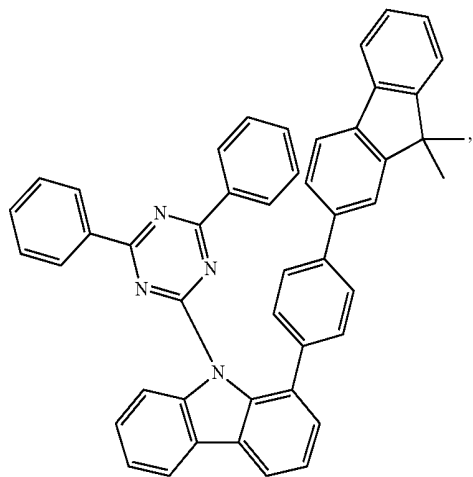

274  
-continued

Compound H15

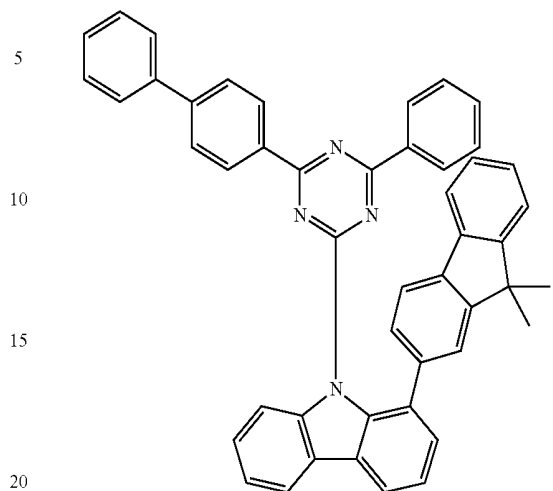

25

Compound H16

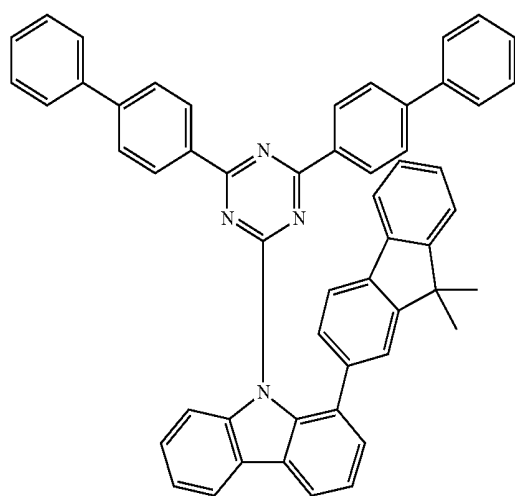
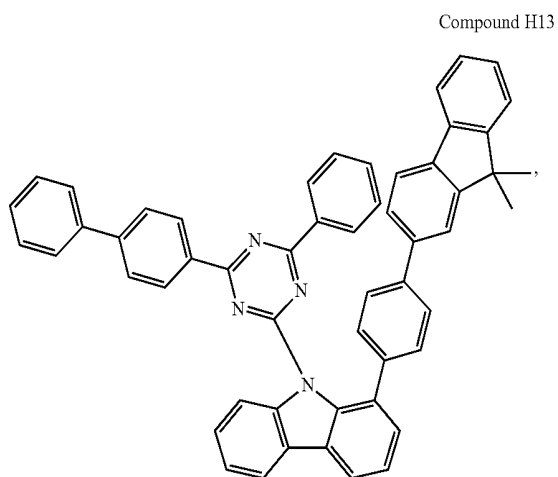

50

Compound H14

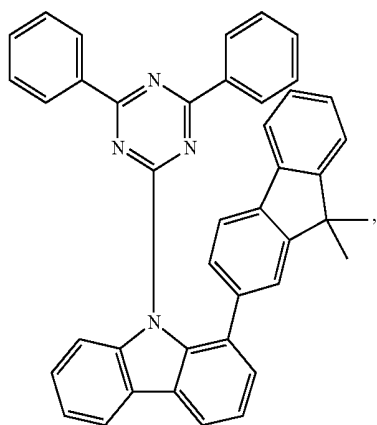

Compound H17

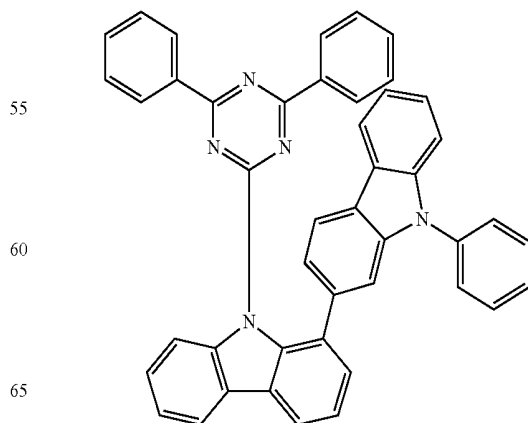

**275**  
-continued

**276**  
-continued

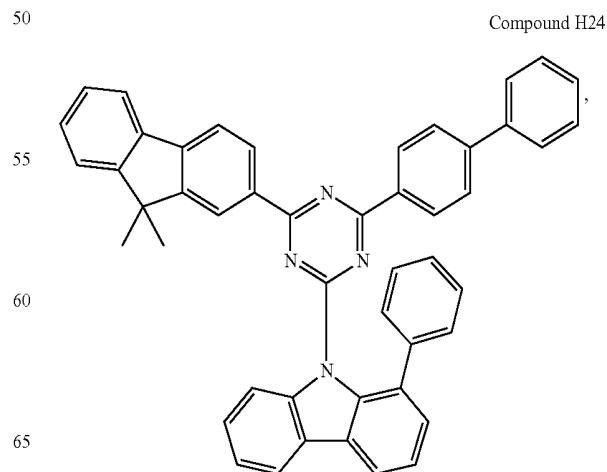
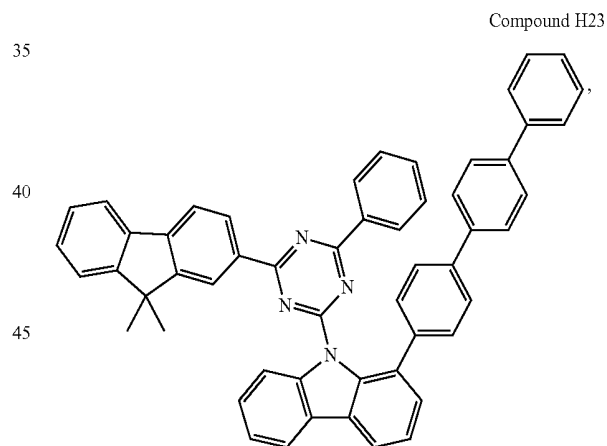
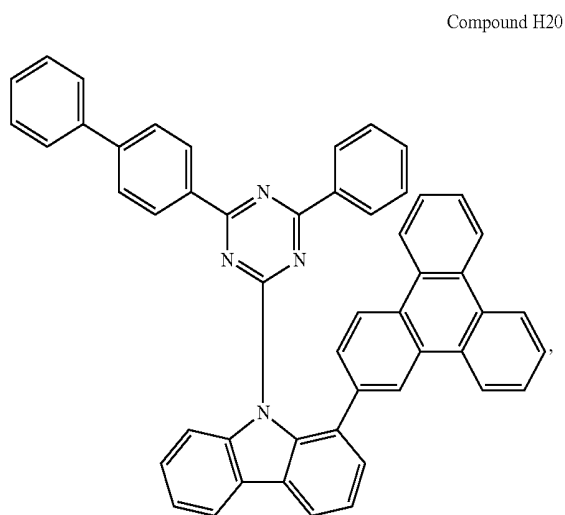
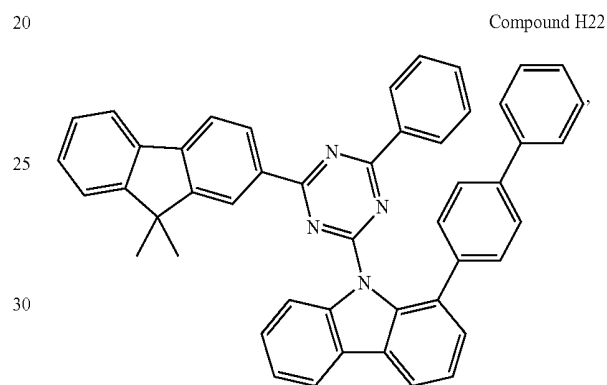
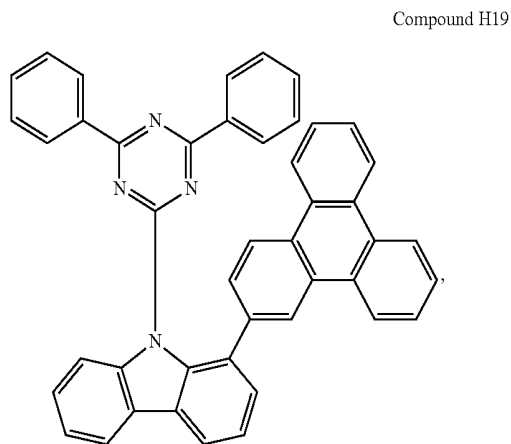
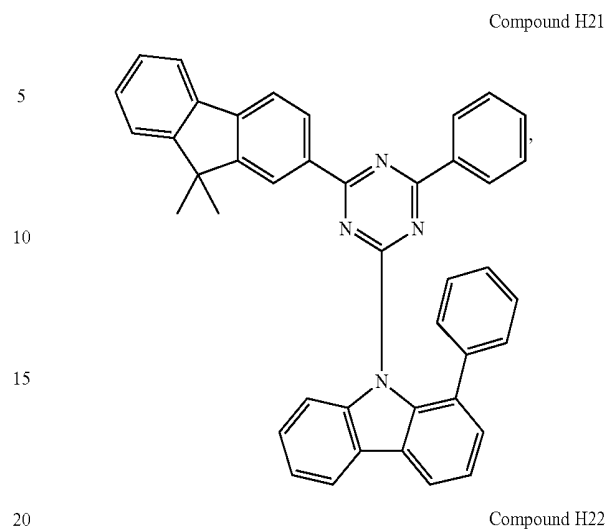
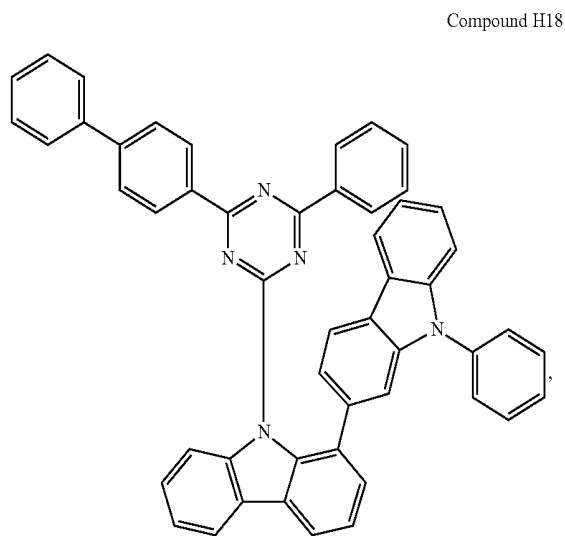

277  
-continued

278  
-continued

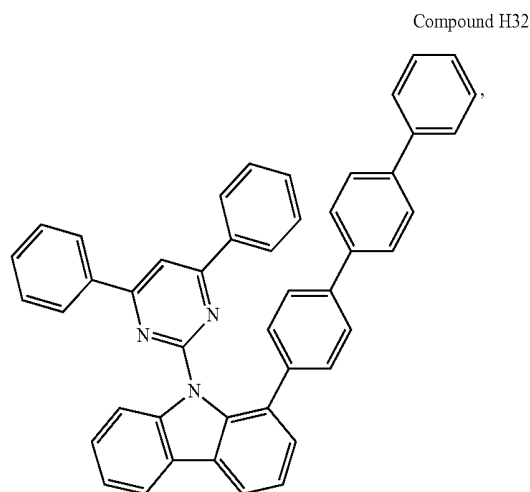
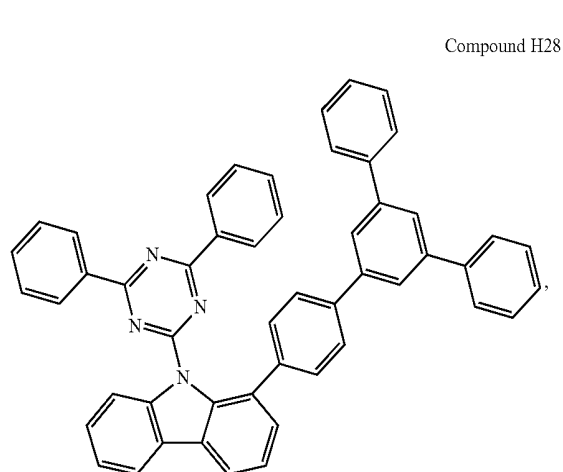
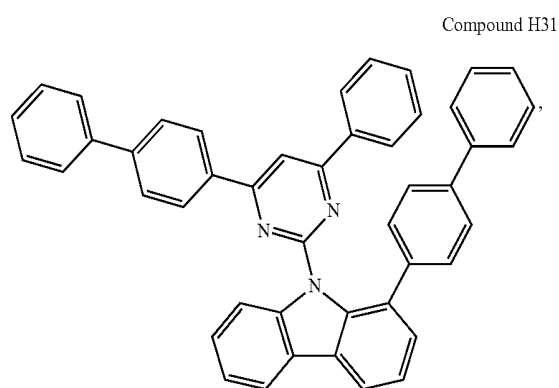
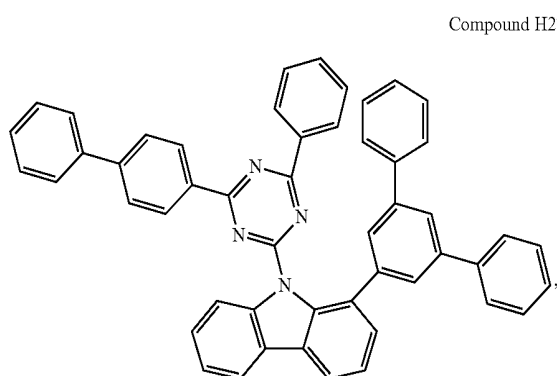
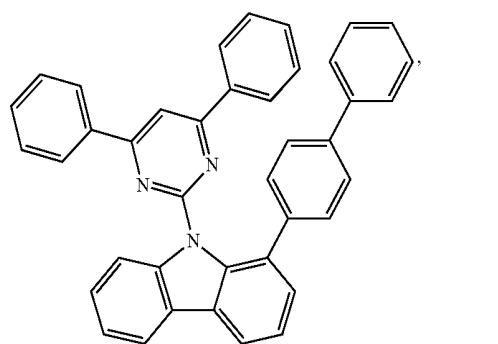
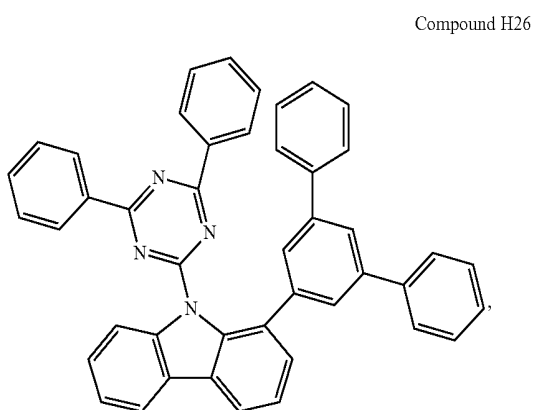
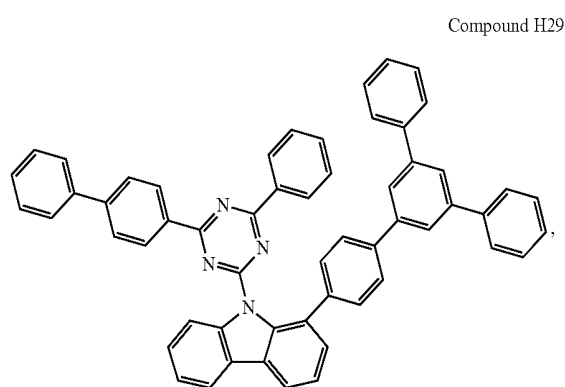
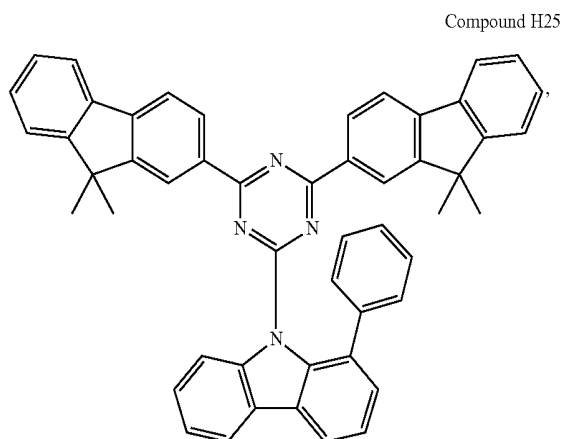

**279**  
-continued

Compound H33

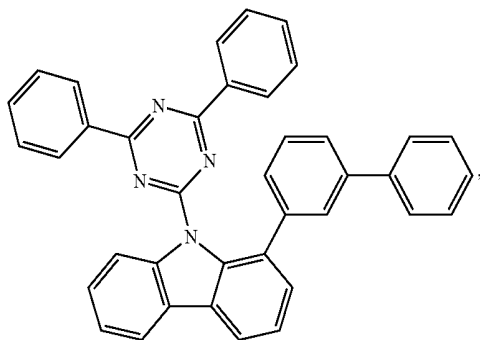

Compound H34

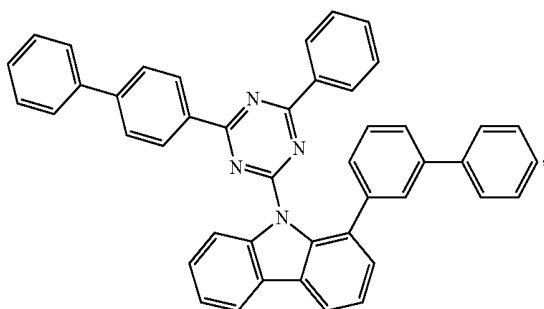

Compound H35

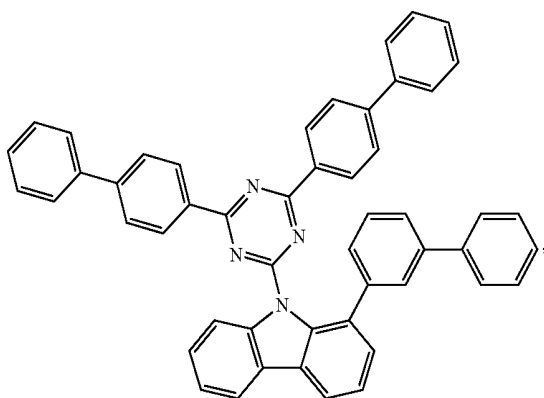

Compound H36

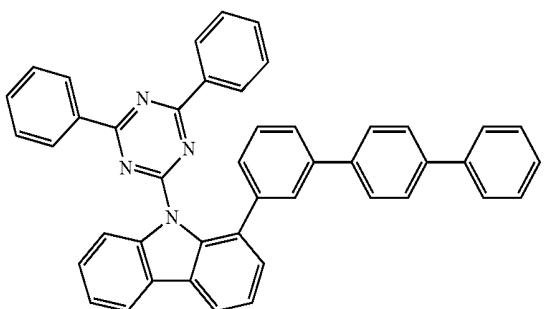

Compound H37

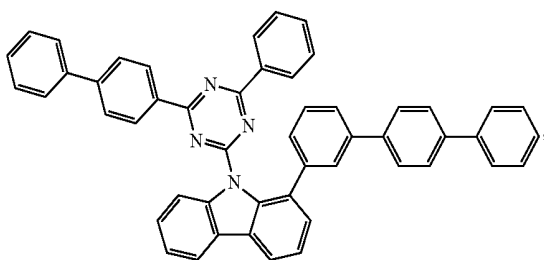

**280**  
-continued

Compound H38

5

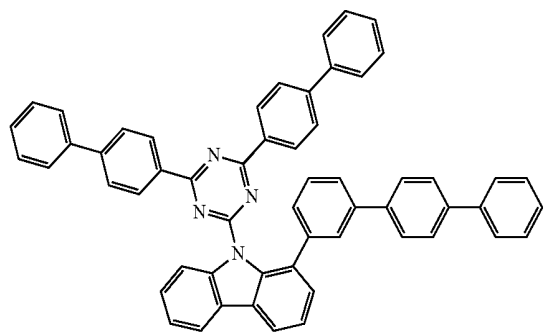

15

20

25

30

35

40

45

50

55

60

65

Compound H39

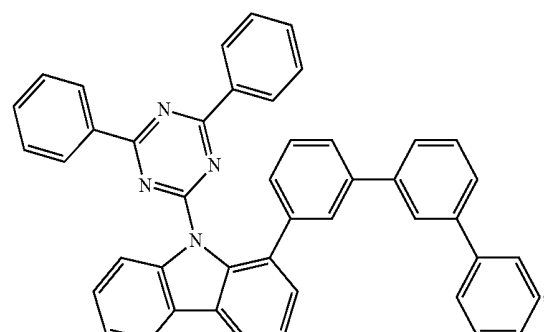

Compound H40

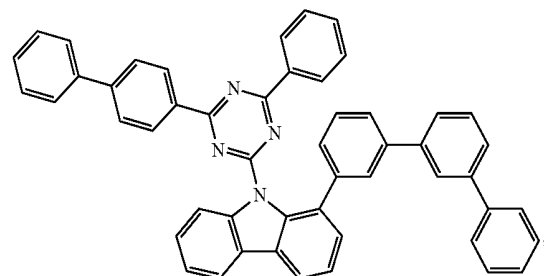

Compound H41

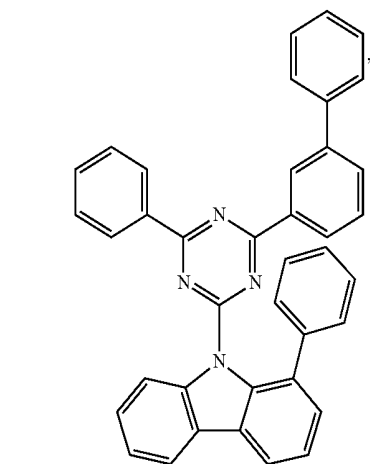

**281**  
-continued

Compound H42

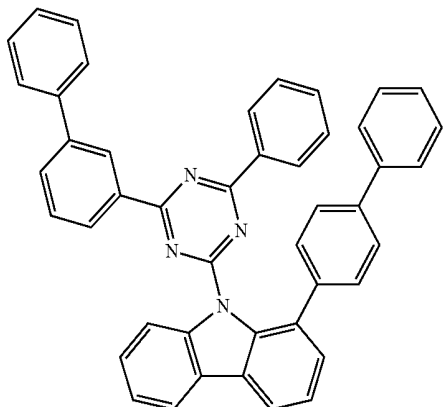

5

**282**  
-continued

Compound H45

10

15

20

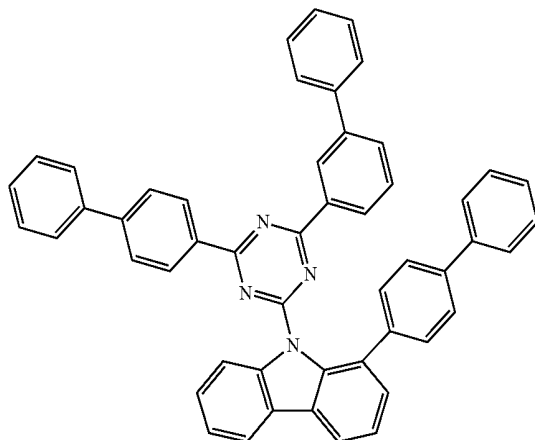

25

Compound H46

30

35

40

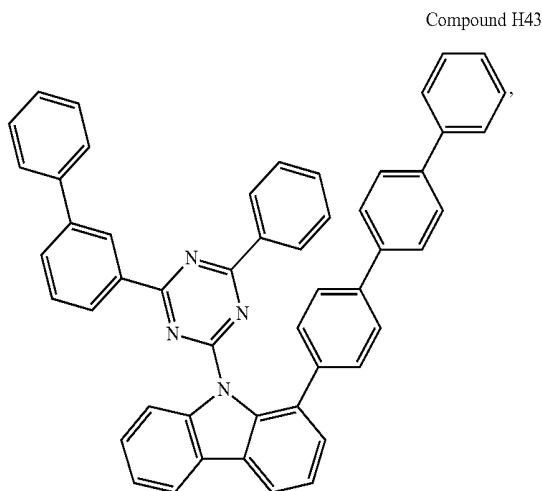

Compound H43

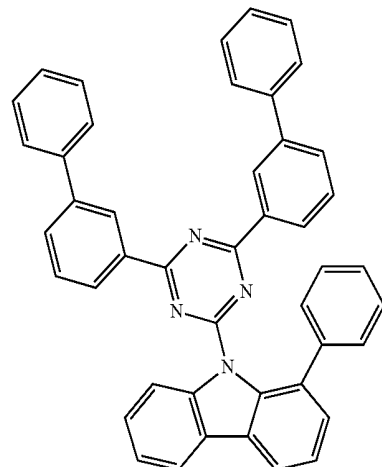

45

Compound H47

50

55

60

65

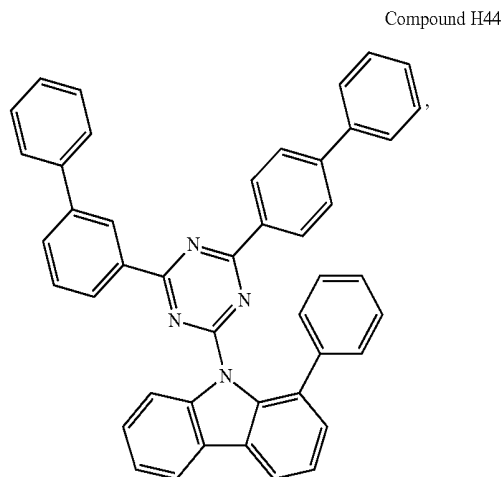

Compound H44

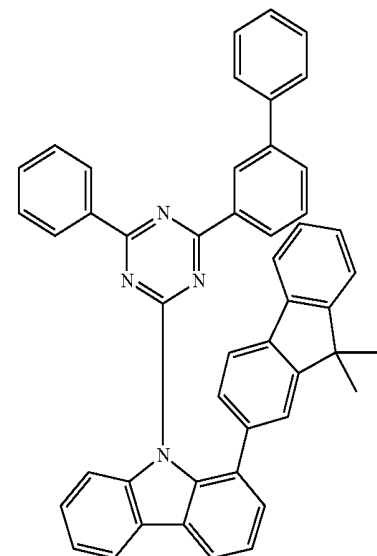

**283**  
-continued

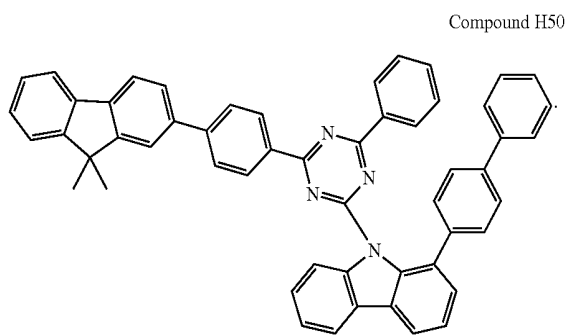
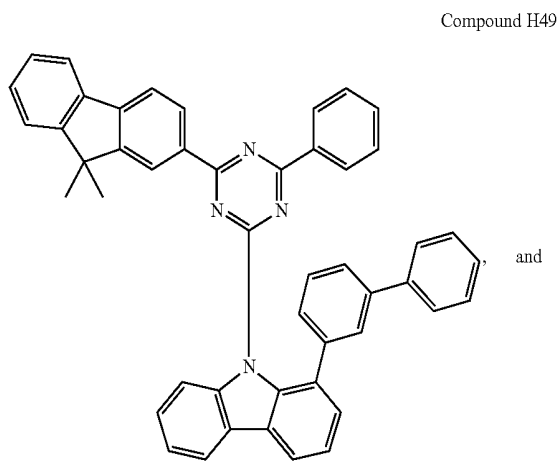
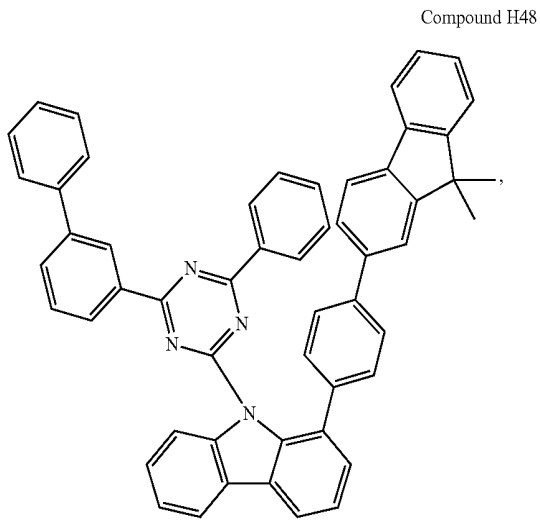

22. The composition of claim 1, wherein the first compound is selected from the group consisting of:

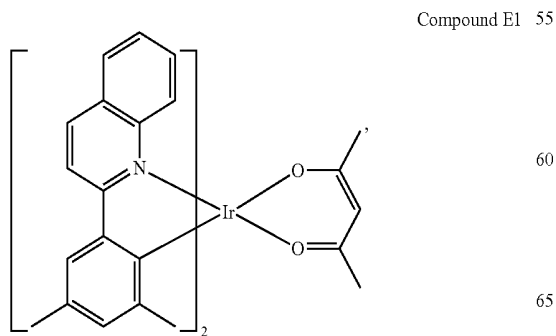

**284**  
-continued

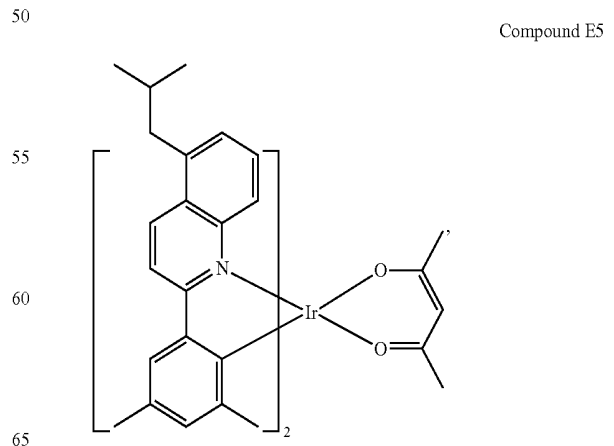
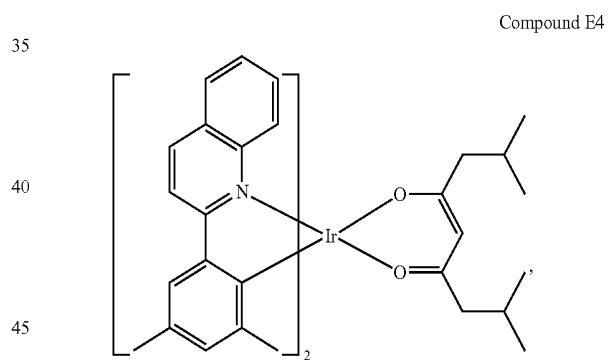
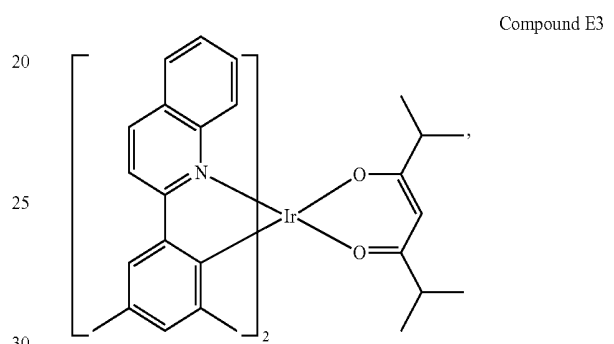
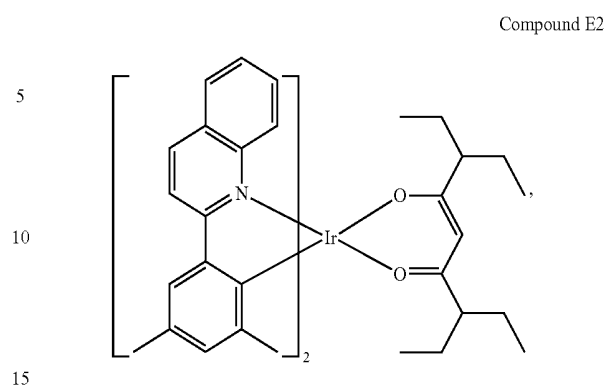

**285**  
-continued

**286**  
-continued

Compound E6

Compound E10

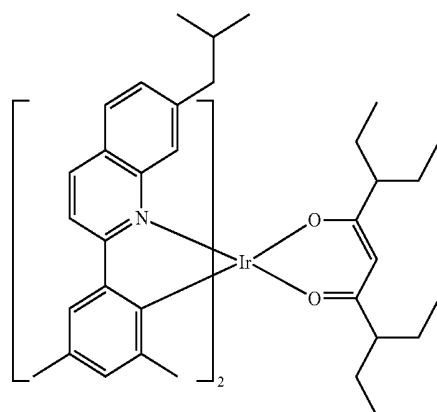
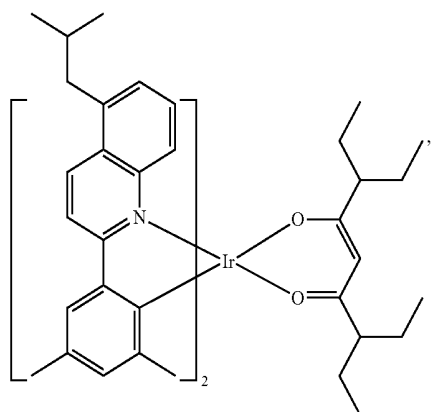

Compound E7

Compound E11

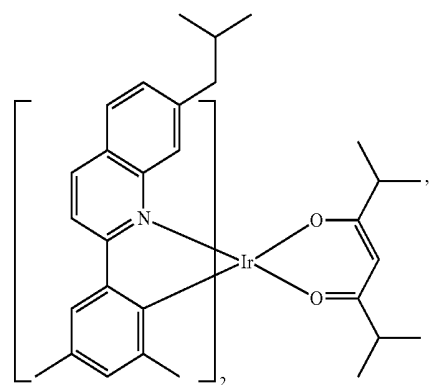
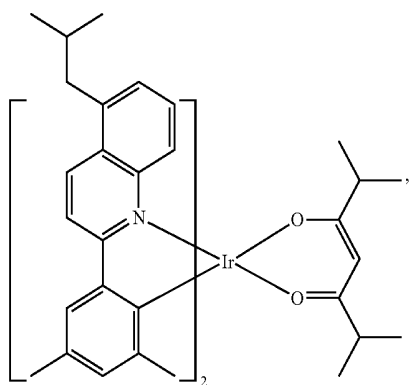

Compound E8

Compound E12

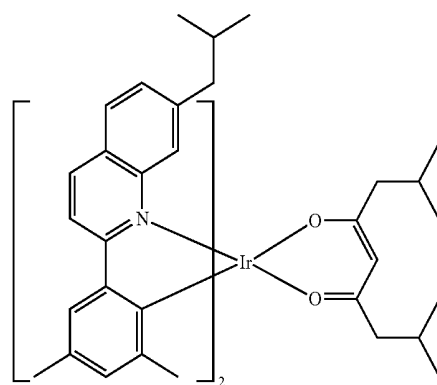
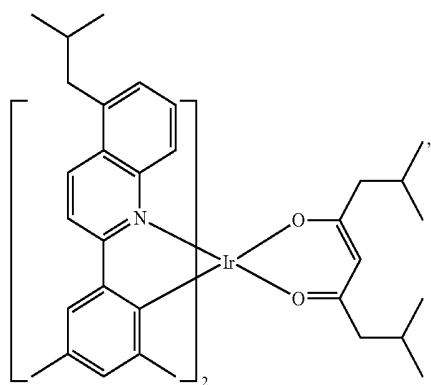

Compound E9

Compound E13

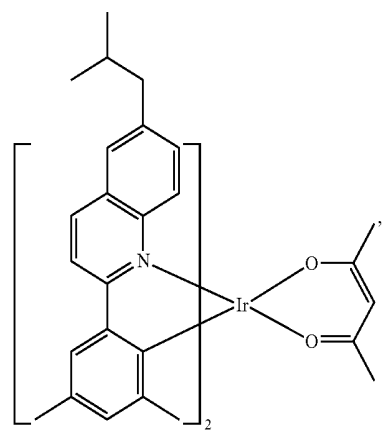
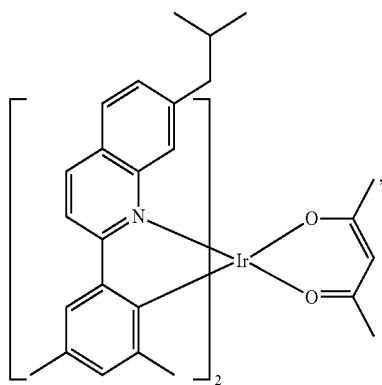

**287**  
-continued

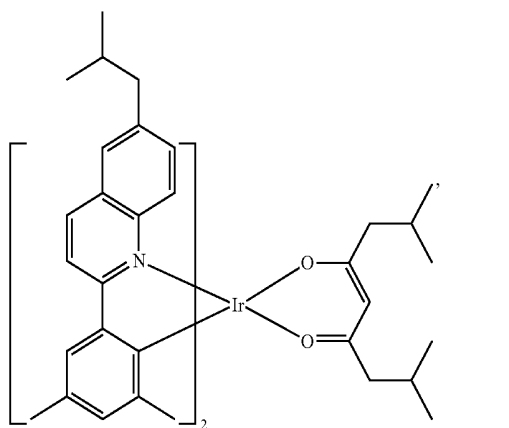
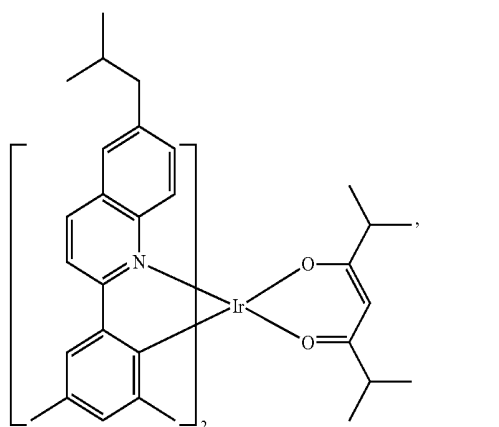
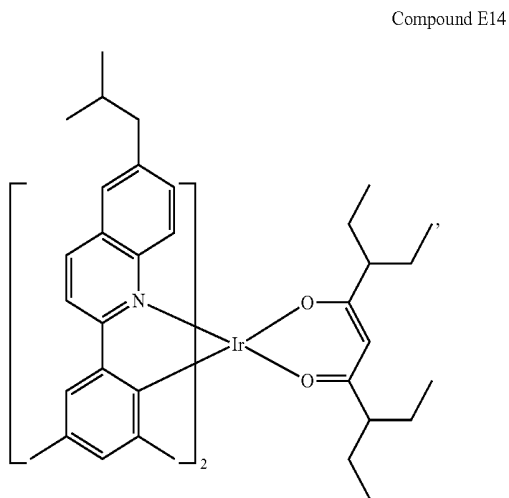

**288**  
-continued

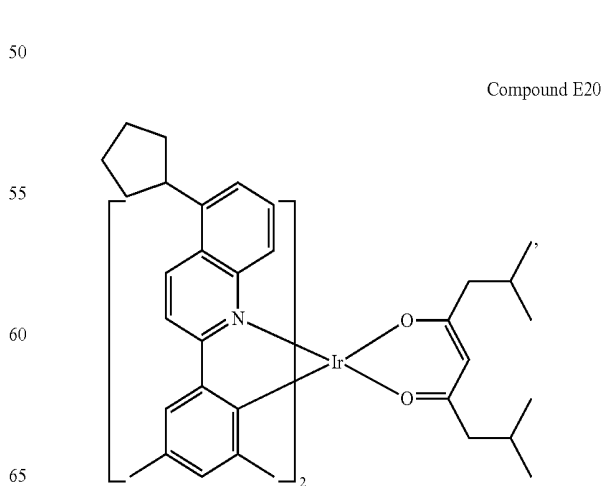
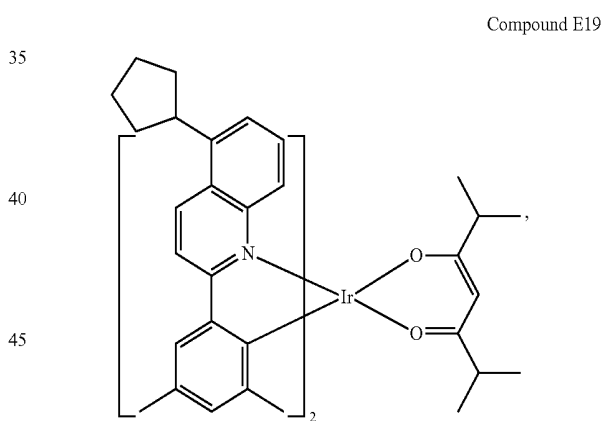
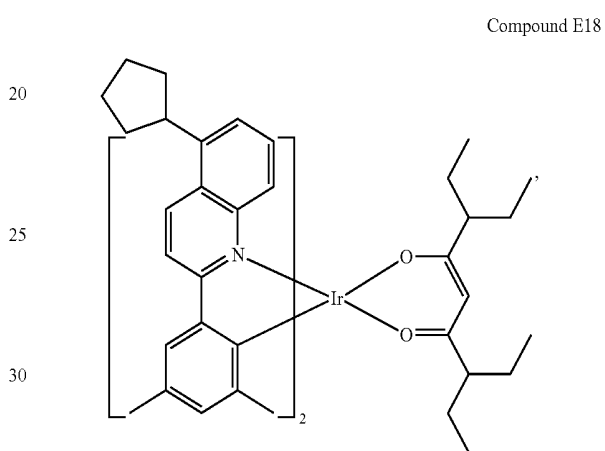
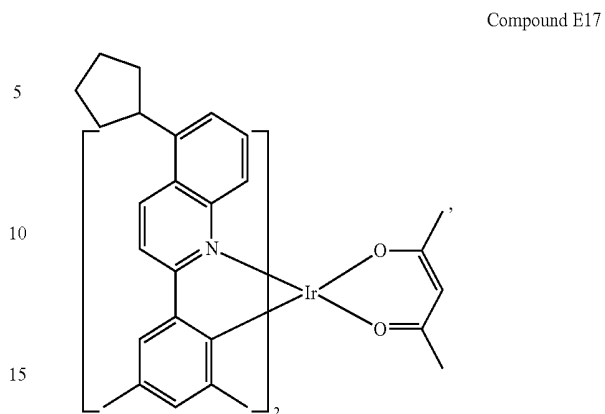

289  
-continued

290  
-continued

Compound E21

Compound E25

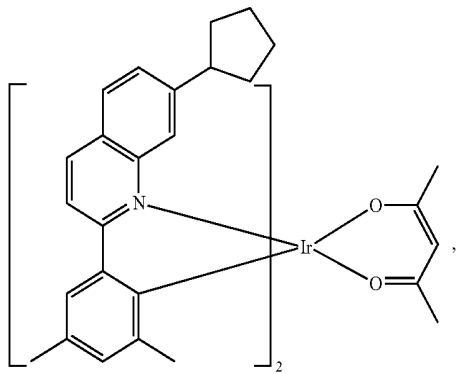

5

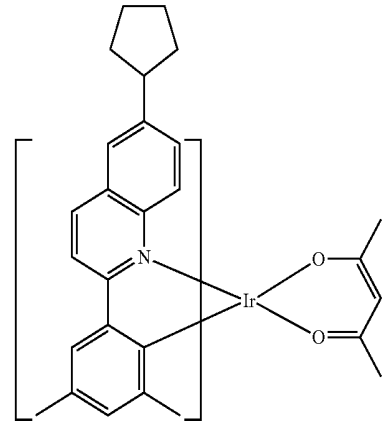

10

15

Compound E22

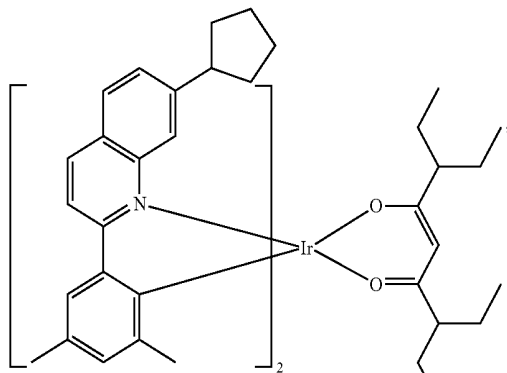

20

25

Compound E26

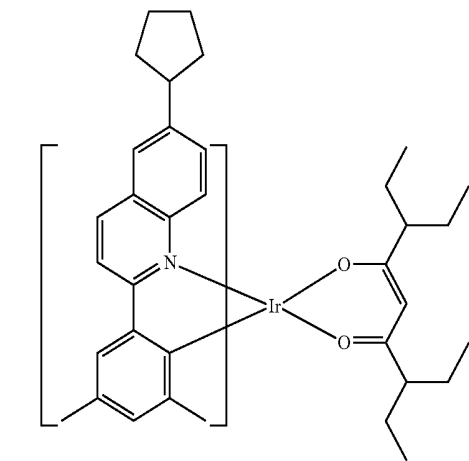

30

35

40

Compound E23

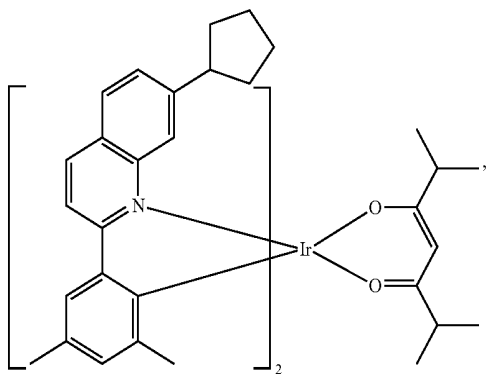

45

50

Compound E27

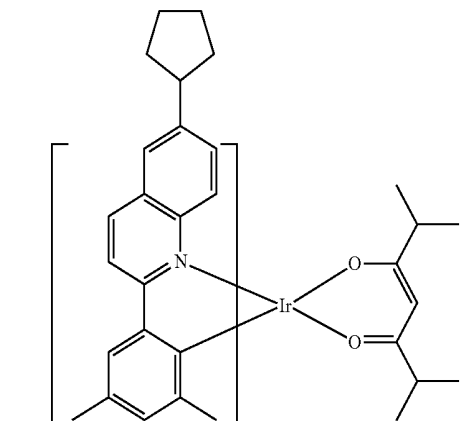

55

60

65

Compound E24

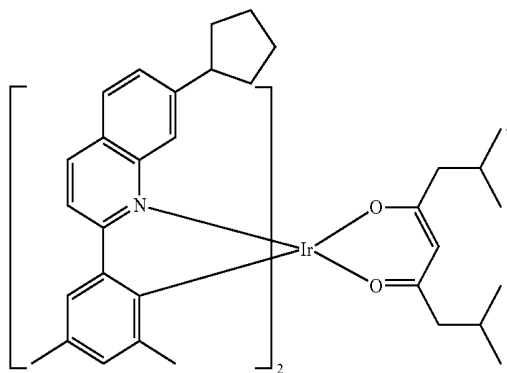

**291**  
-continued

**292**  
-continued

Compound E28

Compound E32

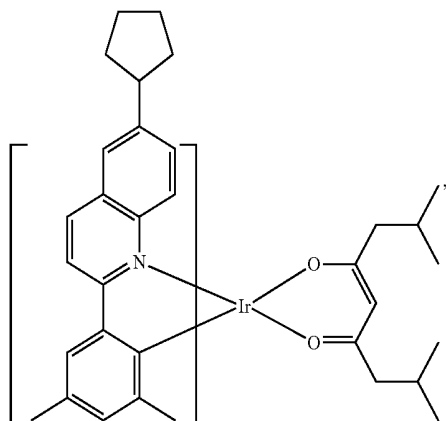

5

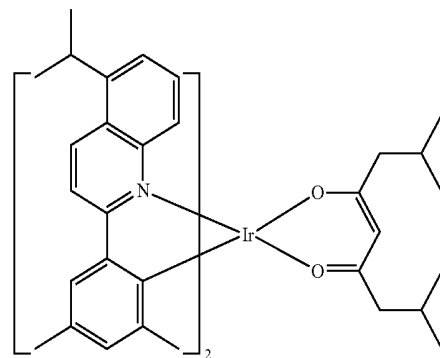

10

15

Compound E33

Compound E29

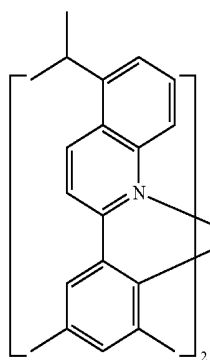

20

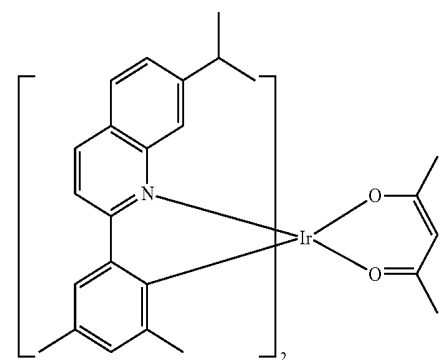

25

30

Compound E30

Compound E34

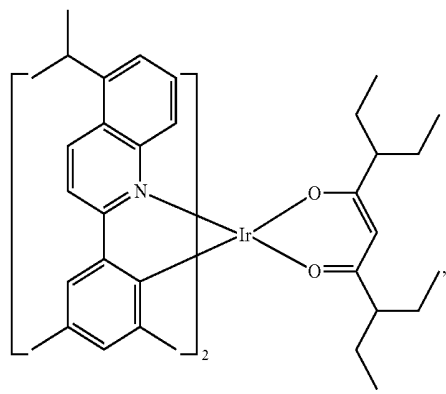

35

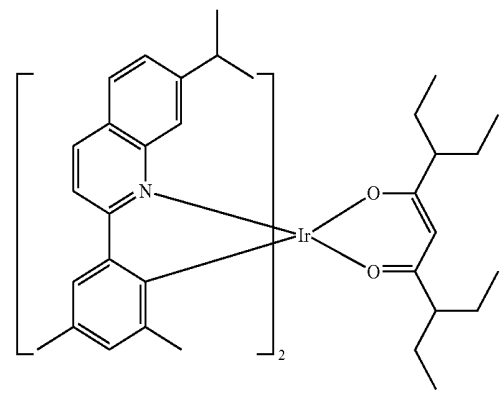

40

45

50

Compound E31

Compound E35

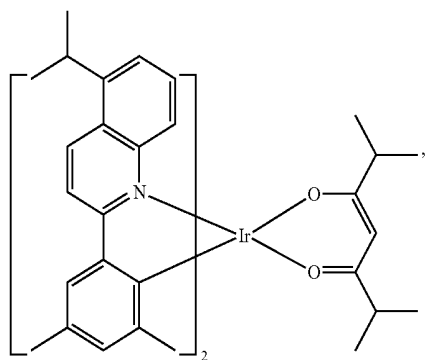

55

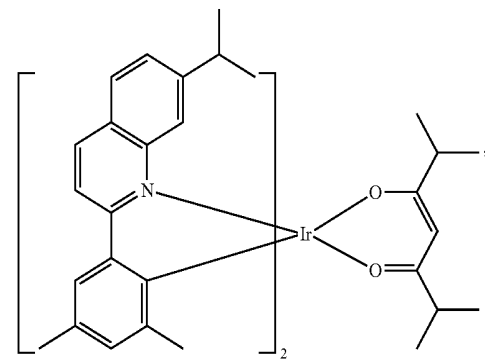

60

65

293

-continued

Compound E36

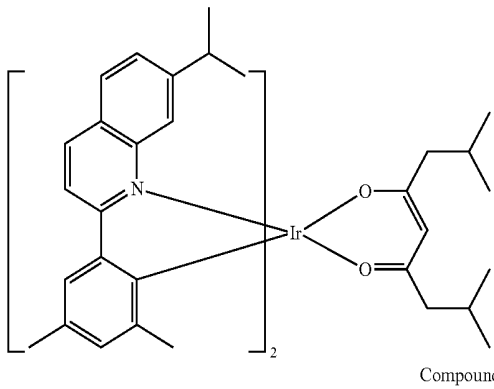

Compound E37

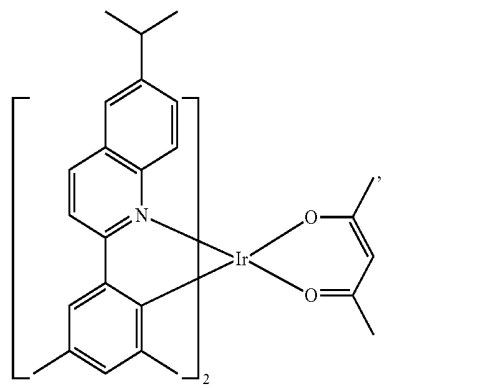

Compound E38

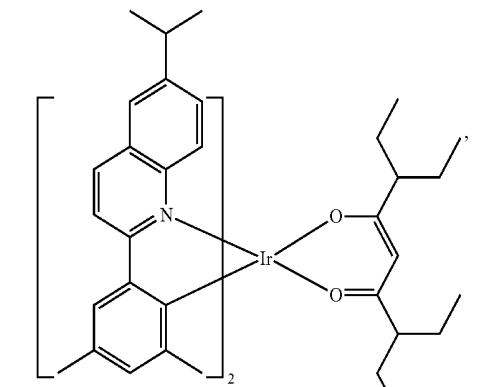

294

-continued

Compound E39

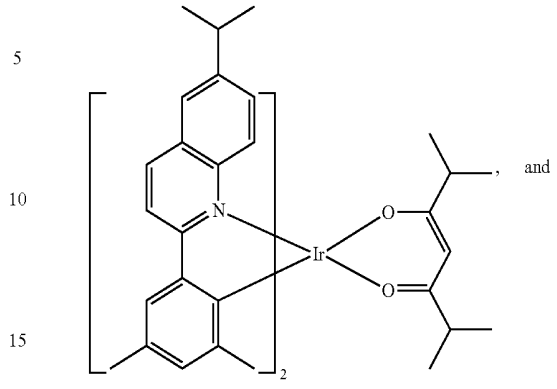

20

Compound E40

25

30

35

40

45

23. The composition of claim 1, wherein the mixture of the first compound and the second compound is selected from the group consisting of: (Compound E5

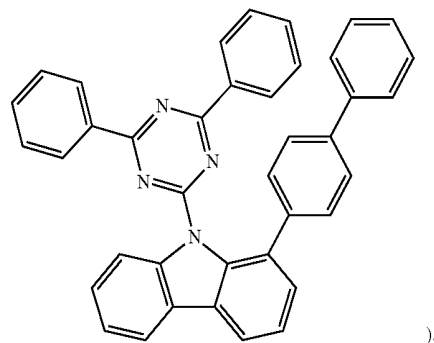
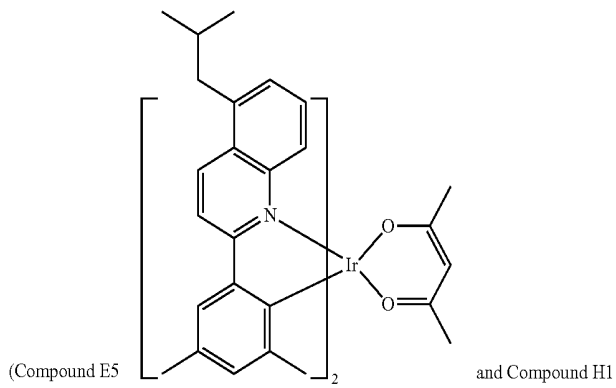

295

296

-continued

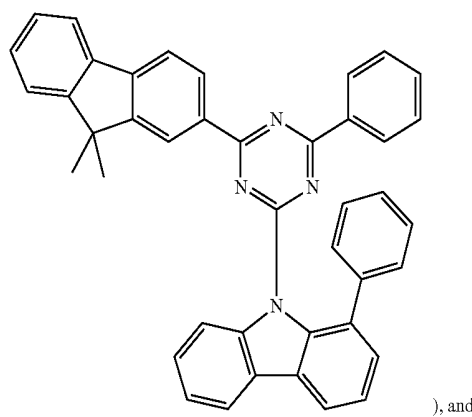
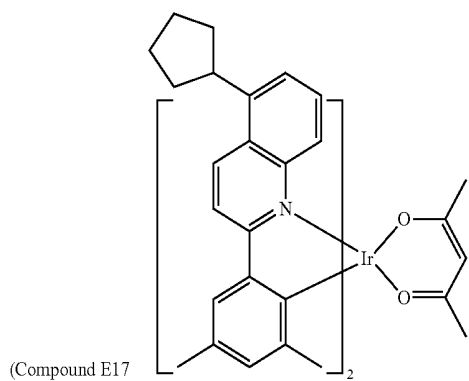
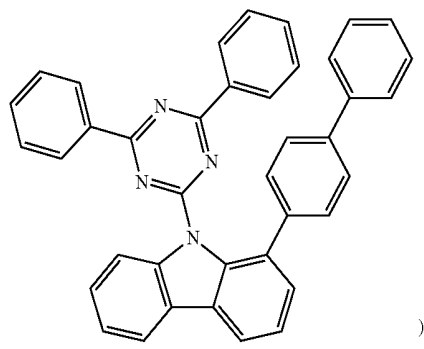
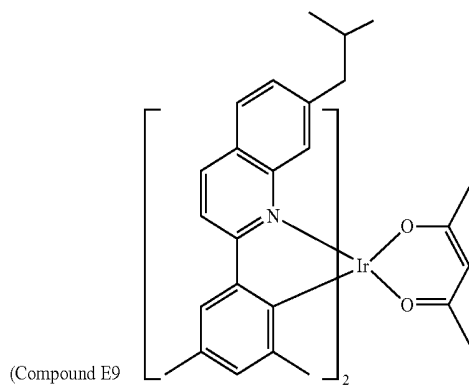
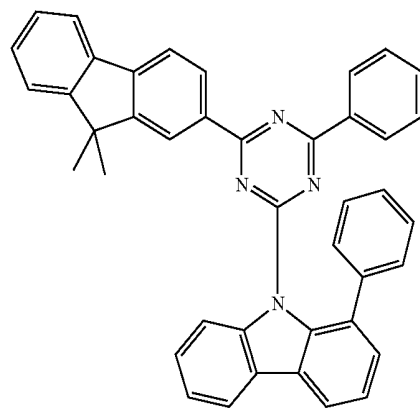
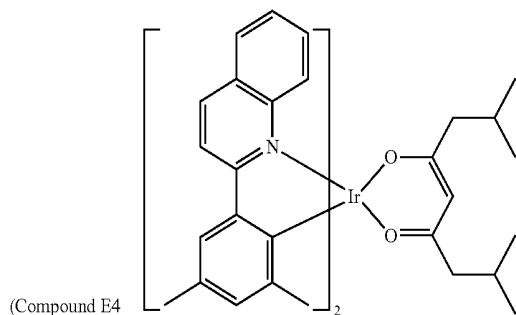
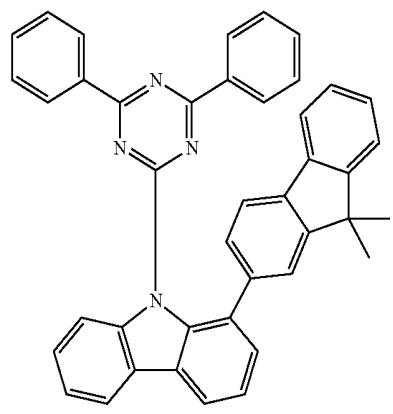
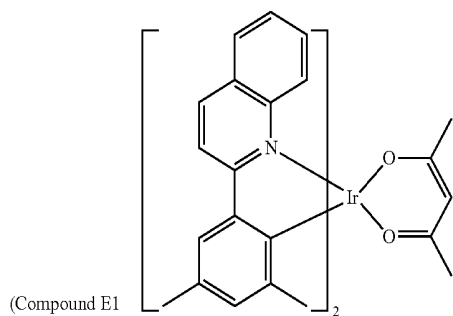

297

298

-continued

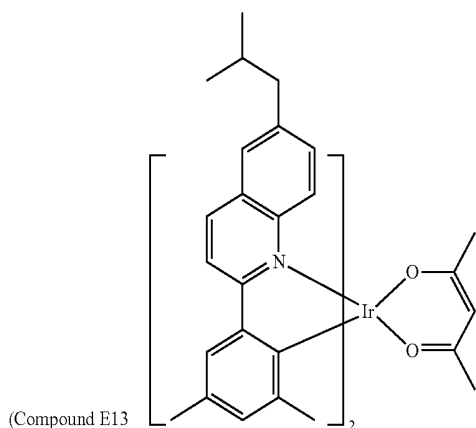

(Compound E13

and Compound H33

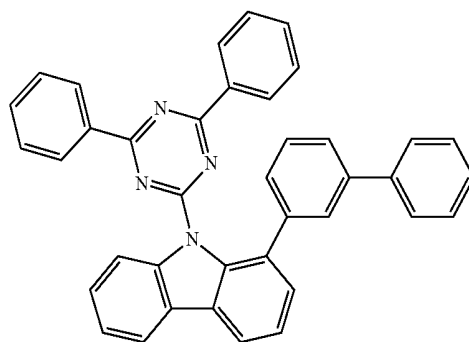

).

24. The composition of claim 1, wherein the mixture of the first compound and the second compound is

20

wherein the second compound has evaporation temperature of T2 150 to 350° C., wherein the evaporation temperature of a compound is measured in a vacuum deposition tool at a constant pressure, between  $1 \times 10^{-7}$  Torr to  $1 \times 10^{-8}$  Torr, at a 2 Å/sec deposition rate on a surface positioned at a set distance away from the evaporating compound;

25

wherein the absolute value of T1-T2 is less than 20° C.; wherein the first compound has a concentration C1 in said mixture, and a concentration C2 in a film formed by evaporating the mixture in a vacuum deposition tool at a constant pressure between  $1 \times 10^{-6}$  Torr to  $1 \times 10^{-9}$  Torr, at a 2 Å/sec deposition rate on a surface positioned at a predefined distance away from the mixture being evaporated; and

30

wherein absolute value of  $(C1-C2)/C1$  is less than 5%; wherein the first compound has a structure according to Formula I:

35

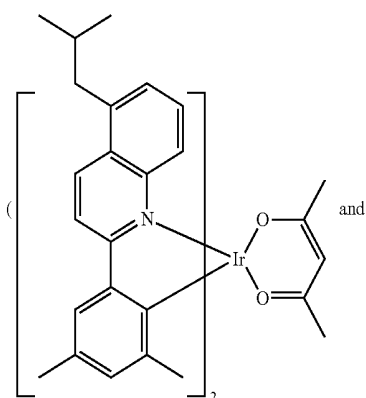

Compound E5

Compound H1

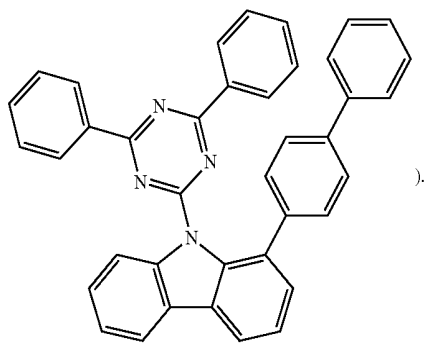

40

Formula I

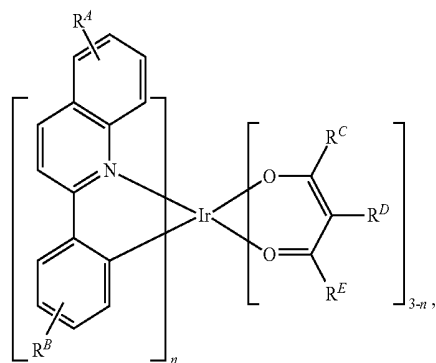

45

50

25. A first device comprising a first organic light emitting device, the first organic light emitting device comprising:

an anode;

a cathode; and

an organic layer, disposed between the anode and the cathode, comprising a first composition comprising a mixture of a first compound and a second compound, wherein the first compound has different chemical structure than the second compound;

55

wherein  $R^A$  represents mono, di, tri, tetra, penta, hexa substitutions, or no substitution;

$R^B$  represents mono, di, tri, tetra substitutions, or no substitution;

60

$R^A$ ,  $R^B$ ,  $R^C$ ,  $R^D$ , and  $R^E$  are each independently selected from the group consisting of hydrogen, deuterium, halogen, alkyl, cycloalkyl, heteroalkyl, arylalkyl, alkoxy, aryloxy, amino, cyclic amino, silyl, alkenyl, cycloalkenyl, heteroalkenyl, alkynyl, aryl, heteroaryl, acyl, carbonyl, carboxylic acid, ether, ester, nitrile, isonitrile, sulfanyl, sulfinyl, sulfonyl, phosphino, and combinations thereof;

65

wherein the first compound is capable of functioning as a phosphorescent emitter in an organic light emitting device at room temperature;

wherein the first compound has evaporation temperature of T1 150 to 350° C.;

299

wherein n is 1 or 2;  
wherein the second compound has a structure according to Formula II:

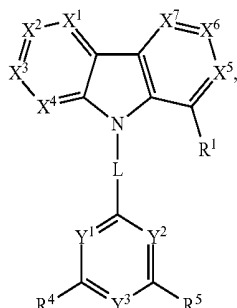

wherein X<sup>1</sup>, X<sup>2</sup>, X<sup>3</sup>, X<sup>4</sup>, X<sup>5</sup>, X<sup>6</sup>, X<sup>7</sup>, Y<sup>1</sup>, Y<sup>2</sup>, and Y<sup>3</sup> are each independently selected from the group consisting of CR and N;

wherein at least two of Y<sup>1</sup>, Y<sup>2</sup>, and Y<sup>3</sup> are N; and

wherein R<sup>1</sup>, R<sup>4</sup> and R<sup>5</sup> are independently selected from group consisting of non-fused aryl, non-fused heteroaryl, and combinations thereof;

wherein L is selected from the group consisting of a direct bond, non-fused aryl, non-fused heteroaryl, and combinations thereof; and

wherein each R is independently selected from the group consisting of hydrogen, deuterium, non-fused aryl, non-fused heteroaryl and combinations thereof.

26. A method for fabricating an organic light emitting device comprising a first electrode, a second electrode, and a first organic layer disposed between the first electrode and the second electrode, wherein the first organic layer comprises a first composition comprising a mixture of a first compound and a second compound, the method comprising:

providing a substrate having the first electrode disposed thereon;

depositing the first composition over the first electrode; and

depositing the second electrode over the first organic layer, wherein the first compound has different chemical structure than the second compound;

wherein the first compound is capable of functioning as a phosphorescent emitter in an organic light emitting device at room temperature;

wherein the first compound has an evaporation temperature T<sub>1</sub> of 150 to 350° C.;

wherein the second compound has an evaporation temperature T<sub>2</sub> of 150 to 350° C., wherein the evaporation temperature of a compound is measured in a vacuum deposition tool at a constant pressure, between 1×10<sup>-7</sup> Torr to 1×10<sup>-8</sup> Torr, at a 2 Å/sec deposition rate on a surface positioned at a set distance away from the evaporating compound;

wherein absolute value of T<sub>1</sub>-T<sub>2</sub> is less than 20° C.;

wherein the first compound has a concentration C<sub>1</sub> in said mixture, and a concentration C<sub>2</sub> in a film formed by evaporating the mixture in a vacuum deposition tool at a constant pressure between 1×10<sup>-6</sup> Torr to 1×10<sup>-9</sup> Torr, at a 2 Å/sec deposition rate on a surface positioned at a predefined distance away from the material; and

wherein absolute value of (C<sub>1</sub>-C<sub>2</sub>)/C<sub>1</sub> is less than 5%;

300

wherein the first compound has a structure according to Formula I:

5

Formula I

Formula II

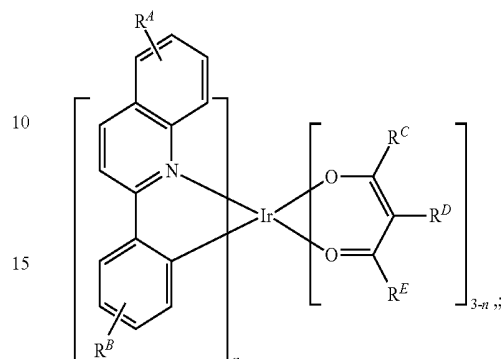

wherein

R<sup>4</sup> represents mono, di, tri, tetra, penta, hexa substitutions, or no substitution;

R<sup>5</sup> represents mono, di, tri, tetra substitutions, or no substitution;

R<sup>6</sup>, R<sup>7</sup>, R<sup>8</sup>, R<sup>9</sup>, and R<sup>10</sup> are each independently selected from the group consisting of hydrogen, deuterium, halogen, alkyl, cycloalkyl, heteroalkyl, arylalkyl, alkoxy, aryloxy, amino, cyclic amino, silyl, alkenyl, cycloalkenyl, heteroalkenyl, alkynyl, aryl, heteroaryl, acyl, carbonyl, carboxylic acid, ether, ester, nitrile, isonitrile, sulfanyl, sulfinyl, sulfonyl, phosphino, and combinations thereof;

wherein n is 1 or 2;

wherein the second compound has a structure according to Formula II:

20

25

30

35

40

45

50

55

60

65

70

75

80

85

90

95

100

105

110

115

120

125

130

135

140

145

150

155

160

165

170

175

180

185

190

195

200

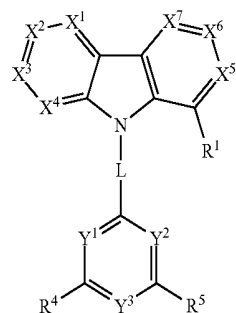

Formula II

wherein X<sup>1</sup>, X<sup>2</sup>, X<sup>3</sup>, X<sup>4</sup>, X<sup>5</sup>, X<sup>6</sup>, X<sup>7</sup>, Y<sup>1</sup>, Y<sup>2</sup>, and Y<sup>3</sup> are each independently selected from the group consisting of CR and N;

wherein at least two of Y<sup>1</sup>, Y<sup>2</sup>, and Y<sup>3</sup> are N; and

wherein R<sup>1</sup>, R<sup>4</sup> and R<sup>5</sup> are independently selected from group consisting of non-fused aryl, non-fused heteroaryl, and combinations thereof;

wherein L is selected from the group consisting of a direct bond, non-fused aryl, non-fused heteroaryl, and combinations thereof; and

wherein each R is independently selected from the group consisting of hydrogen, deuterium, non-fused aryl, non-fused heteroaryl and combinations thereof.

\* \* \* \* \*

专利名称(译)	有机电致发光材料和器件		
公开(公告)号	<a href="#">US10074806</a>	公开(公告)日	2018-09-11
申请号	US14/253505	申请日	2014-04-15
[标]申请(专利权)人(译)	环球展览公司		
申请(专利权)人(译)	通用显示器公司		
当前申请(专利权)人(译)	通用显示器公司		
[标]发明人	ADAMOVICH VADIM YAMAMOTO HITOSHI WANG TING CHIH WEAVER MICHAEL S XIA CHUANJUN ALLEYNE BERT BOUDREAULT PIERRE LUC T DYATKIN ALEXEY BORISOVICH JOSEPH SCOTT		
发明人	ADAMOVICH, VADIM YAMAMOTO, HITOSHI WANG, TING-CHIH WEAVER, MICHAEL S. XIA, CHUANJUN ALLEYNE, BERT BOUDREAULT, PIERRE-LUC T. DYATKIN, ALEXEY BORISOVICH JOSEPH, SCOTT		
IPC分类号	H01L51/00 H01L51/50 H01L51/56 C07D403/10 C07D471/04 C07D215/06 C07D401/04 C07D403/14 C07D487/04 C07D491/048 C07D495/04 C07D213/06 C07D213/22 C07D213/26 C07F15/00 C07D403 /04		
CPC分类号	H01L51/0054 H01L51/56 C07D213/22 C07D213/26 C07D215/06 C07D401/04 C07D403/04 C07D403 /10 C07D403/14 C07D471/04 C07D487/04 C07D491/048 C07D495/04 C07F15/0033 H01L51/0052 H01L51/0067 H01L51/0071 H01L51/0072 H01L51/0085 H01L51/5012 H01L51/5016 C07D213/06		
代理机构(译)	DUANE MORRIS LLP		
优先权	61/940603 2014-02-17 US 61/920544 2013-12-24 US 61/894160 2013-10-22 US 61/874444 2013-09-06 US 61/867858 2013-08-20 US		
其他公开文献	US20150053939A1		
外部链接	<a href="#">Espacenet</a>		

#### 摘要(译)

本发明公开了一种由具有相似热蒸发性质的两种化合物的混合物形成的组合物，其预先混合到蒸发源中，该蒸发源可用于通过真空热蒸发工艺将两种化合物共蒸发成OLED中的发光层。

